

\*



C16-EE-303

6239

BOARD DIPLOMA EXAMINATION, (C-16)

MARCH/APRIL—2021

DEEE - THIRD SEMESTER EXAMINATION

ELECTRICAL CIRCUITS

Time : 3 hours ]

[ Total Marks : 80

---

PART—A

3×10=30

- Instructions :** (1) Answer **all** questions.  
(2) Each question carries **three** marks.  
(3) Answers should be brief and straight to the point and shall not exceed five simple sentences.

1. List the methods of measurement of medium resistance.
2. State Kirchhoff's Laws.
3. Three resistances of  $4\ \Omega$ ,  $6\ \Omega$  and  $8\ \Omega$  are connected in delta, find the equivalent star connected resistances.
4. State maximum power transfer theorem.
5. Derive the relation between poles, speed and frequency.
6. Show that the average power consumed in a pure inductor is zero.
7. Define Q-factor of series resonant circuit.
8. Compare the series and parallel resonance circuits in three aspects.
9. Define the poly-phase and draw 3-phase waveforms.
10. State the relation between line and phase values of delta connected network.

\*

## PART—B

**Instructions :** (1) Answer *any five* questions.

(2) Each question carries **ten** marks.

(3) Answers should be comprehensive and criterion for valuation is the content but not the length of the answer.

11. Explain the construction and working of megger with a neat diagram. 10

12. For the circuit shown in Fig., find the loop currents by using loop analysis method. 10

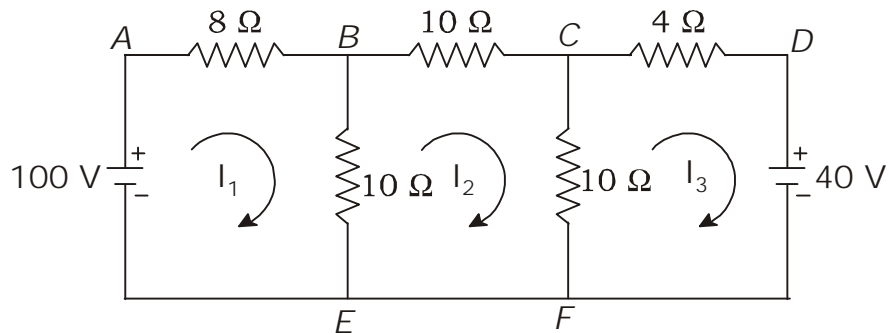

13. (a) State and explain superposition theorem. 5

(b) A balanced 3-phase star connected load of 80 kW at a power factor of 0.8 lagging is connected across a 400 V, 50 Hz supply. Find the circuit constants of load per phase. 5

\*

14. (a) An alternating current '*i*' is given by  $i = 141.4 \sin 314 t$ . Find (i) maximum value, (ii) frequency, (iii) time period and (iv) instantaneous value when *t* is 3 ms. 6

(b) Convert the following polar to rectangular or rectangular to polar :

(i)  $200 \angle 30^\circ$  (ii)  $16 + j12$  4

\*

15. A  $4\ \Omega$  resistance connected in series to a 10 mH inductance across a 100 V, 50 Hz supply. Find (i) impedance (ii) current (iii) voltage drop across resistance and inductance, (iv) power factor (v) phase angle between V and I, (vi) total power supplied. 10
16. A coil of resistance  $40\ \Omega$  and inductance 0.75 H forms part of series circuit for which the resonant frequency is 55 Hz. If the supply is 250 V, 50 Hz, find (i) line current, (ii) power factor of total circuit and coil, (iii) voltage across the coil. 10
17. Two impedances  $Z_1 = (5 + j 10)\ \Omega$  and  $Z_2 = (10 - j 15)\ \Omega$  are connected in parallel. If the total current supplied to the combination is 20 A, find (i) voltage applied, (ii) power factor and (iii) power dissipated in each branch. 10
18. (a) A balanced delta connected load  $(10 + j 10)\ \Omega$  per phase is connected to a 3-phase, 400 V, 50 Hz supply. Calculate the line current, power factor and power drawn. 5
- (b) Derive the formula for measurement of 3-phase power by using two watt-meters. 5

★ ★ ★

\*