



**c16-c-306**

**6227**

**BOARD DIPLOMA EXAMINATION, (C-16)**

**AUGUST/SEPTEMBER—2021**

**DCE - THIRD SEMESTER EXAMINATION**

**CIVIL ENGINEERING DRAWING – I**

*Time : 3 hours ]*

*[ Total Marks : 60*

---

**PART—A**

4×5=20

- Instructions :**
- (1) Answer **all** questions.
  - (2) Each question carries **four** marks.
  - (3) Any missing data may be assumed suitably.

**1.** Draw the conventional signs for the following represented in sectional elevation :

- (a) Wood
- (b) Glass
- (c) Main switch
- (d) European type water closet

**2.** Draw the elevation of a door shutter and label the parts.

**3.** State the minimum area and minimum width for the following rooms as per building bye-laws :

- (a) Bedroom
- (b) Kitchen-cum-dining room
- (c) Combined bathroom and water closet
- (d) Storeroom

4. Draw the working drawing for the purpose of marking the width of foundation of a single-room building of size 4 m × 6 m with superstructure wall of 200 mm thick and the width of footing is 1000 mm.
5. Draw an electrical layout for one bedroom residential building showing at least four components.

### PART—B

**Instructions :** (1) Answer **all** questions.

(2) Any missing data may be assumed suitably.

6. The line diagram of a residential building is shown in the figure below. From the given specification, draw the following views to a scale of 1 : 50

(a) Fully dimensional detailed plan. 15

(b) Section along A-A 10

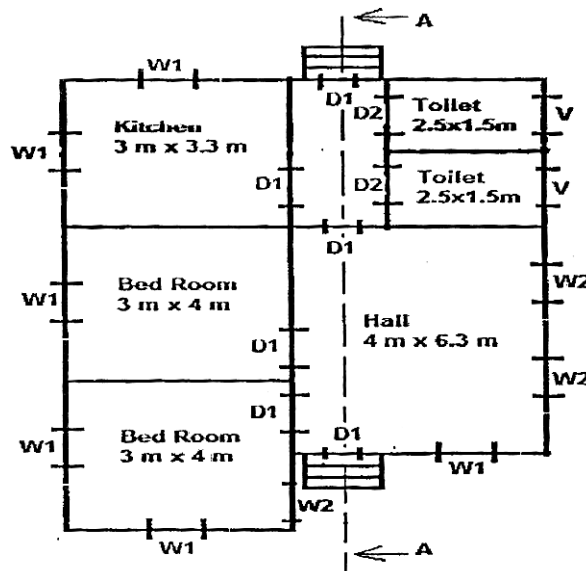

**Figure. 1**

\* *Specifications :*

- (i) All the dimensions shown in the line diagram are in mm.
- (ii) Foundations : All the main walls are taken to a depth of 1000 mm below the ground level and rest on CC bed (1 : 4 : 8) of 800 mm wide and 300 mm deep. The remaining portion consists of two footings of 500 mm and 400 mm wide and of 400 mm and 300 mm deep. The footings are of brick masonry in CM (1 : 4).
- (iii) Basement: All the walls are 300 mm wide and the height of basement is 600 mm above the ground level.
- (iv) Steps : Steps of 1200 mm wide are provided with brick masonry in CM (1 : 6) both on front and rear sides and rest on CC bed (1 : 4 : 8) of 150 mm thick and having offset on the three sides equal to 150 mm. Tread of each step is 300 mm and rise is 150 mm.
- (v) Flooring : Flooring consists of mosaic tiled flooring over 100 mm thick CC bed (1 : 4 : 8). The remaining portion of basement is filled and compacted with sand.
- (vi) Superstructure and roofing: All the walls are taken to a height of 3300 mm and 300 mm thick except the partition wall between toilets which is 100 mm thick. The roofing consists of RCC slab of 120 mm thick provided over the entire building.
- (vii) Sunshades and lintels : RCC lintels are provided on all openings like doors, windows, ventilators with 100 mm thick having a bearing of 150 mm on either side. RCC sunshades are provided over all exterior doors, windows and ventilators with 90 mm thickness at wall face and 75 mm thickness at free end. The projection of sunshades beyond the wall surface is 700 mm.
- (viii) Parapet wall : Brick masonry parapet wall is cement mortar (1 : 6) is of 100 mm thick and 700 mm height. A coping of 50 mm projection is provided at the top of the parapet wall.
- (ix) Doors, windows and ventilators : These are to be provided as per the schedule indicated.

<i>Sl. No.</i>		<i>Modular size (in mm)</i>
1	D1	1000 × 2100
2	D2	900 × 1800
3	W1	1500 × 1200
4	W2	900 × 1200
5	V	600 × 400

7. Draw the line diagram showing the functional requirements of a rural hospital of 10 beds capacity to a suitable scale.

15

★ ★ ★

\*

\*