

## **C21\_ Curriculum**

# **DIPLOMA IN EMBEDDED SYSTEMS ENGINEERING**



**OFFERED BY**

**STATE BOARD OF TECHNICAL EDUCATION & TRAINING,**

**TELANGANA: HYDERABAD**

## II SEMESTER

Sl No	Course Code	Course Name	Teaching Scheme				Credits	Examination Scheme						
			Instruction periods per week			Total Periods per semester		Continuous internal evaluation			Semester end examination			
			L	T	P			Mid Sem 1	Mid Sem 2	Internal evaluation	Max Marks	Min Marks	Total Marks	Min marks for Passing including internal
1	HU-101	Basic English	3	2	0	75	3	20	20	20	40	14	100	35
2	SC-102	Basic Engineering Mathematics	4	1	0	75	3	20	20	20	40	14	100	35
3	SC-103	Basic Physics	4	1	0	75	3	20	20	20	40	14	100	35
4	SC-104	General Engineering Chemistry	4	1	0	75	3	20	20	20	40	14	100	35
5	EC-105	Basic Electrical & Electronics Engineering	3	2	0	75	3	20	20	20	40	14	100	35
6	ME-106	Basic Engineering Drawing	1	0	2	45	1.5	20	20	20	40	20	100	50
7	ME-107	Basic AutoCAD Lab	1	0	2	45	1.5	20	20	20	40	20	100	50
8	EC-108	Basic Electrical & Electronics Engineering Lab	1	0	2	45	1.5	20	20	20	40	20	100	50
9	SC-109	Basic Science Lab	1	0	2	45	1.5	20	20	20	40	20	100	50
10	CS-110	Basic Computer Science Lab	1	0	2	45	1.5	20	20	20	40	20	100	50
11	ES-111	Skill Upgradation	0	0	8	120	2.5	0	0	Rubrics			--	-
Activities: student performance is to be assessed through Rubrics														

## HU-101 - Basic English

Course Title	Basic English	Course Code	HU-101
Semester	I	Course Group	Foundation
Teaching Scheme in Minutes (L:T)	4:1:0	Credits	3
Methodology	Communicative Language Teaching + Assignments	Total Contact Hours	75
CIE	60 Marks	SEE	40 Marks

**Prerequisites:** Basic knowledge of English Language

### COURSE CONTENTS

#### MODULE 1: VOCABULARY

**Duration: 12 Periods – ( L 8 P 4 )**

1. How to Use a Dictionary
  - a) How to locate a word
  - b) Different kinds of dictionaries
  - c) Uses of dictionaries and digital dictionaries
2. Building Vocabulary
  - a) Words from other languages – Greek, Latin, French, Sanskrit, Hindi, and Telugu.
  - b) Words from names of people (Eponyms) with focus on terms used in science and technology.
  - c) Word Forms – Focus on words from Science and Technology.
3. Words Often Confused
  - a) Homonyms, Homophones.
  - b) Heteronyms, Heterophones
  - c) Capitonyms

#### MODULE 2: READING

**Duration: 12 Periods – ( L 8 P 4 )**

1. Purpose of Reading
2. Types of Reading
3. Types of Paragraphs and Questions (F I V E )

#### MODULE 3: SPEAKING

**Duration: 12 Periods – ( L 8 P 4 )**

1. Need for English
2. Classroom English

3. Expressing Feelings
4. Expressing Likes & Dislikes
5. Making Requests
6. How to Introduce Oneself
7. Expressing obligations.

**MODULE 4: GRAMMAR I**

**Duration: 12 Periods – ( L 8 P 4 )**

1. Basic Sentence Patterns
2. Tenses
3. Voice

**MODULE 5: GRAMMAR II**

**Duration: 15 Periods – ( L 10 P 5 )**

1. Adjectives
2. Prepositions
3. Asking Questions

**MODULE 6: WRITING**

**Duration: 12 Periods – ( L 8 P 4 )**

1. Paragraph Writing – I
2. Paragraph Writing – II
3. Letter Writing – I
4. Letter Writing – II

**COURSE OUTCOMES**

<b>No.</b>	At the end of the course, the students will have the ability to:
<b>101.1</b>	Use a dictionary and acquire vocabulary for social interaction.
<b>101.2</b>	Comprehend, identify main ideas, make inferences, visualize, and answer questions. Analyze and evaluate the written material.
<b>101.3</b>	Speak and write grammatically correct sentences, communicate effectively, express their likes, dislikes, feelings, make requests, express obligations and introduce themselves.
<b>101.4</b>	Use verbs in the different tenses according to the situations. Use Voice to express an action clearly
<b>101.5</b>	Describe people and objects, ask questions, use prepositions and write grammatically correct sentences.
<b>101.6</b>	Convey ideas in the form of paragraphs and letters

**CO-PO Matrix**

CO	PO 1	PO 2	PO 3	PO 4	PO 5	PO 6	PO 7	Mapping POs
101.1	-	-	-	-	3		3	5,7
101.2	-	-	-	-	3	2	3	5,6,7
101.3	-	-	-	-	3	3	3	5,6,7
101.4	-	-	-	-	2	2	3	5,6,7
101.5	-	-	-	-	2	2	3	5,6,7
101.6		-	--	--	2		3	5,7

Test	Units	Marks	Pattern
<b>Mid Sem- I</b>	1. Vocabulary 2. Reading	20	Part A: 4 short answer questions Part B: 2 short essay questions with internal choice Part C: 2 essay questions with internal choice
<b>Mid Sem - II</b>	1. Speaking 2. Grammar-1	20	Part A: 4 short answer questions Part B: 2 short essay questions with internal choice Part C: 2 essay questions with internal choice
<b>Slip Test 1</b>	1. Vocabulary 2. Reading	5	2 questions out of 3 questions
<b>Slip Test 2</b>	1. Speaking 2. Grammar-1	5	2 questions out of 3 questions
<b>Assignment</b>	One assignment per one semester	5	Different assignments of higher order questions that develop problem solving skills and critical thinking should be given
<b>Seminars</b>	One seminar per one semester	5	Oral presentations using audio–visual equipment, charts, etc.
	<b>Total</b>	<b>60</b>	

MID SEM - I EXAM					
S. No.	Unit Name	R	U	A	Remarks
1	Unit - I	1, 2	5 (a) 5 (b)	7 (a) 7 (b)	
2	Unit - II	3, 4	6 (a) 6 (b)	8 (a) 8 (b)	
Total Questions		4	4	4	
MID SEM - II EXAM					
S. No.	Unit Name	R	U	A	Remarks
1	Unit - I	1, 2	5 (a) 5 (b)	7 (a) 7 (b)	
2	Unit - II	3, 4	6 (a) 6 (b)	8 (a) 8 (b)	
Total Questions		4	4	4	

SEMESTER END EXAM						
Sl. NO.	Unit No.	Question to be set for SEE			Remarks	
		R	U	A		
1	I	4	1	9 (a)	13 (a)	
2	II					
3	III		2	10 (a)	14 (a)	
4	IV					
5	V		3	5, 6	9 (b)	13 (b)
					11 (a)	15 (a)
		11 (b)			15 (b)	
6	VI	7, 8		10 (b)	14 (b)	
				12 (a)	16 (a)	
				12 (b)	16 (b)	
Total Questions		8	8	8		

**Legend:**

**Remembering: one mark**

**Understanding: three marks**

**Application: five marks**

### **Suggested Student Activities:**

- Practice conversation / dialogue / speech and answer the questions.
- Group discussions.
- Seminars.
- Review a movie.
- Review a book.
- Narrating a story.
- Chain stories.
- JAM.
- Speak about incidents /events /memories /dreams /role model.
- Interviews of famous personalities.
- Reading for main ideas and specific details.
- Summarizing.
- Picture description.
- Writing a recipe.
- Describing a process.
- Giving directions using maps.
- Surveys.
- Filling forms.
- e-mail etiquette.
- Preparing reports on field visits, experiments, projects.
- General English for competitive exams – Practice the previous year’s question papers of SSC, RRB, TS TRANSCO, TSGENCO, etc.

### **REFERENCES:**

1. Practical English Grammar by A.J Thomson and A.V. Martinet
2. A Course in Phonetics and Spoken English by J. Sethi and P.V Dhamija
3. Word Power Made Easy by Norman Lewis.
4. Keep Talking by Friederike Klippel.
5. More Grammar Games by Mario Rinvoluceri and Paul Davis.
6. Essential English Grammar by Raymond Murphy.
7. Spoken English-A Self Learning Guide to Conversation Practice by V Sasi Kumar.

### **E-learning resources:**

1. [www.duolingo.com](http://www.duolingo.com)
2. [www.bbc.co.uk](http://www.bbc.co.uk)
3. [www.babbel.com](http://www.babbel.com)
4. [www.merriam-webster.com](http://www.merriam-webster.com)
5. [www.ello.org](http://www.ello.org)
6. [www.lang-8.com](http://www.lang-8.com)

7. youtube.com
8. Hello English (app)
9. mooc.org
10. <https://onlinecourses.nptel.ac.in>
11. <https://www.indeed.com/career-advice/>
12. Dictionary.com
13. Online Dictionaries
14. <https://englishsentences.com>
15. <https://englishcub.com/vocabulary/dictionary-thesaurus.htm>
16. TEDx talks.
17. Toastmasters International on YouTube.

**BOARD DIPLOMA EXAMINATION (C-21)**  
**MID SEMESTER EXAMINATION – I**  
**HU-101-BASIC ENGLISH**

**Time: 1 Hour**

**Total Marks: 20**

**PART - A**

**1 X 4 = 4**

*Instructions: Answer all the questions. Each question carries one mark.*

1. Choose the correct guide words for the following words.

1. Pool:

- |                  |                   |
|------------------|-------------------|
| a. Play, Portico | b. Poem, Poet     |
| c. Prosper, Pull | d. Porpoise, Pout |

2. Monkey:

- |                |                |
|----------------|----------------|
| a. Money, Monk | b. Mole, Mount |
| c. Moon, Most  | d. More, move  |

2. \_\_\_\_\_ is the Unit of Electric Current in SI Units named after Andre Marie Ampere.

3. Read the following passage and answer the question.

There once was a Bald Man who sat down after work on a hot summer's day. A Fly came up and kept buzzing about his bald pate, stinging him from time to time. The Man aimed a blow at his little enemy, but his palm came on his head instead; and again the Fly tormented him. But this time the Man was wiser, and said: "You will only injure yourself if you take notice of despicable enemies."

i) How can you say that the man has become wiser?

4. Read the following passage and answer the question.

An Eagle was soaring through the air when suddenly it heard the whizz of an Arrow, and felt itself wounded to death. Slowly it fluttered down to the earth, with its life- blood pouring out of it. Looking down upon the Arrow with which it had been pierced, it found that the shaft of the Arrow had been feathered with one of its own plumes. "Alas!" it cried, as it died. "We often give our enemies the means for our own destruction."

i) What did the eagle discover before its death?

**PART - B**

**3 X 2 = 6**

*Instructions: Answer the following questions. Each question carries three marks*

5. a) Read the following and use correct words in the blanks.

I went to \_\_\_\_\_ (meat/ meet) the \_\_\_\_\_ (Principle / Principal) but he was on \_\_\_\_\_ (live/ leave) for a \_\_\_\_\_ (weak / week). I had to \_\_\_\_\_ (weight / wait) in the room before I was \_\_\_\_\_ (allowed / aloud) to go out.

( OR )

b) Use the following set of words in sentences of your own to express the difference in the meaning.

- i) break - brake      ii) stationery - stationary      iii) waste - waist

6. a) Read the passage and answer the questions.

When I woke up it was broad daylight and the weather had cleared. The storm abated. The Ship was lifted off at night from the sand where she lay by the tie and was driven up almost as far as the rock where I have been bruised by the dashing. As the ship was upright and within a mile, I wish to board it to save necessary things for my use.

- (i) How was the weather in the morning?  
(ii) What had happened to the ship at night?  
(iii) Why did he wish to board the ship?

( OR )

b) Read the passage and answer the questions.

O. Henry's original name was William Sidney Porter, he was born on 11th September, in 1862, Greensboro, North Carolina, U.S. He died on 5th June, 1910, New York. He was an American short story writer whose tales romanticized the commonplace - in particular the life of ordinary people in New York City. His stories expressed the effect of coincidence on character through humour, grim or ironic, and often had surprise endings, a device that became identified with his name and cost him critical favour when its vogue had passed.

- (i) Who was William Sidney Porter?  
(ii) What did his stories deal with?  
(iii) What was the name he took up to write stories?

**PART-C**

**5 X 2 = 10**

*Instructions:* Answer the following questions. Each question carries five marks

7. a) Write the basic uses of a dictionary.

( OR )

b) How will you look up the word, "Travel", in the dictionary.

8. a) Read the passage and answer the questions.

An owl is a bird. There are two basic types of owls: typical owls and bam owls. Owls live in almost every country of the world. Owls are mostly nocturnal, meaning they are awake at night. Owls are predators – they hunt the food that they eat. Owls hunt for mince and other small mammals, insects and even fish. Owls are well adapted for hunting. Their soft, fluffy feathers make their flight nearly silent. They have very good hearing which helps them to hunt well in the darkness. The sharp hooked beaks and claws of the owl makes it very easy to tear apart their prey quickly, although owls also eat some prey whole.

Owl's eyes are unusual. Like most predators, both the eyes of the owl face front. The owl cannot move its eyes. Owls are far – sighted, which means they can see very well far away.... But they can't see dose very well at all. Fortunately, their distant vision is what they use for hunting and they see far away even in low light. Owls have facial disks around their eyes, tufts of feathers in a circle around each eye. These facial disks are thought to help the Owl's hearing. Owls can turn their heads 180 degrees is all the owl needs to see what's going on all around it. Perhaps because of the Owl's mysterious appearance, especially its round eyes and flexible neck, there are a lot of myths and superstitions about Owls. Many cultures believe that Owls are unusually wise. Because owls are nocturnal, some cultures associate owls with bad omens. The screech of the bam owl is considered by many to sound early human, like a person screaming. However, owls probably do not interact with fates of human at all. In fact, some owl species may become extinct because of humans.

- (i) How can you say that an owl is a predator? List a few special features present in predators.
- (ii) What helps owls in hunting?
- (iii) Why are myths and superstitions associated with an owl?
- (iv) Pick out the words from the passage which means:
  - a) A sign of something that will happen in the future.
  - b) In a strange frightening mysterious way.
- (v) What will you do if you see an owl with owlets in your college premises?

( OR )

b) Read the passage and answer the questions.

Marie Curie was born in Poland in 1867. She was the youngest of five children. Her father was a professor. Marie won a gold medal when she graduated from high school. She and her sister did private tutoring to earn money. At Sorbonne University she studied Mathematics and Physics. She earned a master's degree in Physics and with the help of a scholarship earned a master's in Mathematics. Later she received a doctorate in Physics. She met Pierre Curie and married him in 1895. Together they discovered two new radioactive elements. They named them Polonium and Radium. They received the Nobel Prize in the year 1903 for the discovery of Radioactivity along with Hennery Becquerel. In 1911 she received another Nobel Prize for the discovery of Polonium and Radium. In 1923 the French government gave her a pension of forty thousand Francs a year in recognition of her lifetime work in France. Many people have benefited from the discoveries made by Pierre and Marie Curie.

- (i) When and where was Marie Curie born?
- (ii) Why were they awarded the Nobel Prize?
- (iii) Write the antonyms for the following words:
  - a) Benefit
  - b) Youngest
- (iv) Why did the French government give her a pension?
- (v) How can you say many people have benefitted from discoveries made by Pierre and Marie Curie?

**BOARD DIPLOMA EXAMINATION (C-21)**  
**MID SEMESTER EXAMINATION – I**  
**HU-101- BASIC ENGLISH**

**Time: 1 Hour**

**Total Marks: 20**

**PART - A**

**1 X 4 = 4**

*Instructions: Answer all the questions. Each question carries one mark.*

1. Write a sentence to express the trait you like in your friend.
2. Rewrite the sentence using a word of obligation.
  - a) The teacher advised the students to work hard in order to get good marks.
3. Read the following sentence and write the sentence pattern.
  - a) I teach students.
  - b) Farmers are hard working.
4. Fill in the blank with the appropriate form of the verb.
  - a) He \_\_\_\_\_ (live) in that house since 2015.

**PART - B**

**3 X 2 = 6**

*Instructions: Answer the following questions. Each question carries three marks.*

5.
    - a) Write one expression used by the teacher.
      - (i) When the Class is noisy.
      - (ii) When a student is distracted.
      - (iii) When a student is permitted to leave early.
- OR**
- b) Write the feelings you express in the following situations.
    - (i) The train you have been waiting for hours has been cancelled.
    - (ii) Your mother says she is proud of you.
    - (iii) You forgot that a holiday was declared and went to college.
6.
    - a) Change the voice of the following sentences.
      - (i) He eats only vegetarian food.
      - (ii) Ethical hacking has been learnt by Gaurav.
      - (iii) Submit your application.

**OR**

- b) Fill in the blanks with simple past and past continuous forms of the verbs given in the brackets.

When the children \_\_\_\_i\_\_\_\_ (Play) in the park, they \_\_\_\_ii\_\_\_\_ (hear) the whimper of a small puppy. The friends \_\_\_\_iii\_\_\_\_ (search) under the bushes and

\_\_\_\_iv\_\_\_\_ (find) a white puppy. When they \_\_\_\_v\_\_\_\_ (try) to pacify it a big dog suddenly \_\_\_\_vi\_\_\_\_ (appear).

**PART-C**

**5 X 2 = 10**

*Instructions: Answer the following questions. Each question carries five marks.*

7.

- a) Write three difficulties faced by students while learning English. Give suggestion to overcome these difficulties.

**OR**

- b) Write your introduction in a formal situation (You are Anish studying in class XII)

8.

- a) Write a sentence using each of the given sentence patterns.

- a) S V                      b) S V O                      c) S V S C                      d) S V O OC  
e) S VIODO

**OR**

- b) Write your routine using ten verbs.

**BOARD DIPLOMA EXAMINATION (C-21)**  
**END SEMESTER EXAMINATION**  
**HU-101- BASIC ENGLISH**

**Time: 2 Hours**

**Total Marks: 40**

**PART – A**

**8 X 1 = 8**

**Instructions:** 1. Answer all the questions.

2. Each question carries one mark.

1. Read the sentence and capitalize the words which represent the name of a country, month:
  - a. He bought a jersey in jersey.
  - b. They may come in may.
  
2. Rewrite the following sentence in the form of a request: to a friend, to your teacher.  
Lend me your pen.
  
3. Frame “Yes” or “No” question for the following statement.  
I have understood the problem.
  
4. Write the feeling you undergo in the following situation.  
You see a small child working in a hotel at mid night while returning from a party.
  
5. Fill in the blanks with suitable prepositions.  
Sreeni was angry \_\_\_\_\_ her mother \_\_\_\_\_ not permitting her to go to a late-night party.
  
6. Write a sentence about your teacher using two adjectives.
  
7. Write the salutation written to your friend while writing a letter.
  
8. Read the given paragraph and write the topic sentence.

The white Rhino is the largest mammal weighing around 300 Kgs. It has become endangered as humans hunt it for its horns. It has a wide mouth used for grazing and is the most social of all rhino species. White rhinoceroses are found in grassland and savannah habitat. [Herbivore grazers](#) that eat grass, preferring the shortest grains, the white rhinoceros is one of the largest pure grazers. It drinks twice a day if water is available, but if conditions are dry it can live four or five days without water. It spends about half of the day eating, one third resting, and the rest of the day doing various other things.

**PART- B**

**4 X 3 = 12**

**Instructions:** 1. Answer the following questions.

2. Each question carries three marks.

9.
  - a) Read the following passage and answer the questions.

During the summer holidays, I lost my phone. And for the week that I was phoneless, it felt like a disaster. I love my phone. It gives me quick access to information and allows me to constantly be looped in with my friends, to know exactly what is going on in their lives. So, when I didn't have my phone for a week, I felt a slightly sense of FOMO, or if you are not up to speed with the lingo, fear of missing out. By the end of the week, I would have got used to not having a phone and I would have enjoyed the break from social media. But there was still a lingering sense of sadness at the back of my mind that there would be conversations I had missed, messages that there would be conversations I had missed, messages that had been sent, funny videos shared and night time chats that I would probably never get to see.

- i. What felt like a disaster to the writer?
- ii. Why does the writer love his phone?
- iii. How did the writer feel without the phone?

**OR**

- b) Read the following passage and frame two "Wh" questions and one "Yes No" questions:

Dr Seuss was born on March second 1904. He was an American cartoonist and writer. His real name was Theodor Seuss Geisel. He was born in Springfield, Massachusetts. Dr Seuss liked draw and write even as child. The first book that Dr Seuss wrote was titled "And to think that I saw it on Mulberry Street". He wrote it while on a ocean voyage, returning from a trip to Europe. The rhythm of the ship's engine gave him the feeling for the poetry rhythm in the story. Dr Seuss was not a real doctor. He added the "Dr" to his name to honour his dad, who wanted Theodor to become a doctor. Even though he never became a real doctor, he did write books that helped millions of kids to read. Dr Seuss had also used other names, pen names to write books. These names include Theophrastus Seuss, Theo Le Sieg which is his real name spelled backwards, and Rosetta stone. Dr Seuss wrote more than sixty children's books including some which have been made into movies such as "The Lorax", "The Cat in the Hat", "Horton Hears a Who", and "How the Grinch Stole Christmas". He wrote lots of books for children, even though he and his wife never had children of their own. He died at age 87 in San Diego California, USA.

10.

- a) Write as directed.
  - a) Write a sentence expressing what you like about the rainy season.
  - b) Rewrite the sentence using a word of obligation:  
The Doctor told the patient to reduce the intake of salt, if he wants the healthy life.
- c) Write two hobbies you would express while giving your introduction.

**OR**

- b) Write a paragraph in 100 words about a festival you like.
- 11.
- a) Fill in the blanks with the proper order of adjectives given in brackets
- a) He ate \_\_\_\_\_ (green/ English / round / some) apples.
- b) She has \_\_\_\_\_ (lot of / old / interesting) books.
- c) My grandmother had always been \_\_\_\_\_ (slightly bend / fat / short).

**OR**

- b) Fill in the blank with adjectives or prepositions.
- Tiger is a \_\_\_\_\_ animal that lives \_\_\_\_\_ forests. It is \_\_\_\_\_ animal as it feeds \_\_\_\_\_ other animals. Tigers are very \_\_\_\_\_. The body \_\_\_\_\_ tigers is red or orange with black stripes.
- 12.
- a) Write a letter to your friend asking him to write about his college.

**OR**

- b) Write a paragraph on the importance of physical exercise.

**PART-C**

**4 X 5 = 20**

*Instructions: 1. Answer the following questions.  
2. Each question carries five marks.*

- 13.
- a) Write about five different kinds of dictionaries.

**OR**

- b) Read the following passage and write three “Wh” questions and two “yes No” questions.

One of the results of Technology and population growth is increase of pollution throughout the world. According to United Nation’s report the future of all life on earth will be endangered. If man does not control contamination of the environment, It is time, we learn the full extent of the dangers that face mankind.

For instance, here in Egypt, look at River Nile. It is strange to see how everything is thrown into it as if it were litter basket. Instead of keeping it clean and pure, we pollute it. We our-selves, not our enemies, dirty it with our own hands. Some farmers wash themselves, their clothes, their animals, their pots and pans in its water. They even throw away their dead animals, and birds into it. Some people living in cities and towns throw their old tyres and broken bottles and rusty tins into it. Factories throw their waste chemicals and garbage. In this way the Nile water gets poisoned, kills fish, poisons land, weakens crops and destroys health.

So, it would be foolish to shut our eyes to the dangers of the pollution that man causes to the very thing on which his life depends. Please keep Nile clean.

- 14.
- a) Write five problems faced by students while learning English. Write your suggestions to overcome these problems.

**OR**

- b) Write a paragraph about Covid-19 pandemic in 150 words.
15. a) Describe your favourite place using ten adjectives.

**OR**

- b) Fill in the blanks with suitable prepositions.  
He lives \_\_\_\_\_ (in / on) a beautiful cottage \_\_\_\_\_ (beside / besides) the river. There is a pathway \_\_\_\_\_ (between / among) the two flower beds leading \_\_\_\_\_ (to / from) the cottage. He has been living there \_\_\_\_\_ (since / for) his childhood.
16. a) Write a letter to your friend advising him to work hard to get good marks.

( OR )

- b) Write a letter to the editor of The Times of India about the problems faced by the students during the recent monsoon.

## SC-102-BASIC ENGINEERING MATHEMATICS

Course Title	Basic Engineering Mathematics	Course Code	SC-102
SEMESTER	I	Course Group	Foundation
Teaching Scheme in periods ( L : T : P )	4:1: 0	Credits	3 Credits
Methodology	Lecture + Tutorial	Total Contact Periods	75
CIE	60 Marks	SEE	40 Marks

### Pre requisites:

This course requires the basic knowledge of Algebra, Trigonometry in Mathematics at Secondary school level

### Course Outcomes: COs

At the end of the course, the student will have the ability to:

CO 1	Solve simple problems using concepts of Logarithms& Partial Fractions
CO 2	Determine the inverse of a square matrix using matrix algebra
CO 3	Calculate trigonometric ratios of allied and compound angles and Solve simple problems using concepts of multiple and sub multiple angles
CO 4	Understand the concepts of properties of triangles and determine various forms of complex numbers
CO 5	Transform sum or difference of trigonometric ratios into product and vice versa and also solve some problems in inverse trigonometric functions
CO 6	. Solve simultaneous Linear Equations using the concepts of Matrices and Determinants and solve some problems in solutions of triangles

### Course Content:

#### Algebra

#### Unit-I

**Duration: 08Periods (L: 06– T: 02)**

#### 1. Logarithms:

Definition of logarithm and its properties, natural and common logarithms; the meaning of  $e$  and exponential function, logarithm as a function and its graphical representation – Solve some simple problems.

#### 2. Partial Fractions:

Definition of Rational, proper and improper fractions of polynomials. Resolving rational fractions in to their partial fractions covering the types mentioned below:

$$i) \frac{f(x)}{(x+a)(x+b)(x+c)} \quad ii) \frac{f(x)}{(x+a)^2(x+b)(x+c)}$$

$$iii) \frac{f(x)}{(x^2+a)(x+b)} \quad iv) \frac{f(x)}{(x+a)(x^2+b)^2}$$

## UNIT-II

**Duration: 16 Periods (L: 12 – T:**

**04)**

- 1. Matrices and Determinants:** Definition of matrix, types of matrices-examples, algebra of matrices-equality of two matrices, sum, difference, scalar multiplication and product of matrices. Transpose of a Matrix- Symmetric, Skew symmetric matrices- Minor, cofactor of an element-Determinant of a square matrix up to 3rd order -Laplace's expansion, properties of determinants. Singular and non-singular matrices- Adjoint and multiplicative inverse of a square matrix –related problems.

### Trigonometry:

## Unit-III

**Duration: 14 Periods (L: 12 – T:**

**02)**

- 1. Compound angles:** Formulae of Sin (A±B), Cos (A±B), Tan (A±B), Cot(A±B), and related identities with problems - Derive the values of  $\sin 15^\circ$ ,  $\cos 15^\circ$ ,  $\sin 75^\circ$ ,  $\cos 75^\circ$ ,  $\tan 15^\circ$ ,  $\tan 75^\circ$  etc.-Derive identities like  $\sin(A+B) \sin(A-B) = \sin^2 A - \sin^2 B$  etc.,
- 2. Multiple and sub multiple angles:** Trigonometric ratios of multiple angles 2A, 3A and submultiples angle A/2 with problems - Derive useful allied formulas like

$$\sin^2 A = \left( \frac{1 - \cos 2A}{2} \right) \text{ etc., - Solve simple problems using the above formulae}$$

## Unit – IV

**Duration: 10 Periods (L: 08– T:**

**2.0)**

- 1. Properties of triangles:** Statements of Sine rule, Cosine rule, Tangent rule and Projection rule and solve some simple problems using above rules

2. **Hyperbolic functions:** Definitions of hyperbolic functions – Sin h(x), Cos h(x) , Tan h(x) etc., - identities of hyperbolic functions, inverse hyperbolic functions and expression of inverse hyperbolic functions in terms of logarithms.
3. **Complex Numbers:** Definition of a complex number, Modulus and conjugate of a complex number, Arithmetic operations on complex numbers, Modulus- Amplitude (polar) form, Exponential (Euler) form of a complex number.

## Algebra & Trigonometry

### Unit – V

**Duration: 13Periods (L: 11 – T:**

**2.0)**

1. **Transformations:** Transformation of products into sums or differences and vice versa - Simple problems - Solve problems by applying these formulae to sum or difference or product
2. **Inverse trigonometric functions:** Define inverses of six trigonometric functions along with their domains and ranges - Derive relations between inverse trigonometric functions so that given  $A = \sin^{-1}x$ , express angle A in terms of other inverse trigonometric functions - with examples - State various properties of inverse trigonometric functions and identities like  $\sin^{-1}x + \cos^{-1}x = \frac{\pi}{2}$  etc - solve simple problems. like  $\tan^{-1}x + \tan^{-1}y = \tan^{-1}\left(\frac{x+y}{1-xy}\right)$  where  $x \geq 0$ ,  $y \geq 0$ ,  $xy < 1$

### Unit – VI

**Duration: 14 Periods (L:11– T:03)**

1. **Solution of Simultaneous equations using Matrices & Determinants.:** System of linear equations in 3 Variables-Solutions by Cramer's rule, Matrix inversion method – Examples- Elementary row operations on Matrices -Gauss-Jordan method to solve a system of equations in 3 unknown variables
2. **Solutions of triangles:** Solve a triangle when (i) Three sides (SSS) (ii) Two sides and an Included angle (SAS) (iii) One side and two angles are given (SAA) - Simple problems.

## References

1. Text Book of Matrices – by Shanti Narayan
2. Plane Trigonometry - by S. L. Loney
3. NCERT Mathematics Text Books Of Class XI, XII.
4. Intermediate Mathematics Text Books (Telugu Academy)

## Suggested E-Learning references

1. [www.freebookcentre.net/mathematics/introductory-mathematics-books.html](http://www.freebookcentre.net/mathematics/introductory-mathematics-books.html)
2. E-books:www.mathebook.net

## Suggested Learning Outcomes:

At the end of the course, the student will have the ability to:

## Algebra

### UNIT – I

#### 1.0 Use Logarithms in engineering calculations

- 1.1 Solve some simple Logarithm problems. Using logarithm properties
- 1.2 Distinguish natural logarithms and common logarithms.
- 1.3 Explain the meaning of e and exponential function.
- 1.4 Understand logarithm as a function and its graphical representation.

#### Resolve Rational Fraction into sum of Partial Fractions in engineering problems

- 1.5 Define the following fractions of polynomials:
  - i) Rational
  - ii) Proper and
  - iii) Improper
- 1.6 Resolving rational fractions of the type mentioned below into partial fractions

$$\begin{array}{ll} i) \quad \frac{f(x)}{(x+a)(x+b)(x+c)} & ii) \quad \frac{f(x)}{(x+a)^2(x+b)(x+c)} \\ iii) \quad \frac{f(x)}{(x^2+a)(x+b)} & iv) \quad \frac{f(x)}{(x+a)(x^2+b)^2} \end{array}$$

### UNIT – II

#### 2.0 Use Matrices for solving engineering problems:

- 2.1 Know the matrix and types of a matrix.
- 2.2 Compute sum, difference, scalar multiplication and product of matrices.
- 2.3 Know the properties of these operations such as associative, distributive, commutative properties with examples and counter examples.
- 2.4 Define the transpose of a matrix and write its properties.
- 2.5 Define symmetric and skew-symmetric matrices.

- 2.6 Resolve a square matrix into a sum of symmetric and skew- symmetric matrices with examples in all cases.
- 2.7 Define minor, co-factor of an element of a 3x3 square matrix with examples.
- 2.8 Expand the determinant of a 3 x 3 matrix using Laplace expansion formula.
- 2.9 Distinguish singular and non-singular matrices.
- 2.10 Apply the properties of determinants to solve problems.
- 2.11 Compute Adjoint and multiplicative inverse of a square matrix.

### **Trigonometry:**

### **UNIT – III**

#### **3.0 Solve simple problems on Compound Angles**

- 3.1 Understand the compound angles and able to write the formulae of Sin (A±B), Cos (A±B), Tan(A±B) and Cot(A±B)
- 3.2 Able to derive the values of Sin15<sup>0</sup>, Cos15<sup>0</sup>, Tan 15<sup>0</sup> and Sin75<sup>0</sup>, Cos75<sup>0</sup>, Tan75<sup>0</sup> etc.
- 3.3 Derive identities like Sin (A+B), Sin (A-B) = sin<sup>2</sup> A – sin<sup>2</sup>B etc.,
- 3.4 Solve simple problems on compound angles.

#### **Solve problems using the formulae for Multiple and Sub- Multiple Angles**

- 3.5 Derive the formulae of multiple angles 2A, 3A etc and sub multiple angles A/2 in terms of angle A of trigonometric functions.
- 3.6 Derive useful allied formulas like  $\sin^2 A = \left( \frac{1 - \cos 2A}{2} \right)$  etc.,
- 3.7 Solve simple problems using the above formulae

### **UNIT – IV**

#### **4.0 Appreciate Properties of triangles:**

- 4.1 Understand the sine, cosine, tangent and projection rules. Solve some simple problems

#### **Represent the Hyperbolic Functions in terms of logarithm functions**

- 4.2 Understand Sin h x, Cos h x and Tan h x and list the hyperbolic identities.
- 4.3 Represent inverse hyperbolic functions in terms of logarithms.

#### **Represent Complex numbers in various forms:**

- 4.4 Understand the complex number, its modulus, and conjugate and list their properties.

4.5 Represent the complex number in various forms like modulus-amplitude (polar) form, Exponential (Euler) form – illustrate with examples.

## UNIT – V

### 5.0 Apply Transformations for solving the problems in Trigonometry:

- 5.1 Derive the formulae on transforming sum or difference of two trigonometric ratios in to a product and vice versa- examples on these formulae.
- 5.2 Solve problems by applying these formulae to sum or difference or product of three or more terms.

### Use Inverse Trigonometric Functions for solving engineering problems:

- 5.3 Know the concept of the inverse of a trigonometric function by selecting an appropriate domain and range.
- 5.4 Derive relations between inverse trigonometric functions so that given  $A = \sin^{-1}x$ , express angle A in terms of other inverse trigonometric functions - with examples.
- 5.5 State various properties of inverse trigonometric functions and identities like  $\sin^{-1}x + \cos^{-1}x = \frac{\pi}{2}$  etc.
- 5.6 Solve some problems like  $\tan^{-1}x + \tan^{-1}y = \tan^{-1}\left(\frac{x+y}{1-xy}\right)$  where  $x \geq 0, y \geq 0$   
And  $xy \leq 1$

## UNIT – VI

### 6.0 Apply Matrices and Determinants in solving system of Linear Equations:

- 6.1 Solve system of linear equations with 2 and 3 unknown variables using Cramer's rule.
- 6.2 Solve system of linear equations with 2 and 3 unknown variables by matrix inversion method
- 6.3 State elementary row operations.
- 6.4 Solve a system of linear equations in 3 unknown variables by Gauss- Jordan method

### Apply Properties of Triangles to solve a triangle.

- 6.5 Solve a triangle when
  - i. Three sides (SSS)
  - ii. Two sides and an included angle (SAS),
  - iii. One side and two angles are given (SAA).

### Suggested Student Activities

1. Student visits Library to refer Standard Books on Mathematics and collect related material.
2. Quiz
3. Group discussion
4. Surprise tests
5. Seminars
6. Home Assignments.
7. Mathematics- for preparing competitive exams and solve some arithmetical ability exam Questions

### CO / PO - MAPPING

CO	PO1	PO2	PO3	PO4	PO5	PO6	PO7	Mapped POs
CO1	3	1					3	1,2,7
CO2	3	2					3	1,2,7
CO3	3	2					3	1,2,7
CO4	3	2					3	1,2,7
CO5	3	2					3	1,2,7
CO6	3	2					3	1,2,7

### MID SEM-I EXAM

S.No	Unit Name	R	U	A	Remarks
1	Unit-I	1, 2	5(a) 5(b)	7(a) 7(b)	
2	Unit-II	3, 4	6(a) 6(b)	8(a) 8(b)	
Total Questions		4	4	4	

### MID SEM –II EXAM

S.No	Unit Name	R	U	A	Remarks
1	Unit-III	1, 2	5(a) 5(b)	7(a) 7(b)	
2	Unit-IV	3, 4	6(a) 6(b)	8(a) 8(b)	
Total Questions		4	4	4	

### Semester End Examination

Sl No	Unit No.	Questions to be set for SEE			Remarks	
		R	U	A		
1	I	4	1	9(a)	13(a)	
2	II					
3	III		2	10(a)	14(a)	
4	IV					
5	V	4	3	5, 6	9(b) 11(a) 11(b)	13(b) 15(a) 15(b)
6	VI			7,8	10(b)	14(b)
					12(a) 12(b)	16(a) 16(b)
Total Questions		8	8	8		

Legend:	Remembering (R)	1 Mark
	Understanding (U)	3 Marks
	Application (A)	5 Marks

**BOARD DIPLOMA EXAMINATIONS (C21)**  
**MID SEMESTER EXAMINATIONS - I**  
**SC-102 - BASIC ENGINEERING MATHEMATICS**

**TIME: 1: 00 Hour**

**Max. Marks: 20**

**PART-A**

Instructions: 1. Answer **ALL** questions 04 X 01 = 04

2 Each question carries **ONE** mark

1. Find the value of  $\log_8 2$
2. Define Proper fraction and give an example.
3. If  $A = \begin{bmatrix} 1 & 2 \\ -2 & 3 \end{bmatrix}$  and  $B = \begin{bmatrix} 4 & -1 \\ 3 & 2 \end{bmatrix}$  Then Compute  $3A + 5B$ .
4. Find the value of  $\begin{vmatrix} 1 & 2 \\ 3 & 4 \end{vmatrix}$ .

**PART-B**

Instructions: 1. Answer All questions 02 X 03 = 06

2. Each question carries **THREE** marks

- 5.
- a) Resolve:  $\frac{x}{(x-1)(x-2)}$  into partial fractions

**OR**

- b) Find the value of  $\log_2 16 + 3\log_8 32$

6.

- a) If  $\begin{pmatrix} 2 & 1 & 2 \\ 1 & 4 & 1 \\ 1 & 3 & 2 \end{pmatrix}$ , then Compute  $A^2 + 2A - 3I$ , where **I** is a unit matrix of order 3

**OR**

- b) Find x if  $\begin{vmatrix} 1 & 0 & 0 \\ 2 & 3 & 4 \\ 5 & -6 & x \end{vmatrix} = 48$

**PART C**

Instructions: 1. Answer All questions

02 X 05 = 10

2. Each question carries **FIVE** marks

7.

a) Resolve  $\frac{9}{(x-1)(x+2)^2}$  into Partial fractions:

**OR**

b) Prove that  $\log\left(\frac{75}{60}\right) - 2\log\left(\frac{5}{9}\right) + \log\left(\frac{32}{243}\right) = \log 2$

8.

a) If  $A = \frac{1}{3} \begin{bmatrix} 1 & 2 & 2 \\ 2 & 1 & -2 \\ -2 & 2 & -1 \end{bmatrix}$ , then show that  $A^{-1} = A^T$

**OR**

b) Show that  $\begin{vmatrix} b+c & a & a \\ b & c+a & b \\ c & c & a+b \end{vmatrix} = 4abc$ .

@@@



### PART C

Instructions: 1. Answer All questions

02 X 05 = 10

2. Each question carries **FIVE** marks

7.

a) Prove that 
$$\frac{(\tan A + \sec A - 1)\cos A}{\sin A + \cos A - 1} = \frac{1 + \sin A}{\cos A}$$

**OR**

b) Prove that 
$$\cos^2 A + \cos^2 (60^\circ + A) + \cos^2 (60^\circ - A) = \frac{3}{2}$$

8.

a) Find the additive and multiplicative Inverse of  $4 + 3i$

**OR**

b) Express the complex number  $\frac{1+i}{1-i}$  in Exponential form

@@@

**BOARD DIPLOMA EXAMINATION (C-21)**  
**SEMESTER END EXAMINATION**  
**SC-102- BASIC ENGINEERING MATHEMATICS**

Time: 2 hours

[Total Marks: 40]

---

**PART-A**

Instructions: 1. Answer **ALL** questions 08 X 01 = 08

2 Each question carries **ONE** mark

1. Define proper fraction.
2. Write the formula for  $\cos(A + B)$  and  $\tan(A + B)$
3. Define solution of a triangle.
4. Find the value of  $\log_4 16$ .
5. Convert  $\sin 6\theta + \sin 8\theta$  in to product
6. If  $\sin^{-1} \frac{3}{5} = A$  then find  $\cot A$ .
7. List the elements of a triangle ABC.
8. What is the formula for the solution of triangle ABC when three sides are given

**PART-B**

Instructions: 1. Answer All questions 04 X 03 = 12

2. Each question carries **THREE** marks

9 (a) Resolve :  $\frac{9}{(x-1)(x+2)^2}$  into Partial fractions:

9 (b) Prove that  $\frac{\sin 8\theta + \sin 6\theta}{\cos 8\theta + \cos 6\theta} = \tan 7\theta$

10 (a) Express  $\frac{9}{4+3i}$  in the form of  $a + bi$ .

Or

10(b) Solve the triangle ABC with  $a=2$ ,  $A=30^\circ$ ,  $C=30^\circ$ .

11(a) Prove that  $\sin 50^\circ - \sin 70^\circ + \sin 10^\circ = 0$ .

Or

11(b) Prove that  $\tan^{-1} \frac{2}{7} + \tan^{-1} \frac{1}{5} = \tan^{-1} \frac{17}{33}$ .

12(a) Solve  $\begin{bmatrix} 3 & 2 \\ 2 & -3 \end{bmatrix} \begin{bmatrix} x \\ y \end{bmatrix} = \begin{bmatrix} 4 \\ 7 \end{bmatrix}$ .

Or

12 (b) Find the angle C in any triangle ABC if  $b = \sqrt{2}$ ,  $c = \sqrt{3}$ ,  $B = 45^\circ$ .

**PART C**

Instructions: 1. Answer All questions

04 X 05 = 20

2. Each question carries **FIVE** marks

13(a) Find the Adjoint of the matrix  $\begin{bmatrix} 1 & 3 & 4 \\ -1 & 2 & 1 \\ 0 & 3 & 3 \end{bmatrix}$

Or

13 (b) Prove that  $\sin \theta + \sin(120^\circ + \theta) - \sin(120^\circ - \theta) = 0$

14 (a) Prove that  $\cos 6^\circ \cdot \cos 42^\circ \cdot \cos 66^\circ \cdot \cos 78^\circ = \frac{1}{6}$

(b) Solve:  $x + y + z = 6$ ,  $x + 2y + 3z = 14$ ,  $x + 4y + 9z = 3$  by using inverse Matrix method.

15(a) In any triangle ABC prove that  $\sin 2A + \sin 2B + \sin 2C = 4 \sin A \sin B \sin C$

15(b) if  $\tan^{-1} x + \tan^{-1} y + \tan^{-1} z = \frac{\pi}{2}$  then prove that  $xy + yz + zx = 1$

16(a) Solve:  $x + 2y - z = -3$ ,  $3x + y + z = 4$ ,  $x - y + 2z = 6$  by Cramer's Rule.

Or

16 (b) Solve the triangle ABC with  $a = 1$   $b = 2$   $c = \sqrt{2}$ .

@@@

### SC-103 BASIC PHYSICS

Course Title	Basic Physics	Course Code	SC-103
Semester	Semester-I	Course Group	Foundation
Teaching Scheme in Pds(L:T:P)	4:1:0	Credits	3
Type of course	Lecture+Tutorial	Total Contact Periods	75
CIE	60 Marks	SEE	40 Marks

**Pre requisites:** High School Science and Mathematics

**Course Objectives:** After studying this course, the student will be able to understand and appreciate the role of Physics in different areas of engineering and technology.

**Course outcomes:** On successful completion of the course, the student will have the ability to attain below Course Outcomes (CO):

CO1	Identify physical quantities, select their units for use in engineering solutions, and make measurements with accuracy by minimizing different types of errors.
CO2	Apply laws of Vectors as tools to solve engineering problems
CO3	Explain friction on horizontal and inclined surfaces, analyze projectile and circular motions and apply the formulation to projectiles and central forces and solve engineering problems
CO4	Explain Hooke's law, properties of fluids viz surface tension, viscosity and significance of Reynolds's number and apply Bernoulli's principle to solve engineering problems
CO5	Apply conservation laws to various energy sources
CO6	Apply Heat and thermodynamic processes and formulate to understand engineering problems

CO	PO1	PO2	PO3	PO4	PO5	PO6	PO7
CO1	3	-	-	-	-	-	2
CO2	3	1	-	-	-	-	2
CO3	3	1	-	-	-	-	2
CO4	3	1	-	1	-	-	2
CO5	3		-	-	1	-	2
CO6	3	1	-	-	-	-	2
	3	1		1	1		2

## SC-103 - BASIC PHYSICS

### Course Contents

#### 1. UNIT - 1 UNITS, DIMENSIONS AND MEASUREMENTS

**Duration: 12 periods**

Physical quantity – Fundamental and derived quantities, unit – definitions – system of units – Advantages of S.I. units

Dimensions and dimensional formula – definitions, units and dimensional formulae for physical quantities, Dimensionless quantities, Principle of homogeneity, Applications of dimensional analysis – Checking the correctness of physical equations – conversion of unit from one system to another system – problems on density, force and energy

Error in measurement – accuracy and precision of instruments, rules for representing significant figures-Numerical problems

#### 2. UNIT – 2 VECTORS

**Duration: 13 periods**

Scalar and Vector quantities – definition and examples, representation of a vector, Classification of vectors - Proper vector, Equal vectors, Unit vector, Negative vector, null vector and Position vector, Resolution of a vector.

Lami's theorem, Parallelogram law of vectors – statement- expression for magnitude and direction of resultant vector –derivation- illustrations(working of sling and flying bird), Representation of a vector in unit vectors  $\mathbf{i}$ ,  $\mathbf{j}$  and  $\mathbf{k}$ . – numerical problems.

Scalar product of vectors- application to work done by force and power – properties of scalar product. – Numerical problems.

Vector product of vectors– Right hand thumb rule and right hand screw rule - application to torque - properties of vector product - Application to area of parallelogram and triangle -numerical problems.

#### 3. UNIT -3 MECHANICS

**Duration: 13 periods**

Concept of Friction - Normal reaction, Angle of friction, Motion of a body over a rough horizontal surface - expressions for Acceleration, Displacement, Time taken to

come to rest - derivations, inclined plane - Motion of a body over a smooth inclined plane and rough inclined plane—forces acting on the body -angle of repose, Application of friction – brake system in bicycle– numerical problems

Projectile motion – definition – examples, Horizontal projection - Oblique projection, Expression for path of a projectile in oblique projection –derivation, Maximum height, Time of ascent, Time of descent, Time of flight, Horizontal range and maximum horizontal range in oblique projection– derivations, numerical problems

Circular motion – definition of angular displacement, angular velocity, angular acceleration, frequency and time period, Relation between linear and angular velocity – derivation – related numerical problems, Central force – examples, Expressions for centripetal and centrifugal forces (no derivation), Applications of centripetal and centrifugal forces - Banking of roads and its expression, bending of cyclist and principle of centrifuge - related numerical problems.

#### **4. UNIT – 4 PROPERTIES OF MATTER**

**Duration: 12 periods**

Elasticity – Elastic body –definition - examples, Stress and Strain – definitions and expressions, types of stress and strain, elastic limit - Hooke’s law – statement – modulus of elasticity, significance of stress and strain curve -Young’s modulus – Derivation, numerical problems

Cohesive and Adhesive forces - Surface tension - Capillarity –angle of contact – definition- examples for capillarity- Formula for Surface tension based on capillarity (no derivation), effect of temperature and impurity on surface tension, applications and illustrations of surface tension, numerical problems.

Viscosity - Newton’s formula for viscous force – derivation - Coefficient of viscosity - Poiseuille’s equation (formula only), Effect of temperature on viscosity of liquids and gases, applications of viscosity, numerical problems.

Concept of fluid motion –streamline and turbulent flow, Reynold’s number, equation of continuity, Bernoulli’s theorem (only formula) and applications - related problems.

#### **5. UNIT – 5 CONSERVATION LAWS AND ENERGY SOURCES**

**Duration: 12 periods**

Work, Power and Energy – explanation, Potential Energy and Kinetic energy– examples – expressions for Potential energy and Kinetic energy– derivations, Work-Energy theorem – derivation, Law of conservation of energy – examples, Law of conservation of energy in the case of freely falling body – proof – Illustration of

conservation of energy in the case of simple pendulum, Nonrenewable and renewable energy sources – definition and applications (solar cooker, wind mill and biogas plant), Green House effect, Energy conservation (saving) methods - domestic and industrial, related problems

## **6. UNIT – 6 HEAT**

**Duration: 13 periods**

Heat – thermal expansion of solids – Coefficients of expansions, different scales of temperature- Centigrade and Fahrenheit and their relationship, Bimetallic strip – applications in daily life - electric heater thermostat- circuit breaker-iron box, Boyle’s law – statement, concept of absolute zero - Absolute scale of temperature, Charles’ laws, Ideal gas equation – derivation - value of universal gas constant ‘R’, Gas equation in terms of density, Isothermal and Adiabatic processes - Differences between isothermal and adiabatic processes, Internal energy and External work done, Expression for work done – derivation, first law of thermodynamics –application of first law to isothermal and adiabatic processes, second law of thermodynamics, specific heats of a gas, related numerical problems.

### **LEARNING OUTCOMES:**

**Upon completion of the course the student shall be able to**

### **UNITS, DIMENSIONS AND MEASUREMENTS**

- 1.1 Define Physical quantity, fundamental quantity and derived physical quantity.
- 1.2 Classify system of units (FPS, CGS, MKS and SI) and outline advantages of S.I. units.
- 1.3 Write S.I. units of physical quantities.
- 1.4 Define Dimensions and dimensional formulae of physical quantities.
- 1.5 List dimensional formulae of physical quantities.
- 1.6 List dimensionless quantities.
- 1.7 Explain Principle of homogeneity of dimensions.
- 1.8 List the applications of dimensional formulae.
- 1.9 List the limitations of dimensional analysis.
- 1.10 Apply dimensional formulae to check the correctness of physical equations and to convert a unit from one system to another system (density, force and energy).
- 1.11 Define accuracy and precision of instruments, random and systematic errors.
- 1.12 List the rules for representing significant figures.
- 1.13 Solve simple numerical problems.

### **VECTORS**

- 2.1 Define Scalar and Vector quantities with examples.

- 2.2 Represent a vector graphically and label vector characteristics.
- 2.3 Classify Vectors - Proper vector, Equal vector, Unit vector, Negative vector, Null vector and Position vector.
- 2.4 Resolve a Vector into two orthogonal components.
- 2.5 Explain Lami's theorem.
- 2.6 Explain Parallelogram law of vectors and develop expressions for magnitude and direction of resultant vector.
- 2.7 Illustrate parallelogram law of vectors (working of sling and flying bird).
- 2.8 Represent a vector in terms of unit vectors ( $\hat{i}, \hat{j}, \hat{k}$ ).
- 2.9 Explain Scalar product of vectors.
- 2.10 Apply scalar product to work done by force and power.
- 2.11 List the properties of scalar product.
- 2.12 Explain vector product of vectors.
- 2.13 Explain right hand thumb rule and right hand screw rule.
- 2.14 Apply vector product to explain torque.
- 2.15 List the properties of vector product.
- 2.16 Extend vector product to area of parallelogram and area of triangle.
- 2.17 Solve related numerical problems.

## MECHANICS

- 3.1 Explain concept of friction.
- 3.2 Explain Normal reaction and Angle of friction.
- 3.3 Derive expression for acceleration of a body on a rough horizontal surface.
- 3.4 Derive expressions for displacement and time taken to come to rest by a body over a rough horizontal surface.
- 3.5 Explain and label the forces acting on a body moving over smooth and rough inclined planes.
- 3.6 Define angle of repose.
- 3.7 Apply friction in brake system of moving vehicles such as bicycle.
- 3.8 Explain and classify Projectile motion with examples.
- 3.9 Derive expression for path of a projectile in oblique projection.
- 3.10 Develop formulae for Maximum height, Time of ascent, Time of descent, Time of flight, Horizontal range and maximum horizontal range of a projectile in oblique projection.
- 3.11 Explain circular motion and define angular displacement, angular velocity, angular acceleration, frequency and time period.
- 3.12 Develop a relation between linear velocity and angular velocity.
- 3.13 Explain Central force with examples and outline expressions for Centripetal and Centrifugal forces.
- 3.14 Apply centripetal and centrifugal forces to banking of roads, bending of cyclist and centrifuge.

3.15 Solve related numerical problems.

## **PROPERTIES OF MATTER**

- 4.1 Define Elasticity and elastic bodies with examples.
- 4.2 Define Stress and Strain with their expressions.
- 4.3 Explain types of stress and strain.
- 4.4 Define Elastic limit.
- 4.5 Explain Hooke's law.
- 4.6 Outline the significance of stress and strain curve.
- 4.7 Develop a formula for Young's modulus of a wire having circular cross-sectional area.
- 4.8 Compare Cohesive and Adhesive forces.
- 4.9 Explain Surface tension and illustrate Surface tension with examples.
- 4.10 Define capillarity and angle of contact.
- 4.11 Outline the formula for Surface tension based on capillarity ( $T = \frac{1}{2} h d \rho g$ ).
- 4.12 Effect of temperature and impurity on surface tension of a liquid.
- 4.13 Explain Viscosity.
- 4.14 Develop Newton's formula for viscous force and explain coefficient of viscosity.
- 4.15 Outline Poiseuille's equation for coefficient of viscosity.
- 4.16 Explain the effect of temperature on viscosity of liquids and gases.
- 4.17 Identify the importance of viscosity in blood flow through arteries, liquid soap, paint, lubricants and braking oil.
- 4.18 Explain Streamline flow and Turbulent flow.
- 4.19 Define Reynold's number and explain its significance.
- 4.20 Outline the Equation of Continuity and explain the terms with diagram.
- 4.21 Explain Bernoulli's theorem.
- 4.22 Apply Bernoulli's theorem to dynamic lift (aero foil lift, swing of a ball, blowing of roofs, atomizer, Bunsen burner).
- 4.23 Solve related numerical problems.

## **CONSERVATION LAWS AND ENERGY SOURCES**

- 5.1 Explain concept of Work, Power and Energy.
- 5.2 Explain Potential energy and Kinetic energy with examples.
- 5.3 Develop expressions for Potential energy and Kinetic energy.
- 5.4 State Work-Energy theorem and prove the relation.
- 5.5 State law of conservation of energy with examples.
- 5.6 Prove law of conservation of energy in the case of a freely falling body.
- 5.7 Illustrate law of conservation of energy in the case of simple pendulum.
- 5.8 Explain Non-renewable and Renewable energy sources and list the examples.
- 5.9 Explain Solar cooker, Wind mill and Biogas plant with neat diagrams.
- 5.10 Explain Green House effect.
- 5.11 List domestic and industrial energy conservation methods.

5.12 Solve related numerical problems.

## HEAT

- 6.1 Explain thermal expansion of solids and three coefficients of expansion of solids.
- 6.2 Outline Centigrade and Fahrenheit scales of temperature and relate them.
- 6.3 Explain principle of Bimetallic strip.
- 6.4 Apply principle of bimetallic strip to electric water heater thermostat, circuit breaker and iron box.
- 6.5 Explain Boyle's law in gases and its limitations.
- 6.6 Explain concept of Absolute Zero using the relations  $P_t = P_0[1 + \frac{t}{273}]$  and  $V_t = V_0[1 + \frac{t}{273}]$ .
- 6.7 Explain Absolute scale of temperature.
- 6.8 Explain Charles' laws in gases in terms of absolute temperature.
- 6.9 Develop Ideal gas equation and calculate the value of Universal gas constant.
- 6.10 Translate gas equation in terms of density.
- 6.11 Explain Isothermal and Adiabatic processes and distinguish between them.
- 6.12 Explain the terms internal energy and external work done.
- 6.13 Derive the expression for work done by the gas [ $W=P(V_2-V_1)$ ].
- 6.14 Explain first law of thermodynamics and list applications of it.
- 6.15 Apply first law of thermodynamics to isothermal and adiabatic processes.
- 6.16 Explain second law of thermodynamics and list applications of it.
- 6.17 Define specific heats and molar specific heats of a gas.
- 6.18 Solve related numerical problems.

## References:

1. Principles of Physics by N. Subrahmanyam and Brijlal, S. Chand & Co, New Delhi, edition, 1982
2. Engineering. Physics by R.K. Gaur, S.L. Gupta, Dhanpatrai Publications, New Delhi.
3. ISC Physics, Book I&II, P. Vivekanandan, DK Banerjee, S Chand, New Delhi.
4. Intermediate Physics, Vol. I&II, Telugu Academy, TS, Hyderabad.
5. Fundamentals of Physics by Halliday and Resnick.

## E-learning resources:

1. Hyper Physics website: <http://hyperphysics.phy-astr.gsu.edu/>

### MID SEM-I EXAM

S.No	Unit Name	R	U	A	Remarks
1	Unit-I	1, 2	5(a) 5(b)	7(a) 7(b)	
2	Unit-II	3, 4	6(a) 6(b)	8(a) 8(b)	
Total Questions		4	4	4	
<b>MID SEM –II EXAM</b>					
S.No	Unit Name	R	U	A	Remarks
1	Unit-III	1, 2	5(a) 5(b)	7(a) 7(b)	
2	Unit-IV	3, 4	6(a) 6(b)	8(a) 8(b)	
Total Questions		4	4	4	

### Semester End Examination

Sl No	Unit No.	Questions to be set for SEE			Remarks		
		R	U	A			
1	I	4	1	9(a)	13(a)		
2	II			10(a)	14(a)		
3	III		3	5, 6	9(b)	13(b)	
4	IV				11(a)	15(a)	
5	V			11(b)	15(b)		
6	VI			7,8	10(b)	14(b)	
		12(a)	16(a)				
		12(b)	16(b)				
Total Questions		8	8	8			

Legend:	Remembering (R)	1 Mark
	Understanding (U)	3 Marks
	Application (A)	5 Marks

**BOARD DIPLOMA EXAMINATION (C-21)**  
**MID SEM-I**  
**FIRST SEMESTER EXAMINATION**  
**SC-103 - BASIC PHYSICS**

**Time: 1 Hour**

**Total Marks: 20**

---

**PART-A**

Instructions: 1. Answer **ALL** questions.  
2. Each question carries **ONE** mark. 4X1 =4

1. Define fundamental physical quantity.
2. Write dimensional formula for work.
3. Define vector quantity.
4. Define unit vector.

**PART-B**

Instructions: 1. Answer **ALL** questions.  
2. Each question carries **THREE** marks. 2X3 =6

5. (a). Outline three applications of dimensional analysis.  
(OR)  
(b). Outline any three rules for representing significant figures.
6. (a). Explain Lami's theorem.  
(OR)  
(b). Explain right hand screw rule of vector product.

**PART-C**

Instructions: 1. Answer **ALL** questions.  
2. Each question carries **FIVE** marks. 2X5 =10

7. (a). By applying the dimensional analysis convert CGS unit of energy into SI units of energy.  
(OR)  
(b). Check the correctness of the following equations by applying Principle of homogeneity?  
1)  $s = ut + \frac{1}{2} at^2$       2)  $v^2 - u^2 = 2 as$
8. (a). Derive expression for magnitude and direction of resultant vector by applying parallelogram law of vectors.  
(OR)  
(b). Two vectors are  $\vec{A} = 3\vec{i} - 3\vec{j} + \vec{k}$  and  $\vec{B} = 4\vec{i} + 9\vec{j} + 2\vec{k}$ . Solve  $\vec{A} \times \vec{B}$

**BOARD DIPLOMA EXAMINATION (C-21)**  
**MID SEM –II**  
**FIRST SEMESTER EXAMINATION**  
**SC-103 - BASIC PHYSICS**

**Time: 1 Hour**

**Total Marks: 20**

---

**PART-A**

- Instructions: 1. Answer **ALL** questions.  
2. Each question carries **ONE** mark.

4X1 =4

1. Define angle of friction.
2. Define central force.
3. Define stress.
4. Define Reynold's number.

**PART-B**

- Instructions: 1. Answer **ALL** questions.  
2. Each question carries **THREE** marks.

2X3 =6

5. (a). Explain the forces acting on the body moving up on a rough inclined plane.  
(OR)  
(b). Derive the relation between linear velocity and angular velocity.
6. (a). Explain the effect of temperature on viscosity of liquids and gases.  
(OR)  
(b). Explain Bernoulli's theorem.

**PART-C**

- Instructions: 1. Answer **ALL** questions.  
2. Each question carries **FIVE** marks.

2X5 =10

7. (a). Develop expressions for maximum height and horizontal range of a projectile in oblique motion.  
(OR)  
(b). Develop the expression for angle of banking of roads.
8. (a). Develop formula for young's modulus of a wire having circular cross-sectional area.  
(OR)  
(b). Apply Bernoulli's theorem to dynamic aero foil lift.

\*\*\*\*

**BOARD DIPLOMA EXAMINATION, (C-21)**  
**FIRST SEMESTER EXAMINATION**  
**SC-103 - BASIC PHYSICS**

Time: 2 Hours]

[Total Marks: 40

---

**PART – A**

- Instructions: 1. Answer **ALL** questions.  
2. Each question carries **ONE** mark.

08X01=08

1. Define unit.
2. Define capillarity.
3. What is SI unit of power?
4. Define Hooke's law.
5. Name any one example of conservation of energy.
6. Define energy.
7. Define specific heat of a gas.
8. Define internal energy.

**PART – B**

- Instructions: 1. Answer **ALL** questions.  
2. Each question carries **THREE** marks.

04X03=12

9(a). Explain Lami's theorem.

(OR)

9(b). Explain renewable and non-renewable energy sources with example.

10(a). Explain projectile motion with example.

(OR)

10(b). Explain Boyle's law and its limitations.

11(a). Show that  $PE = mgh$

(OR)

11(b). Explain law of conservation of energy in the case of simple pendulum.

12(a). Explain first law of thermodynamics and list applications of it.

(OR)

12(b). Explain Boyle's law and its limitations.

## PART – C

- Instructions: 1. Answer **ALL** questions.  
2. Each question carries **FIVE** marks.

04X05 = 20

13(a). Develop expressions for magnitude and direction of resultant of two vectors using parallelogram law of vectors.

(OR)

13(b). Develop expression for kinetic energy of a body of mass 'm' moving with a velocity 'v'.

14(a). Develop a relation between linear velocity and angular velocity.

(OR)

14(b). apply first law of thermodynamics to isothermal and adiabatic processes.

15(a). Apply law of conservation of energy in the case of freely falling body.

(OR)

15(b). Explain Work-Energy theorem and develop the relation.

16(a). develop ideal gas equation

(OR)

16(b). Explain principle of bimetallic strip and apply it to electric water heater thermostat

## SC-104 - GENERAL ENGINEERING CHEMISTRY

Course Title	General Engineering Chemistry	Course Code	SC-104
Semester	I	Course Group	Foundation
Teaching Scheme in Periods (L:T:P)	4:1:0	Credits	3
Methodology	Lecture +Tutorial	Total Contact Periods	75
CIE	60 Marks	SEE	40 Marks

**Prerequisite:** Basic knowledge of chemistry in secondary education.

**Course Objectives:** After studying this course, the student will be able to understand and appreciate the role of Chemistry and environmental studies in different spheres of industries.

**Course Outcome:** On successful completion of the course, the students will have ability to attain below Course Outcomes (CO):

CO1	Understand and explain the concept of atomic structure, chemical bonding, oxidation, reduction and oxidation number and apply the knowledge to solve engineering problems.
CO2	Understand and explain concept of mole, molarity, normality and colloids and apply the knowledge in various engineering areas.
CO3	Understand and explain the different theories of acids and bases, concept of pH, buffer action and apply the knowledge to solve engineering problems.
CO4	Understand the concept of Ecosystem, Biodiversity, Green Chemistry and Management of e-waste and take measures to support sustainable development.
CO5	Understand the concept of hardness and degree of hardness of water and apply the relevant water treatment methods to solve domestic and industrial problems.
CO6	Understand the concept of electrolysis, applications of electrolysis, Faraday's Laws of Electrolysis and apply the knowledge in extraction and purification of metals used for domestic and industrial purpose.

CO	PO1	PO2	PO3	PO4	PO5	PO6	PO7
CO1	3	1	-	-	-	-	2
CO2	3	1	-	-	1	-	2
CO3	3	1	-	-	-	-	2
CO4	3	-	-	-	3	-	3
CO5	3	1	-	-	1	-	2
CO6	3	1	-	-	-	-	2

## COURSE CONTENTS

### **UNIT-I: Fundamentals of Chemistry**

**13 Periods**

**Atomic Structure:** Introduction – Atomic number – Mass number- Isotopes and Isobars - Bohr's Atomic Theory - Orbitals - Shapes of s, p and d orbitals – Aufbau principle - Hund's rule - Pauli's exclusion principle - Electronic configuration of elements

**Chemical Bonding:** Introduction – Electronic theory of valency - Types of chemical bonds - Ionic, Covalent, Co-ordinate covalent, Metallic and Hydrogen bonds with examples - Properties of Ionic and Covalent compounds - Types of Hydrogen bonds – Effect of hydrogen bonding on physical properties.

**Oxidation-Reduction:** Electronic concept of Oxidation, Reduction, Oxidation Number - Calculations.

### **UNIT-II: Solutions and Colloids**

**12 Periods**

Introduction - Solution – Solubility - Classification of solutions based on physical state- Atomic weight - Molecular weight ,Equivalent weight - Mole concept – Molarity – Normality - Numerical problems on mole, molarity and normality – Colloids - Types of colloids- Lyophilic and Lyophobic colloids - Protective Colloids - Gold number - Properties of Colloids - Industrial applications of colloids.

### **UNIT-III: Acids and Bases**

**13 Periods**

Introduction - Theories of acids and bases and limitations - Arrhenius theory - Bronsted - Lowry theory - Lewis acid base theory - Ionic product of water - pH and related numerical problems - Buffer solutions- buffer action - Applications of buffer solution - Ostwald's theory of indicators.

### **UNIT-IV: Environmental Science**

**12Periods**

Introduction - Environment -Scope and importance of environmental studies- Important terms -Concept of ecosystem - Producers, consumers and decomposers - Food chain - Food web - Carbon and nitrogen cycles - Biodiversity, definition and threats to Biodiversity- Forest resources- Deforestation – Green Chemistry – e-waste – Management of e-waste.

## **UNIT-V: Water Technology**

**13 Periods**

Introduction -Soft and hard water - Causes of hardness – Types of hardness - Disadvantages of hard water using in industries - Degree of hardness - Softening methods - Permutit process - Ion exchange process - Drinking water - Municipal treatment of water for drinking purpose – Osmosis - Reverse Osmosis - Advantages of Reverse osmosis – Desalination by Electro dialysis – Defluoridation – Nalgonda Technique.

## **UNIT-VI: Electrochemistry:**

**12 Periods**

Conductors, insulators, electrolytes – Types of electrolytes - Arrhenius theory of electrolytic dissociation - Electrolysis – Electrolysis of fused NaCl and aqueous NaCl – Applications of electrolysis - Faraday's laws of electrolysis- Numerical problems.

### **Reference Books:**

1. Engineering chemistry – Jain & Jain – Dhanpat Rai Publishing Company.
2. A Text book of Engineering Chemistry – S.S.Dara – S.Chand Publications.
3. Environmental Studies – A.K.De.
4. Environmental Studies, R. Rajagopalan, 2nd Edition, 2011, Oxford University Press
5. Intermediate Chemistry I and II – Telugu Academy TS
6. Engineering chemistry – Prasanta Rath, B. Ramadevi, Ch. Venkataramana Reddy& Subhendu Chakroborty – CENGAGE

### **E - learning links:**

1. <https://iupac.org/>
2. <https://www.khanacademy.org/>
3. [www.nptel.ac.in](http://www.nptel.ac.in)
4. [www.chemguide.co.uk](http://www.chemguide.co.uk)
5. [www.visionlearning.com](http://www.visionlearning.com)

### **Specific Learning Outcomes**

**Upon completion of the course, the student will have ability to**

## **UNIT- I: FUNDAMENTALS OF CHEMISTRY**

- 1.1 Explain the concept of atomic number, mass number, isotopes and isobars
- 1.2 State the postulates of Bohr's atomic theory and its limitations
- 1.3 Define Orbital.
- 1.4 Draw and explain the shapes of s, p and d orbitals.

- 1.5 Distinguish between Orbit and Orbital
- 1.6 Make use of 1. Aufbau principle, 2. Hund's rule and 3. Pauli's exclusion principle in writing electronic configuration of elements.
- 1.7 Write the electronic configuration of elements up to atomic number 30
- 1.8 Define chemical bond.
- 1.9 Write the Postulates of Electronic theory of valency.
- 1.10 List the types of chemical bonds viz., Ionic, Covalent, Co-ordinate covalent, Metallic and Hydrogen bond.
- 1.11 Define ionic bond and explain the Ionic bond formation in NaCl, MgO, CaCl<sub>2</sub>, Na<sub>2</sub>O, K<sub>2</sub>O.
- 1.12 List and explain the properties of ionic compounds.
- 1.13 Explain covalent bond formation in Hydrogen, Oxygen, Nitrogen, Ammonia, Methane, Ethylene, and Acetylene molecules using Lewis Dot Method.
- 1.14 List and explain the properties of covalent compounds.
- 1.15 Compare the properties of ionic compounds and covalent compounds.
- 1.16 Define metallic bond and explain with free electron theory/ electron sea model.
- 1.17 Define hydrogen bond
- 1.18 Explain inter molecular hydrogen bonding in HF, H<sub>2</sub>O, NH<sub>3</sub>
- 1.19 Explain inter and intra molecular hydrogen bonding in Salicylaldehyde and Nitrophenol.
- 1.20 Explain the effect of hydrogen bonding on the boiling point.
- 1.21 Explain the effect of hydrogen bonding on solubility of alcohols
- 1.22 Understand the electronic concept of oxidation, reduction and redox reaction.
- 1.23 Define oxidation number
- 1.24 List the rules for calculation of oxidation number.
- 1.25 Apply the rules to calculate the oxidation number.

## **UNIT-II: SOLUTIONS AND COLLOIDS**

- 2.1 Define the terms 1.Solution, 2.Solute and 3.Solvent.
- 2.2 Define solubility.
- 2.3 Explain the factors effecting solubility.
- 2.4 Define aqueous solution and alcoholic solution.
- 2.5 Compare unsaturated, saturated and super saturated solutions.

- 2.6 Classify the solutions based on the physical state of solute and solvent.
- 2.7 Define atomic weight, molecular weight and equivalent weight.
- 2.8 Calculate the molecular weight and the equivalent weights of acids, bases and salts.
- 2.9 Define mole.
- 2.10 Explain mole concept and solve the numerical problems.
- 2.11 Define and explain molarity and normality.
- 2.12 Derive the relationship between molarity to normality.
- 2.13 Solve numerical problems on molarity and normality of a solution and mixture of solutions.
- 2.14 Define and explain colloids, dispersed phase and dispersion medium with examples.
- 2.15 List the types of colloids with examples.
- 2.16 Distinguish between Lyophilic Colloid and Lyophobic Colloid.
- 2.17 Understand the Protective Colloids and Gold number. (Elementary level)
- 2.18 Explain the properties of colloids: Tyndall effect, Brownian movement and Coagulation.
- 2.19 State and explain the industrial applications of colloids.

### **UNIT-III: ACIDS AND BASES**

- 3.1 Explain Arrhenius theory of acids and bases.
- 3.2 State the limitations of Arrhenius theory of acids and bases
- 3.3 Explain Bronsted - Lowry theory of acids and bases.
- 3.4 State the limitations of Bronsted - Lowry theory of acids and bases.
- 3.5 Explain Lewis theory of acids and bases.
- 3.6 List out the types of Lewis acids and bases.
- 3.7 State the limitations of Lewis theory of acids and bases.
- 3.8 Explain the ionic product of water and solve the problems.
- 3.9 Define pH and explain Sorenson's pH scale.
- 3.10 Solve the numerical problems on pH (Strong acids and bases).
- 3.11 Define buffer solutions and give examples of acidic and basic buffers.
- 3.12 State the applications of buffer solutions.
- 3.13 Explain the buffer action of acidic (acetate buffer) and basic (ammonium buffer) buffers.
- 3.14 Explain the Ostwald's theory of indicators with phenolphthalein and methyl orange indicators as an example.

## **UNIT-IV: ENVIRONMENTAL SCIENCE**

4.1 Define the term environment

4.2 Explain the importance of the following

1) Lithosphere, 2) Hydrosphere, 3) Atmosphere, 4) Biosphere,

4.3 Define and understand the following terms

i) Pollutant, ii) Contaminant iii) Pollution, iv) Receptor, v) Sink,  
vi) Particulates, vii) Threshold limit value (TLV), viii) Dissolved oxygen  
(DO), ix) BOD and x) COD

4.4 Define Ecosystem. Understand the biotic and the abiotic components of ecosystem.

4.5 Define and explain the following biotic components with examples

1) Producers, 2) Consumers and 3) Decomposers

4.6 Explain the food chain of land, aquatic and forest.

4.7 Explain the Food web.

4.8 Understand the Carbon and Nitrogen cycles.

4.9 Define and explain biodiversity

4.10 Explain the threats to biodiversity.

4.11 Explain conservation of biodiversity.

4.12 Describe the forest and list the uses of forests.

4.13 Define the deforestation and explain the causes, effects and control of deforestation.

4.14 Understand the concept of Green Chemistry – Its principles and benefits.

4.15 Define e-waste

4.16 Explain the effect of e-waste on environment.

4.17 State the effects of chemicals released from e-waste on human beings.

4.18 Explain the management of e-waste.

4.19 Understand and explain the advantage of recycling of e-waste.

## **UNIT V: WATER TECHNOLOGY**

5.1 State the various sources of water.

5.2 Define the terms soft water and hard water with examples

5.3 Define hardness of water.

5.4 Explain temporary and permanent hardness of water.

5.5 List the usual chemical compounds causing hardness (with Formulae)

5.6 Explain the disadvantages of using hard water in industries.

- 5.7 Define Degree of hardness, units of hardness in ppm , mg/L and numerical problems related to hardness.
- 5.8 Explain the methods of softening of hard water:
- a) Removal of temporary hardness by i) Boiling ii) Clark's Method
  - b) Removal of total hardness by i) Permutit process ii) Ion-Exchange process.
- 5.9 List the essential qualities of drinking water.
- 5.10 Explain Municipal treatment of water for drinking purpose.
- 5.11 Define Osmosis and Reverse Osmosis (RO).
- 5.12 List the applications and advantages of RO.
- 5.13 Explain the process of desalination of sea water by Electro dialysis.
- 5.14 Explain the process of defluoridation by using Nalgonda Technique.

## **UNIT VI: ELECTROCHEMISTRY**

- 6.1 Define the terms 1. Conductor, 2. Insulator, 3. Electrolyte and 4. Non-electrolyte
- 6.2 Types of electrolytes - strong and weak electrolytes with examples.
- 6.3 Distinguish between metallic conductors and Electrolytic conductors.
- 6.4 Explain the Arrhenius theory of electrolytic dissociation
- 6.5 Define electrolysis.
- 6.6 Explain the electrolysis of fused NaCl and aqueous NaCl (Nelson Cell).
- 6.7 Explain the applications of Electrolysis - Electrolytic refining of metal (Copper)  
- Electroplating.
- 6.8 Explain Faraday's laws of electrolysis
- 6.9 Define chemical equivalent, electrochemical equivalent.
- 6.10 Know the relationship between chemical equivalent and electrochemical equivalent
- 6.11 Solve the numerical problems based on Faraday's laws of electrolysis

## Blue Print

### MID SEM-I EXAM

S.No	Unit Name	R	U	A	Remarks
1	Unit-I	1, 2	5(a) 5(b)	7(a) 7(b)	
2	Unit-II	3, 4	6(a) 6(b)	8(a) 8(b)	
Total Questions		4	4	4	
<b>MID SEM –II EXAM</b>					
S.No	Unit Name	R	U	A	Remarks
1	Unit-III	1, 2	5(a) 5(b)	7(a) 7(b)	
2	Unit-IV	3, 4	6(a) 6(b)	8(a) 8(b)	
Total Questions		4	4	4	

### Semester End Examination

Sl No	Unit No.	Questions to be set for SEE			Remarks		
		R	U	A			
1	I	4	1	9(a)	13(a)		
2	II			9(b)	13(b)		
3	III		2	10(a)	14(a)		
4	IV			10(b)	14(b)		
5	V		3	5, 6	11(a)	15(a)	
					11(b)	15(b)	
6	VI	7,8		12(a)	16(a)		
				12(b)	16(b)		
Total Questions		8	8	8			

Legend:	Remembering (R)	1 Mark
	Understanding (U)	3 Marks
	Application (A)	5 Marks

**BOARD DIPLOMA EXAMINATIONS (C21)**  
**I SEMESTER, MIDSEM – I**  
**SC-104 - GENERAL ENGINEERING CHEMISTRY**

**Time: 1 Hour**

**Max. Marks: 20**

---

**PART – A**

Instructions: Answer **all** questions. Each question carries **one** mark.  
marks

4 X 1 = 4

1. State Hund's rule.
2. Write the electronic configuration of Cr.
3. Define mole.
4. What are colloids?

**PART – B**

Instructions: Answer **the following** questions. Each question carries **three** marks

2 x 3 = 6 Marks

5. a. Draw the shapes of s and d orbitals.  
(OR)  
b. Explain the covalent bond formation in Nitrogen molecule by Lewis dot method.
6. a. Classify solutions based on their physical state.  
(OR)  
b. Compare any three properties of lyophilic and lyophobic colloids.

**PART – C**

Instructions: Answer **the following** questions. Each question carries **five** marks

2 x 5 = 10 Marks

7. a. Explain the effect of hydrogen bonding on boiling point with examples.  
(OR)  
b. What is oxidation number? Find the oxidation number of 'S' in  $\text{H}_2\text{SO}_4$  and 'Mn' in  $\text{KMnO}_4$ .
8. a. Define molarity. Find the weight of  $\text{H}_2\text{SO}_4$  required to prepare 400 ml of 0.5M solution.  
(OR)  
b. Define normality. Calculate the normality of 500 ml solution containing 0.53 grams of  $\text{Na}_2\text{CO}_3$ .

**BOARD DIPLOMA EXAMINATIONS (C21)**  
**I SEMESTER, MIDSEM – II**  
**SC-104 - GENERAL ENGINEERING CHEMISTRY**

**Time: 1 Hour**

**Max. Marks: 20**

---

**PART – A**

Instructions: i. Answer **all** questions. Each question carries **one** mark.

4 X 1 = 4 marks

1. What is conjugate acid base pair?
2. Define ionic product of water.
3. Define an ecosystem.
4. What is threshold limit value?

**PART – B**

Instructions: Answer **the following** questions. Each question carries **three** marks

2 x 3 = 6 Marks

5. a. What are the limitations of Arrhenius theory of acids and bases?  
(OR)  
b. Explain the neutralization according to Lewis theory of acids and bases with an example.
6. a. Explain the terms producers, consumers and decomposers with example.  
(OR)  
b. Explain the aquatic food chain.

**PART – C**

Instructions: Answer **the following** questions. Each question carries **five** marks

2 x 5 = 10 Marks

7. a. Define pH. Find the pH of 0.5M NaOH solution.  
(OR)  
b. What are buffer solutions? State the applications of buffer solutions.
8. a. What is Biodiversity and how to conserve the Biodiversity.  
(OR)  
b. What is deforestation? What are its consequences?

**BOARD DIPLOMA EXAMINATIONS (C21)**  
**I SEMESTER END EXAMINATION**  
**SC-104 - GENERAL ENGINEERING CHEMISTRY**

**Time: 2 Hours**

**Max. Marks: 40**

---

**PART-A**

Instructions: Answer **all** questions. Each question carries **one** mark.

8 X 1 = 8 marks

1. Define atomic mass number.
2. What is biodiversity?
3. Define degree of hardness of water.
4. What are buffer solutions?
5. Define soft water and hard water.
6. Name the salts responsible for temporary hardness of water.
7. Define the terms conductor and insulator.
8. What is an electrolyte?

**PART – B**

Instructions: Answer **the following** questions. Each question carries **three** marks

4 x 3 = 12 Marks

9. a. State and explain Hund' rule.  
or  
b. Write any six essential qualities of drinking water.
10. a. Explain the terms producers, consumers and decomposers with example.  
or  
b. What are strong and weak electrolytes? Give examples.
11. a. Define reverse osmosis and state its advantages.  
or  
b. Compare temporary and permanent hardness of water.
12. a. Distinguish between metallic and electrolytic conductors.  
Or  
b. State Faraday's Laws of electrolysis.

PART – C

Instructions: Answer **the following** questions. Each question carries **five** marks 4 x 5 =20  
Marks

13. a. Find the molarity and normality of the two litres of solution containing 10.6 grams of  $\text{Na}_2\text{CO}_3$ .

or

b. Calculate the temporary and permanent hardness of water containing the following salts per litre

i.  $\text{Ca}(\text{HCO}_3)_2 = 32.4 \text{ mg}$ , ii.  $\text{Mg}(\text{HCO}_3)_2 = 29.2 \text{ mg}$ , iii.  $\text{CaSO}_4 = 13.6 \text{ mg}$ , iv.  $\text{MgCl}_2 = 19 \text{ mg}$

14. a. Explain Lewis theory of acids and bases.

or

b. Explain the process of electrolysis of fused  $\text{NaCl}$ .

15. a. Explain the permutit process of softening of hard water with a neat diagram.

or

b. What are the disadvantages of using hard water in industries?

16. a. Explain the process of electrolytic refining of copper.

Or

b. Calculate the weight of  $\text{Al}$  deposited on the cathode if 0.5 amperes of electric current is passed through  $\text{AlCl}_3$  solution for 1 hour.

## EC-105 - Basic Electrical & Electronics Engineering

Course Title :	Basic Electrical & Electronics Engineering	Course Code	EC-105
Semester	I	Course Group	Core
Teaching Scheme in Periods(L:T:P)	4:1:0	Credits	3
Methodology	Lecture + Assignments	Total Contact Hours	75 Periods
CIE	60 Marks	SEE	40 Marks

### Pre requisites

This course requires the basic knowledge of Basic Physics and Mathematics at Secondary school level

### Course Outcomes:

Upon completion of the course the student should be able to achieve the following outcomes

CO1 :	Interpret the Basic principles of electricity
CO2 :	Classify Resistors, Inductors and Capacitors, also explain their applications and specifications.
CO3 :	Explain the working of Diodes and special Semiconductor devices.
CO4 :	Analyze the working of Transistor in different regions and configurations.
CO5 :	Explain Transistor biasing and Stabilization techniques.
CO6 :	Analyze the working of FETs and MOSFETs.

CO	PO1	PO2	PO3	PO4	PO5	PO6	PO7
CO1	3	1	1	-	1	1	3
CO2	3	3	3	2	3	3	3
CO3	3	2	3	3	2	3	3
CO4	3	1	3	3	1	3	3
CO5	3	1	2	1	2	1	3
CO6	3	1	3	3	3	2	3

## Course Content

### UNIT 1 – Basic principles of electricity

**Duration: 12 Periods**

Define (i) electric current (ii) EMF (iii) voltage, concept of resistance to flow of electrons- Deduce the relation  $R = \frac{\rho l}{A}$ , specific resistance, simple problems based on specific resistance- effects of temperature on resistance- expression for resistance at any temperature as  $R_t = R_0(1 + \alpha_0 t)$ - Temperature co-efficient at zero  $0^\circ\text{C}$  and any temperature  $t^\circ\text{C}$  -solve problems based on the  $R_t = R_0(1 + \alpha_0 t)$  &  $\alpha_t = \frac{\alpha_0}{(1 + \alpha_0 t)}$ . expression for equivalent resistance when resistors are connected in series and parallel-problems on series circuits and parallel circuits-work, Power and Energy-Joule's Law -concept of sine wave and define the important terms. Write different forms of emf equation -simple problems to calculate Amplitude, frequency and Time Period -Define the terms Average value, R.M.S. value, Form Factor and Peak Factor for sine wave- terms phase and phase difference- concept of Leading, lagging and in phase components with the help of waveforms.

### UNIT 2– Classification of Resistors, Inductors and Capacitors

**Duration: 13 Periods**

Types of resistors- specifications of a resistor, and state their importance- necessity of preferred- values in resistor- Colour Code (4band and 5 band)-common faults in resistors- wire wound Resistors-applications of Wire wound Resistor- Variable resistors-European and US standard symbols of Potentiometers and Presets-specifications and applications of LDR-principle of operation of VDR-specifications of inductors-applications of A.F. and R.F chokes- common faults in inductors- different types of capacitors-specifications of a capacitor and state their importance- different markings on the a) Electrolytic capacitors b) Ceramic and Plastic capacitors (Value, Polarization, Voltage, Tolerance, temperature rating)- Reading of capacitor value and tolerance by 1. Colour code 2. Value printed-applications of Paper, Mica, Glass, Polyester, Polystyrene, Ceramic, Electrolytic capacitors- losses and common faults in capacitors.

### **UNIT 3 : Explain the working of Diodes and special Semiconductor devices**

**Duration: 12 Periods**

P-type and N-type semiconductors - PN Junction Diode with no bias - forward bias and reverse bias of PN diode - Volt-Ampere (V-I) characteristics of PN Diode - applications of PN Diode -Working principle of varactor diode- characteristics of Varactor Diode- constructional details of photo diode-characteristics of photo diode-characteristics of photo transistor-principle of photovoltaic cell. Working principle of LCD-types of LCD displays-merits and demerits of LCD Displays-applications of LCD.

### **UNIT4 –. Understand the working of Transistor**

**Duration: 13 Periods**

Formation of Transistor-working of PNP and NPN Transistors-the input/output characteristics of CB, CE and CC configurations-Interpret the regions of operation of a transistor- relate the alpha, beta and gamma Factors- important specifications and applications of BJT-expression for collector current in CE configuration-performance characteristics of CE, CB and CC Configurations-Transistor as an amplifier- working principle of UJT with its equivalent circuit- UJT characteristics- - applications of UJT-.

### **UNIT 5 : Understand Transistor biasing and Stabilization techniques**

**Duration: 12 Periods**

Concept of DC and AC load line-selection of operating point on DC load line with waveforms-factors affecting the Q-point- thermal runaway-need for proper biasing in amplifier circuits- types of biasing circuits-stabilization in amplifier circuits-various stability factors ( $S$ ,  $S\beta$ ,  $SV_{BE}$ )-expression for stability factor in CE configuration-fixed bias circuit-collector to base resistor method of biasing- self-bias circuit-CE amplifier and explain the function of each component.

## UNIT 6 : Understand the working of FETs and MOSFETs.

**Duration: 13 Periods**

different types of FETs and draw their symbols-construction and principle of operation of n-channel JFET-drain characteristics of JFET-mutual characteristics of JFET-parameters of JFET and obtain the relation among them-specifications and applications of JFET-merits of JFET over BJT-construction and principle of operation of depletion type MOSFET-construction and principle of operation of enhancement type MOSFET-Compare JFET and MOSFET-principle of operation of CMOSFET.

### Recommended Books

- |   |    |                           |
|---|----|---------------------------|
| 1. Basic Electrical Engineering                           | By | V.K.Mehatha               |
| 2. Electrical Technology Volume 1                         | By | BL Theraja                |
| 3. Electronic Devices and Circuits                        | By | David A.BellPrentice hall |
| 4. Hand book of components for Electronics<br>McGrawhills | By | Charles A. Harper         |

### Specific Learning Outcomes

#### 1.0 Basic principles of electricity

- 1.1 Define (i) electric current (ii) EMF (iii) voltage
- 1.2 Explain the concept of resistance to flow of electrons.
- 1.3 Deduce the relation  $R = (\rho l) / a$
- 1.4 Define specific resistance.
- 1.5 Solve simple problems based on specific resistance.
- 1.6 Explain the effects of temperature on resistance
- 1.7 Develop the expression for resistance at any temperature as  $R_t = R_o(1 + \alpha_o t)$
- 1.8 Define Temperature co-efficient at zero  $0^\circ\text{C}$  and any temperature  $t^\circ\text{C}$
- 1.9 Solve problems based on the  $R_t = R_o(1 + \alpha_o t)$  &  $\alpha_t = \alpha_o / (1 + \alpha_o t)$ .
- 1.10 Derive the expression for equivalent resistance when resistors are connected in series and parallel.
- 1.11 Solve problems on series circuits and parallel circuits.
- 1.12 Define work, Power and Energy.
- 1.13 Define Joule's Law
- 1.14 Explain the concept of sine wave and define the important terms.
- 1.15 Write different forms of emf equation

- 1.16 Solve simple problems to calculate Amplitude, frequency and Time Period
- 1.17 Define the terms Average value, R.M.S. value, Form Factor and Peak Factor for sine wave.
- 1.18 Explain the terms phase and phase difference.
- 1.19 Explain the concept of Leading, lagging and in phase components with the help of waveforms.

## **2.0 Classification of Resistors, Inductors and Capacitors**

- 2.1 Classify types of resistors.
- 2.2 List the specifications of a resistor, and state their importance.
- 2.3 Explain the necessity of preferred values in resistor.
- 2.4 Identify Resistance Value by using Colour Code (4band and 5 band).
- 2.5 List the common faults in resistors.
- 2.6 Classify wire wound Resistors.
- 2.7 List applications of Wire wound Resistor.
- 2.8 List the two types of Variable resistors.
- 2.9 Draw the European and US standard symbols of Potentiometers and Presets.
- 2.10 List important specifications and applications of LDR.
- 2.11 Explain principle of operation of VDR.
- 2.12 List the specifications of inductors.
- 2.13 List the applications of A.F. and R.F chokes.
- 2.14 List the common faults in inductors.
- 2.15 Classify the different types of capacitors.
- 2.16 List the specifications of a capacitor and state their importance.
- 2.17 Explain different markings on the a) Electrolytic capacitors b) Ceramic and Plastic capacitors (Value, Polarization, Voltage, Tolerance, temperature rating).
- 2.18 Explain Reading of capacitor value and tolerance by 1. Colour code 2. Value printed.
- 2.19 Mention the applications of Paper, Mica, Glass, Polyester, Ceramic, Electrolytic capacitors.
- 2.20 Mention the losses and common faults in capacitor

## **3.0 Explain the working of special Semiconductor devices**

- 3.1 Explain extrinsic semiconductors - P-type and N-type semiconductors.
- 3.2 Explain PN Junction Diode with no bias.

- 3.3 Explain forward bias and reverse bias of PN diode
- 3.4 Explain Volt-Ampere (V-I) characteristics of PN Diode.
- 3.5 List the applications of PN Diode.
- 3.6 Explain the working principle of varactor diode.
- 3.7 Draw the characteristics of Varactor Diode.
- 3.8 List the application of varactor diode
- 3.9 Explain constructional details of photo diode.
- 3.10 Draw and explain the characteristics of photo diode.
- 3.11 Draw and explain the characteristics of photo transistor.
- 3.12 Explain the principle of photovoltaic cell.
- 3.13 Explain the working principle of LCD
- 3.14 Mention the types of LCD displays
- 3.15 List the merits and demerits of LCD Displays
- 3.16 List the applications of LCD.

#### **4.0 Understand the working of Transistor.**

- 4.1 Explain the formation of Transistor.
- 4.2 Explain the working of PNP and NPN Transistors.
- 4.3 Sketch the input/output characteristics of CB, CE and CC configurations.
- 4.4 Interpret the regions of operation of a transistor.
- 4.5 Derive and relate the alpha, beta and gamma Factors.
- 4.6 List important specifications and applications of BJT.
- 4.7 Derive the expression for collector current in CE configuration.
- 4.8 Compare the performance characteristics of CE, CB and CC Configurations
- 4.9 Explain how Transistor works as an amplifier.
- 4.10 Explain the working principle of UJT with its equivalent circuit
- 4.11 Draw and explain UJT characteristics.
- 4.12 List applications of UJT.

#### **5.0 Understand Transistor biasing and Stabilization techniques**

- 5.1 Explain the concept of DC and AC load line.
- 5.2 Explain the selection of operating point on DC load line with waveforms.
- 5.3 List the factors affecting the Q-point.
- 5.4 Explain thermal runaway

- 5.5 State the need for proper biasing in amplifier circuits.
- 5.6 List the types of biasing circuits.
- 5.7 Define stabilization in amplifier circuits.
- 5.8 Define the various stability factors (S,  $S\beta$ , SVBE)
- 5.9 Derive an expression for stability factor in CE configuration.
- 5.10 Explain the fixed bias circuit.
- 5.11 Explain the collector to base resistor method of biasing.
- 5.12 Explain the self-bias circuit.
- 5.13 Draw a practical CE amplifier and explain the function of each component.

## **6.0 Understand the working of FETs and MOSFETs.**

- 6.1 Classify the different types of FETs and draw their symbols.
- 6.2 Explain the construction and principle of operation of n-channel JFET.
- 6.3 Draw and explain the drain characteristics of JFET
- 6.4 Draw and explain the mutual characteristics of JFET.
- 6.5 Define the parameters of JFET and obtain the relation among them.
- 6.6 List the important specifications and applications of JFET.
- 6.7 List the merits of JFET over BJT.
- 6.8 Explain the construction and principle of operation of depletion type MOSFET.
- 6.9 Explain the construction and principle of operation of enhancement type MOSFET.
- 6.10 Compare JFET and MOSFET.
- 6.11 Explain the principle of operation of CMOSFET.

### **Suggested Student Activities**

1. Student visits Library to refer to Manual of Electronic components to find their specifications
2. Student inspects the available equipment in the Lab to identify the components
3. Visit nearby Industry to familiarize with fabrication techniques
4. Analyze the connections in the UPS available in the Institution facility
5. Quiz

6. Group discussion
7. Surprise tests

**Suggested E-Learning resources**

1. <http://electrical4u.com/>
2. [www.electronics-tutorials.ws](http://www.electronics-tutorials.ws)
3. [www.nptel.ac.in](http://www.nptel.ac.in)

**MID SEM EXAMINATIONS**

S.No	Unit Name	MID SEM-I EXAM			
		R	U	A	Remarks
1	Unit-I	1, 2	5(a) 5(b)	7(a) 7(b)	
2	Unit-II	3, 4	6(a) 6(b)	8(a) 8(b)	
	Total Questions	4	4	4	
S.No	Unit Name	MID SEM-II EXAM			
		R	U	A	Remarks
1	Unit-III	1, 2	5(a) 5(b)	7(a) 7(b)	
2	Unit-IV	3, 4	6(a) 6(b)	8(a) 8(b)	
	Total Questions	4	4	4	

**SEMESTER END EXAMINATION**

Sl No	Unit No.	Questions to be set for SEE			Remarks		
		R(1 Mark)	U(3 Marks)	A(5 Marks)			
1	I	4	1	9(a)	13(a)		
2	II			2	10(a)	14(a)	
3	III		3		5, 6	9(b)	13(b)
4	IV			11(a)		15(a)	
5	V			11(b)		15(b)	
6	VI		7,8	10(b)	14(b)		
				12(a)	16(a)		
				12(b)	16(b)		
Total Questions		8		8	8		

**BOARD DIPLOMA EXAMINATIONS (C21)**  
**I SEMESTER, MIDSEM – I**  
**EC-105 BASICS OF ELECTRICAL & ELECTRONICS ENGINEERING**

**Time: 1 Hour**

**Max. Marks: 20**

**PART – A**

Instructions: Answer **all** questions. Each question carries **one** mark.  
marks

4 X 1 = 4

1. Define specific resistance.
2. Define work and power.
3. List any 2 important specifications of resistors.
4. Mention the losses in capacitors.

**PART – B**

Instructions: Answer **the following** questions. Each question carries **three** marks

2 x 3 = 6 Marks

5a. Calculate the time period and frequency of a sine wave of voltage  $v = 20 \sin(500\pi t)$  volts.

**(OR)**

b. Derive the expression for equivalent resistance when resistances are connected in series.

6a. List the important applications of LDR.

**(OR)**

b. List the common faults in inductors.

**PART – C**

Instructions: Answer **the following** questions. Each question carries **five** marks

1 x 5 = 10 Marks

7a. Derive the expression for resistance at any temperature as  $R_t = R_o(1 + \alpha_0 t)$ .

**(OR)**

b. Explain the concept of phase leading and phase lagging with necessary waveforms.

8a. Classify different types of capacitors.

**(OR)**

b. List the specifications of inductors.

**BOARD DIPLOMA EXAMINATIONS (C21)**  
**I SEMESTER, MIDSEM – II**  
**EC-105 BASICS OF ELECTRICAL & ELECTRONICS ENGINEERING**

**Time: 1 Hour**

**Max. Marks: 20**

**PART – A**

Instructions: i. Answer **all** questions. Each question carries **one** mark.

4 X 1 = 4 marks

1. What is N-type semiconductor?
2. What is doping?
3. Define alpha of a transistor.
4. Write the relation between alpha and beta of a transistor.

**PART – B**

Instructions: Answer **the following** questions. Each question carries **three** marks

3x 3 =6 Marks

5a. Explain the working of PN diode without bias.

**(OR)**

b. Explain the working principle of LCD.

6a. Derive the expression for collector current in CE configuration.

**(OR)**

b. . Explain the working of transistor as amplifier.

**PART – C**

Instructions: Answer **the following** questions. Each question carries **five** marks

2 x 5 =10 Marks

9a. Explain the V-I characteristics of UJT.

**(OR)**

b. Explain the constructional details of photo diode.

10a. Compare the performance characteristics of CB,CE and CC configuration.

**(OR)**

b. Explain the working of NPN transistor.

**BOARD DIPLOMA EXAMINATIONS (C21)**  
**I SEMESTER END EXAMINATION**  
**EC-105 BASICS OF ELECTRICAL AND ELECTRONICS ENGINEERING**  
**Time: 2 Hours** **Max. Marks: 40**

---

**PART-A**

Instructions: Answer **all** questions. Each question carries **one** mark.  
marks

8 X 1 = 8

1. Define specific resistance.
2. What is an RF choke?
3. Define beta of a transistor.
4. Draw the symbols of Varactor diode and UJT.
5. List the applications of LCD.
6. List the merits of LCD displays.
7. Draw the symbol of JFET and MOSFET.
8. What are the parameters of JFET?

**PART – B**

Instructions: Answer **the following** questions. Each question carries **three** marks 4 x 3 =12  
Marks

9 a. Derive the expression for equivalent resistance when resistances are connected in series.

**(OR)**

b. Explain the selection of operating point on DC load line.

10 a. List the common faults in inductors.

**(OR)**

b. List the important applications of JFET.

11a. State the need for proper biasing in amplifier circuits.

**OR**

b. List the factors affecting the Q point.

12a. List the merits of JFET over BJT.

**OR**

b. Draw and explain the mutual characteristics of JFET.

**PART – C**

Instructions: Answer **the following** questions. Each question carries **five** marks 4 x 5 =20  
Marks

13a. List the specifications of capacitor and explain their importance.

**(OR)**

b. Explain the drain characteristics of JFET.

14 a. Explain the working principle of Varactor diode.

(OR)

b. Explain the working principle of enhancement type of MOSFET.

15 a. Explain the concept of DC and AC load line.

(OR)

b. Explain the self- bias circuit.

16 a. Explain the drain characteristics of n-channel JFET

(OR)

b. List any 5 merits of JFET over BJT

## ME-106 BASIC ENGINEERING DRAWING

(This Course is Common to all programs of Diploma in Engineering offered by the State Board of Technical Education, Hyderabad, Telangana State)

Course Title :	Basic Engineering Drawing	Course Code	ME-106
Semester	I	Course Group	Core
Teaching Scheme in Pds (L :P)	1:0:2	Credits	1.5
Methodology	Lecture + Practice	Total Contact Pds:	45
CIE	60 Marks	SEE	40 Marks

**Prerequisites:** No prerequisites are required to learn this course.

### Course Objectives

The Course is aimed at developing basic drawing skills so as to enable them to use these skills in the preparation of engineering drawings, their reading and interpretation.

### Course Outcomes

*Upon completion of the subject the student shall be able to*

<b>CO1</b>	Recognize the importance of Engineering Drawing and usage of the drawing instruments.
<b>CO2</b>	Practice free hand lettering & numbering in different styles.
<b>CO3</b>	Recognize the importance of Dimensioning and Acquiring the knowledge of different methods of dimensioning systems.
<b>CO4</b>	Appreciate the usage of engineering curves such as tangent lines, tangent arcs, parabola, hyperbola, ellipse, involute, cycloid and helix in various engineering applications and draw the above said curves
<b>CO5</b>	Realize the concept of projection and attain visualization projection of points, Lines and Planes. The student will also be able to draw the views related to projection of Points, Lines and Planes.
<b>CO6</b>	Analyze the concept of orthographic projections and student will be able to draw orthographic views of an object from its pictorial drawing.

### Blueprint for Marks in SEE

Unit No	Name of the Unit	Periods	Questions to be set for SEE		
			R	U	A
			PART-A (2M Questions)		PART-B (6M Questions)
1, 2 & 3	Importance of Engineering Drawing and Instruments, Free hand lettering and Numbering and Dimensioning Practice	09	Q1	Q9(a)	
4a.	Geometric constructions up to construction of polygons	06	Q2	Q9(b)	
4b.	Geometric constructions contd., Conical curves and Special curves	06	Q3	Q10(a)	
5	Projection of points, Lines, and Planes	09	Q4	Q10(b)	
6	Orthographic projections	15	Q5, Q6, Q7, Q8	Q11(a), Q11(b), Q12(a), Q12(b)	
Total Periods / Total Questions		45	8	4	
<p>[ R: Remembering; U: Understanding – 2 Marks; A: Application – 6 Marks]</p> <p><u>Note: Question Paper consists PART – A and PART-B</u>            PART – A consists of 8 questions) and student has to answer ALL questions, each question carries 2 marks. (8x2 = 16)            PART – B consists of 4 questions and student has to attempt ALL questions, each question carries 6 marks (4x6=24)</p>					

### CIE Question Paper Pattern and Syllabus

Unit No	Name of the Unit	Periods	Questions to be set for CIE		
			R	U	A
			PART-A (2M Questions)		PART-B (6M Questions)
<b>Mid Sem – I Exam</b>					
1, 2 & 3	Importance of Engineering Drawing and Instruments, Free hand lettering and Numbering and Dimensioning Practice	09	Q1, Q2	Q5(a), Q5(b)	
4a.	Geometric constructions up to construction of polygons	06	Q3, Q4	Q6(a), Q6(b)	
Total			4	2	
<b>Mid Sem – II Exam</b>					
4b.	Geometric constructions contd., Conical curves and Special curves	06	Q1, Q2	Q5(a), Q5(b)	
5	Projection of points, Lines, and Planes	09	Q3, Q4	Q6(a), Q6(b)	
Total			4	2	
<p>[ R: Remembering; U: Understanding – 2 Marks; A: Application – 6 Marks]</p> <p><u>Note: Question Paper consists PART – A and PART-B</u>            PART – A consists of 4 questions and student has to answer ALL questions, each question carries 2 marks. (4x2 = 8)            PART – B consists of 2 questions and student has to attempt ALL questions, each question carries 6 marks (2x6=12)</p>					

## Course Contents

### NOTE:

1. B.I.S Specification should invariably be followed in all the topics.
2. A-3 Size Drawing Sheets are to be used for all Drawing Practice Exercises.

### **1.0 The importance of Engineering Drawing and Engineering Instruments**

Explanation of the scope and objectives of the subject of Engineering Drawing Its importance as a graphic communication -Need for preparing drawing as per standards – SP-46 –1988 – Mention B.I.S - Role of drawing in -engineering education – Link between Engineering drawing and other subjects of study.

#### **Engineering drawing Instruments**

Classifications: Basic Tools, tools for drawing straight lines, tools for curved lines, tools for measuring distances and special tools like mini drafter & drafting machine – Mentioning of names under each classification and their brief description -Scales: Recommended scales reduced & enlarged -Lines: Types of lines, selection of line thickness - Selection of Pencils -Sheet Sizes: A0, A1, A2, A3, A4, A5, Layout of drawing sheets in respect of A0, A1, A3 sizes, Sizes of the Title block and its contents, Care and maintenance of Drawing Sheet, Drawing plate:

Lay out of sheet – as per SP-46-1988 to a suitable scale.

### **2.0 Free hand lettering & numbering**

Importance of lettering – Types of lettering -Guide Lines for Lettering  
Practicing of letters & numbers of given sizes (7mm, 10mm and 14mm)  
Advantages of single stroke or simple style of lettering - Use of lettering stencils

### **3.0 Dimensioning practice**

Purpose of engineering Drawing, Need of B.I.S code in dimensioning -Shape description of an Engineering object -Definition of Dimensioning size description - Location of features, surface finish, fully dimensioned Drawing -Notations or tools of dimensioning, dimension line extension line, leader line, arrows, symbols, number and notes, rules to be observed in the use of above tools -Placing dimensions: Aligned system and unidirectional system (SP-46-1988)-Arrangement of dimensions Chain, parallel, combined progressive, and dimensioning by co-ordinate methods-The rules for dimensioning standard, features: Circles (holes) arcs, angles, tapers, chamfers, and dimension of narrow spaces.

### **4.0 Geometric Construction**

Division of a line: to divide a straight line into given number of equal parts internally examples in engineering application. Construction of tangent lines: to draw tangent lines touching circles internally and externally.

Construction of tangent arcs

- a) To draw tangent arc of given radius to touch two lines inclined at given angle (acute, right and obtuse angles).
- b) Tangent arc of given radius touching a circle or an arc and a given line.
- c) Tangent arcs of radius R, touching two given circles internally and externally.

Construction of polygon: construction of any regular polygon of given side length using general method.

Conical Curves: Explanation of Ellipse, Parabola, Hyperbola, as sections of a double cone and a loci of a moving point, Eccentricity of above curves – Their Engg. application viz. Projectiles, reflectors, P-V Diagram of a hyperbolic process.

**Conical Curves:** Construction of any conic section of given eccentricity by general method.

Construction of ellipse by concentric circles method.

Construction of parabola by rectangle method.

Construction of rectangular hyperbola.

**Special Curves:** Involute, Cycloid and Helix, explanations as locus of a moving point, their engineering application, viz, Gear tooth profile, screw threads, springs etc. - their construction

## 5.0 Projection of points, lines and planes

Projecting a point on two planes of projection -Projecting a point on three planes of projection -Projection of straight line.

- a) Parallel to both the planes.
- b) Perpendicular to one of the planes.
- c) Inclined to one plane and parallel to other planes.

Projection of regular planes.

- a) Plane perpendicular to HP and parallel to VP and vice versa.
- b) Plane perpendicular to HP and inclined to VP and vice versa.

## 6.0 Orthographic Projections

Meaning of orthographic projection -Using a viewing box and a model – Number of views obtained on the six faces of the box - Legible sketches of 3 views for describing object -Concept of front view, top view, and side view for sketching these views of engineering objects - Explanation of first angle projection. – Positioning of three views in First angle projection - Projection of points as a means of locating the corners of the surfaces of an object – Use of miter line in drawing a third view when other two views are given -Method of representing hidden lines -Selection of minimum number of views to describe full object.

## Reference Books

1. Engineering Drawing by N.D. Bhatt (Charotar Publishing House Pvt. Ltd.)
2. Engineering Drawing by Kapil dev – (Asian Publisher)

3. Engineering Drawing by Basant Agarwal & C. M. Agarwal - ( McGraw-hill)
4. A Textbook on Engineering Drawing by P. Kannaiah, K. L. Narayana, K. Venkata Reddy

### Online Resources

1. [1.https://nptel.ac.in/courses](https://nptel.ac.in/courses)
2. [2. www.slideshare.net/shameem.mist/engineering-drawing](http://www.slideshare.net/shameem.mist/engineering-drawing)
3. [3.https://www.powershow.com/viewfl/76303a-](https://www.powershow.com/viewfl/76303a-)
4. OWI5M/Engineering\_Drawing\_powerpoint\_ppt\_presentation
5. [4.https://www.powershow.com/view0/91a2bf-](https://www.powershow.com/view0/91a2bf-)
6. N2Q2N/Basic\_engineering\_drawing\_solved\_question\_powerpoint\_ppt\_presentation

### Suggested Learning Outcomes

Upon completion of the subject, the student shall be able to

#### 1.0 Understand the basic concepts of engineering drawing

- 1.1 State the importance of drawing as an engineering communication medium
- 1.2 State the necessity of B.I.S. Code of practice for Engineering Drawing.
- 1.3 Explain the linkages between Engineering drawing and other subjects of study in diploma course.

#### Use of Engineering Drawing Instruments

- 1.4 select the correct instruments and draw lines of different orientation.
- 1.5 Select the correct instruments and draw small and large Circles.
- 1.6 Select the correct instruments for measuring distances on the drawing.
- 1.7 Use correct grade of pencil for different types of lines, thickness and given function.
- 1.8 Select and use appropriate scales for a given application.
- 1.9 Identify different drawing sheet sizes as per I.S. and Standard Lay- outs.
- 1.10 Prepare Title block as per B.I.S. Specifications.

#### 2.0 Write Free Hand Lettering and Numbers

- 2.1 Write titles using sloping lettering and numerals of 7mm, 10mm and 14mm height
- 2.2 Write titles using vertical lettering and numerals of 7mm, 10mm and 14mm height
- 2.3 Select suitable sizes of lettering for different layouts and applications
- 2.4 Practice the use of lettering stencils.

#### 3.0 Understand Dimensioning Practice

- 3.1 Define “Dimensioning.
- 3.2 State the need of dimensioning of drawing according to accepted standard.
- 3.3 Identify notations of Dimensioning used in dimensioned drawing.

- 3.4 Identify the system of placement of dimensions in the given dimensioned drawing.
- 3.5 Dimension a given drawing using standard notations and desired system of dimensioning.
- 3.6 Dimensioning standard features applying necessary rules.
- 3.7 Arrange dimensions in a desired method given in a drawing.
- 3.8 Identify the departures if any made in the given dimensioned drawing with reference to SP-46-1988, and dimension the same correctly.

#### **4.0 Apply Principles of Geometric Constructions**

- 4.1 Divide a given line into desired number of equal parts internally.
- 4.2 Draw tangent lines and arcs.
- 4.3 Use General method to construct any polygon.
- 4.4 Explain the importance of conics.
- 4.5 Construct conics (ellipse, parabola and hyperbola) by general method.
- 4.6 Construct ellipse by concentric circles method.
- 4.7 Construct parabola by rectangle method.
- 4.8 Construct rectangular hyperbola from the given data.
- 4.9 Construct involute from the given data.
- 4.10 Construct cycloid and helix from the given data.
- 4.11 State the applications of the above constructions in engineering practice.

#### **5.0 Apply Principles of Projection of points, lines and planes (06 Hours)**

- 5.1 Visualize the objects
- 5.2 Explain the I-angle and III-angle projections
- 5.3 Practice the I-angle projections
- 5.4 Draw the projection of a point with respect to reference planes (HP&VP)
- 5.5 Draw the projections of straight lines with respect to two reference Planes (up to lines parallel to one plane and inclined to other plane)
- 5.6 Draw the projections of planes (up to planes perpendicular to one plane and inclined to other plane)

#### **6.0 Apply principles of orthographic projection**

- 6.1 Explain the principles of orthographic projection with simple sketches.
- 6.2 Draw the orthographic view of an object from its pictorial drawing.
- 6.3 Draw the minimum number of views needed to represent complete engineering component.

## Course Outcomes (CO)

Upon successful completion of the course, the students will be able to

Course Outcome		Cognizant Level	Linked Program Objectives (PO)
CO1	Acquiring the knowledge about the importance of Engineering drawing and Drawing instruments usage.	R	1, 4, 7
CO2	Practicing free hand Lettering & Numbering in different styles.	R/U	1, 3, 4, 7
CO3	Acquiring the knowledge about different methods of dimensioning systems.	R/U	1,3, 4, 7
CO4	Appreciate the usage of engineering curves for tracing the paths and surface profile of the machine components such as gear profile from involute and cycloid., cooling towers from hyperbola, automobile headlights from ellipse and dish antenna from parabola etc.	R/U/A	1, 2, 3, 4, 7
CO5	Realize the concept of projection and attain visualization projection of points, Lines and Planes. The student will also be able to draw the views related to projection of Points, Lines and Planes.	R/U/A	1, 2, 3, 4,6, 7
CO6	Realize the concept of orthographic projections and student will be able to draw orthographic views of an object from its pictorial drawing.	R/U/A	1, 2, 3, 4, 7

## CO-PO MATRIX:

CO	PO1	PO2	PO3	PO4	PO5	PO6	PO7
CO1	3	-	-	3	-	-	3
CO2	3	-	1	2	-	-	3
CO3	3	-	1	2	-	-	2
CO4	3	1	2	2	-	-	2
CO5	3	3	2	2	-	1	1
CO6	3	1	3	3	-	-	2

**BOARD DIPLOMA EXAMINATION, (C-21)**  
**DME – I SEMESTER**  
**ME-106, MID SEMESTER - I EXAMINATION**  
**BASIC ENGINEERING DRAWING**

**Time: 1 Hour]**

**[Total Marks: 20**

**PART-A**

04x02=08

**Instructions :**

1. Answer **ALL** questions.
2. Each question carries **TWO** marks.

1. Write freehand the following, using single stroke vertical capital letters of height 12 mm.  
'NECESSITY IS THE MOTHER OF INVENTION'
2. Redraw the following figure in Uni-Directional system of dimensioning.

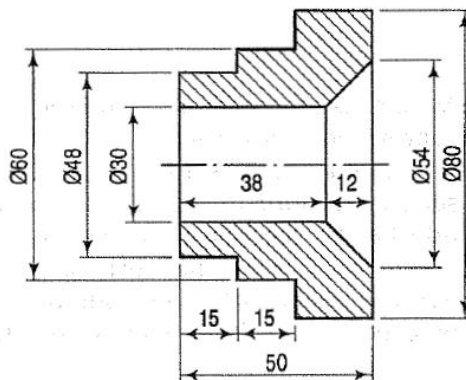

3. To divide a straight line of 70mm into 6 equal parts.
4. Bisect a given line AB of length 75mm.

**PART-B**

02x06=12

**Instructions :**

1. Answer **ALL** questions.
2. Each question carries **SIX** marks.

5. (a) Redraw the following figure with chain dimensioning.

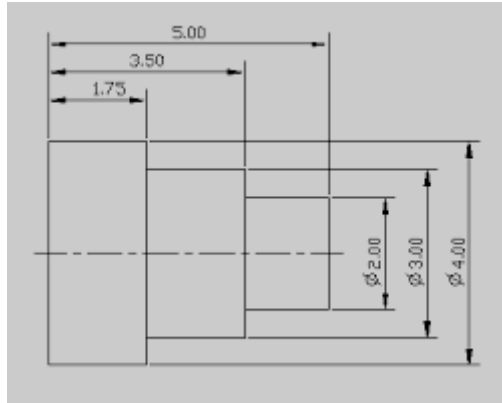

(Or)

5. (b) Redraw the following figure in aligned system of dimensioning.

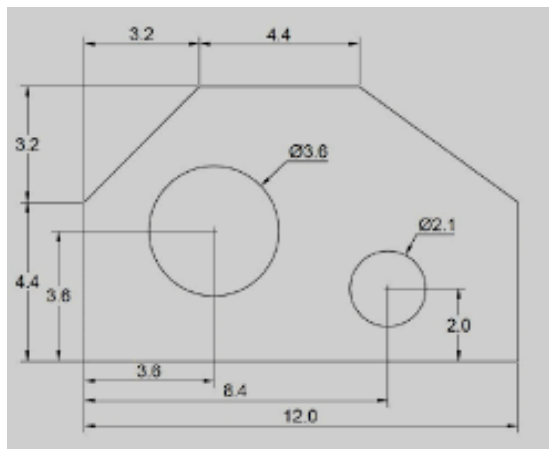

6. (a) Construct a regular pentagon of base side 30 mm in general method.

(Or)

6. (b) Draw an arc of radius 30 mm touching the given straight line AB of length 70 mm and passing through a point 'P' which is 55 mm above the line AB.

**BOARD DIPLOMA EXAMINATION, (C-21)**  
**DME – I SEMESTER**  
**ME-106 MID SEMESTER - II EXAMINATION**  
**BASIC ENGINEERING DRAWING**

**Time: 1 Hour]**

**[Total Marks: 20**

---

**PART-A**

04x02=08

- Instructions :**
1. Answer **ALL** questions.
  2. Each question carries **TWO** marks.
1. Draw an arc of radius 30 mm touching the two given straight lines AB and AC making an angle  $45^{\circ}$  with each other.
  2. Draw an internal common tangent for the two given circles of equal radius of 30 mm if the centre distance is 75 mm.
  3. Draw the projections of a point A lying on both the planes.
  4. A line AB of length 70 mm is parallel to V.P. and inclined an angle of  $30^{\circ}$  to H.P. Draw its projections when its end A is on the H.P. and 20 mm in front of V.P.

**PART-B**

02x06=12

- Instructions :**
1. Answer **ALL** questions.
  2. Each question carries **SIX** marks.
5. (a) Construct an ellipse if the distance between focus and the directrix is 50 mm by eccentricity method. Also draw the normal and tangent at any point on the curve.  

(Or)
  5. (b) Construct the locus of a point 'P' which is on the circumference of circle of radius 25 mm when it is rolling on a straight line for one complete revolution without slipping. Also name the curve.
  6. (a) Draw the projections of a line AB of length 75 mm parallel to HP and inclined at an angle of  $30^{\circ}$  to VP. The end A is 30 mm from both the reference planes.  

(Or)
  6. (b) A square of base side 40 mm is perpendicular to both the reference planes. Draw its projections.

**MODEL PAPER SEE**  
**ME-106 BOARD DIPLOMA EXAMINATION, (C-21)**  
**DME – I SEMESTER EXAMINATION**  
**BASIC ENGINEERING DRAWING**

**Time: 2hours]**

**[Total Marks: 40**

**Important Note:** Wherever any question has choice, marks will be allotted only to first attempted question. No marks will be allotted for extra questions answered.

**PART-A**

08x02=16

**Instructions :**

1. Answer **ALL** questions.
2. Each question carries **TWO** marks.
3. All the dimensions are in mm.
1. Write the following, using single stroke vertical capital letters of size 10 mm:  
'DEVELOP AN ATTITUDE OF GRATITUDE'
2. Bisect the given angle of  $55^{\circ}$ .
3. Inscribe a pentagon in a given circle of radius 35 mm.
4. Draw the projections of a point 'P' lying on HP and 30 mm behind VP.
5. Draw the top view of a circular plane of diameter 50mm when its plane is perpendicular to HP.
6. Draw the projections of a cube of base side 30 mm when it is resting on one of its base on HP with one of its vertical face is parallel to VP.
7. Draw the front view of the block shown in figure

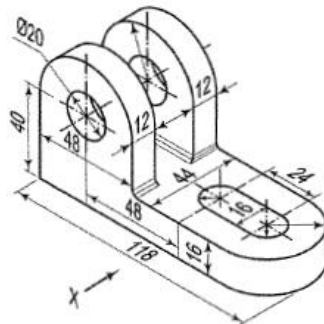

8. Draw the front view of the block shown in figure



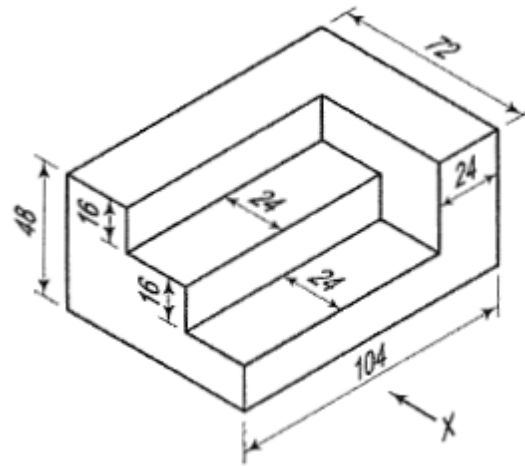

(Or)

11. (b) Draw the top view from the component as shown in figure.

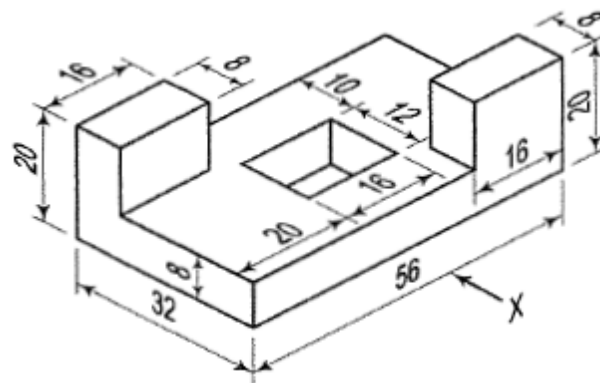

12. (a) Draw the frontview of component shown in figure

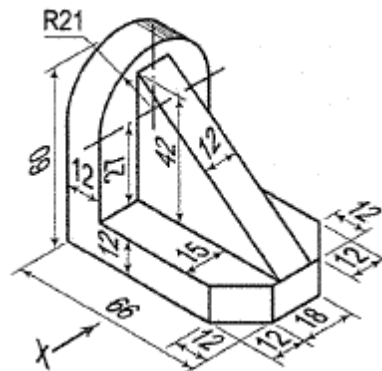

(Or)

12 (b) Draw the top view and front view of the component as shown in figure

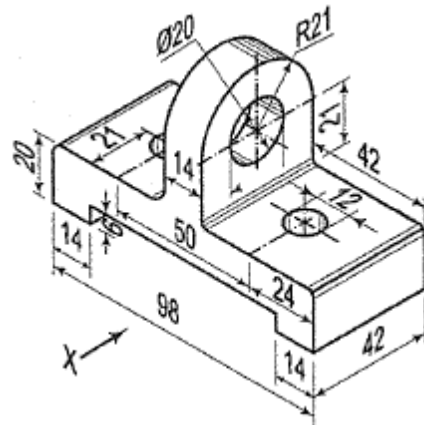

## ME-107 - BASIC AUTOCAD LAB

Course Title :	Basic AutoCAD Lab	Course Code	ME-107
Semester	I	Course Group	Core
Teaching Scheme in periods (L:T:P)	1:0:2	Credits	1.5
Methodology	Lecture + Practice	Total Contact periods	45 Periods
CIE	60 Marks	SEE	40 Marks

### Pre requisites:

This course requires the Basic Computer Skills and Practice concepts of engineering drawing

### Course Outcomes

<b>CO1</b>	Importance and advantages of CAD. Set drawing area and draw geometric shapes and modify as per requirement
<b>CO2</b>	Creating new objects by using draw commands
<b>CO3</b>	Modifying the existing drawing using modify commands
<b>CO4</b>	Add dimensions and text with required font and size.
<b>CO5</b>	Generate isometric model and draw circle on three iso planes
<b>CO6</b>	Create 2D drawings with front, side view with all above features

### Course Content

#### UNIT -1

**Duration: 15 periods (T:5 + P:10)**

##### 1.1 The Computer Aided Drafting and its software

Definition of Computer Aided Drafting, the Advantages and importance of CAD software LIKE Auto CAD, Intelli Cad, ProG CAD etc., the features of Graphic Work station, CAD Environment: Screen, Various tool bars and menus.

##### 1.2 Selection of commands

Commands using toolbars, menus, command bar. Repeating a command, Nesting a command and modifying a command. Use of prompt history window and scripts, mouse shortcuts. Creating the drawing. Opening existing and, saving of drawing, setting up a drawing. Setting and changing the grid and snapping alignment, and the Entity snaps.

##### 1.3 Use of viewing tools of CAD & Use of coordinate systems of the drawing

Use of mouse, Scroll bar to move around within drawing, changing of magnification of drawing. Displaying of multiple views, the use of controlling visual elements like Line weight and line types.

Two dimensional coordinates such as Absolute, Cartesian, Relative Cartesian and Polar coordinates and direct method of drawing line.

#### **1.4 Creating simple and complex entities**

Drawing of lines, circles, arcs, ellipses, elliptical arcs, rays and infinite lines, rectangles, polygons,

#### **1.5 Use the simple Modifying tools to modify the properties of entities**

Entity selection and de selection methods, the Deletion of entities. Copying of entities within a drawing, between drawings, parallel copies,

### **UNIT -2**

**Duration: 15 periods (T:5 + 10P)**

#### **2.1 Use the Modifying tools to modify the properties of entities**

Mirroring entities and arraying entities. The Rearranging of entities by Moving, Rotating and Reordering. The Resizing of entities by Stretching, Scaling, Extending, Trimming, and editing the length. The Braking and joining of entities. Chamfering and Filleting of entities

#### **2.2 Creating complex entities**

Drawing of shapes like rectangle, Polygon, polylines, Splines, donuts, and adding of hatch pattern

#### **2.3 Use the drawing information retrieving tools Measure, Divide, Calculate and Display**

Creating and editing of point entities. Dividing the entities in to segments. Calculation of areas of defined by points, closed entities, and combined entities, calculate the distance and angle between the entities. Displaying the information about the entities and drawing status.

#### **2.4 Use the Text tool to create and formatting the various types of text Fonts and its styles**

The creating, naming and modifying the text fonts, the Creation of line text, paragraph text, setting of line text style and its alignment. The Setting of Paragraph text style and its alignment, and modifying the text. Rectangular and polar array

#### **2.5 Use Dimensioning concepts to create, Edit ,Control dimension styles & variables and Adding geometric tolerances**

The creating of linear, Angular, Diametral, Radial, Ordinate dimensions. The creating leaders and annotations, making dimensions oblique, Editing the dimension text, controlling of dimension arrows and format. The Controlling of line settings and dimension text, the Controlling of dimension units, and dimension tolerance.

## 2.6 Isometric Views

Setting of isometric grid – change of iso planes, drawing straight line and circle  
Create Isometric views of simple objects

## .UNIT -3

**Duration: 15 periods (T:3 + P:10)**

**Practise of 2D Drawings consisting** of different line types, line weights, hatch, dimensioning and Text

Using appropriate commands creation of 2D drawings of standard components

### Specific Learning Outcomes

## UNIT-1

**Duration: 15 periods (T:3 + P:10)**

**Upon completion of the course the student shall be able to Understand about the**

### 1. Computer Aided Drafting and its software

- 1.1 Define Computer Aided Drafting
- 1.2 List the Advantages of CAD and also various CAD software's
- 1.3 Explain the importance of CAD software
- 1.4 Explain the features of Graphic Work station
- 1.5 Explain CAD Screen, Various tool bars and menus
- 1.6 Explain the benefits of Templates
- 1.7 Identify various CAD software's and their features

### Use appropriate selection commands

- 1.8 Practice commands using toolbars, menus, command bar
- 1.9 Practice repeating a command, Nesting a command and modifying a command
- 1.10 Use prompt history window and scripts
- 1.11 Know the use of mouse for zooming and pan
- 1.12 Practice the Creating the drawing, saving the drawing with .drawing extension and Opening Existing drawing
- 1.13 Practice the setting up a drawing with drawing limits and drawing units.
- 1.14 Practice the setting and changing the ortho, grid and snapping alignment
- 1.15 Practice the Entity snaps

### Use viewing tools of CAD & Use coordinate systems of the drawing

- 1.16 Practice the use of Scroll bar, pan command and rotating view to move around within drawing
- 1.17 Practice the changing of magnification of drawing

- 1.18 Practice how the coordinate system work and it is displayed
- 1.19 Practice the Two dimensional coordinates such as Absolute Cartesian, Relative Cartesian, Polar coordinates and direct method to draw a line.
- 1.20 Explain importance and use of Osnap/ Esnap points.
- 1.21 Practice to draw with other drawing commands like circle, polygon and other.

### **Create the simple and complex entities**

- 1.22 Draw the lines, circles, arcs, ellipses, elliptical arcs, rays and infinite lines.

## **UNIT -2**

**Duration: 15 periods (T:3 + P:10)**

### **2. Use the modifying tools to modify the properties of entities**

- 2.1 Practice the various methods of entity selection like window, cross window, fence, last and previous methods and deselect ion method
- 2.2 Draw shapes like Rectangles, Polygons, Polylines, Splines, donuts
- 2.3 Practice the adding of hatch with required pattern and adjusting line angle and line space.
- 2.4 Practice the Deletion, breaking and trimming of entities
- 2.5 Practice the Copying of entities within a drawing, between drawings
- 2.6 Practice the Chamfering and Filleting of entities
- 2.7 Practice the making of parallel copies, Mirroring entities and Arraying entities
- 2.8 Practice the Rearranging of entities by Moving, Rotating and Reordering
- 2.9 Practice the Resizing of entities by Stretching, Scaling, and Extending.
- 2.10 Practice the Editing of polylines: Opening, Closing, Curving, Decurving, Joining, Changing width and editing vertices
- 2.11 Practice the Exploding of entities

### **Use the drawing information retrieving tools Measure, Divide, Calculate, Display, and Track**

- 2.12 Divide the entities in to required number of segments
- 2.13 Calculate the areas defined by points, of closed entities, and combined entities
- 2.14 Calculate the distance between the entities
- 2.15 Calculate the angle between the entities
- 2.16 Display the information about the entities and drawing status
- 2.17 Track time spent working on a drawing

### **Use the Text tool to create and formatting the various types of text fonts and its styles**

- 2.18 Practice the creating, naming and modifying the text fonts
- 2.19 Practice the Creation of line text, paragraph text
- 2.20 Practice the Setting of line text style and its alignment
- 2.21 Practice the Setting of Paragraph text style and its alignment

- 2.22 Practice the Changing of line text and Paragraph text
- 2.23 Practice the use of alternate text editor

**Use Dimensioning concepts to create dimensions, Edit dimensions, Control dimension styles & variables and Adding geometric tolerances**

- 2.24 Practice the creating of linear, Angular, Diametral, Radial, Ordinate dimensions
- 2.25 Practice the creating leaders and annotations
- 2.26 Practice the making dimensions oblique,
- 2.27 Edit the dimension text
- 2.28 Practice the Controlling of dimension properties like arrow types, size, dim line adjustment, dim offset, text size: primary and secondary units and format
- 2.29 Practice the Controlling of dimension units, and dimension tolerance

**UNIT-3**

**Duration: 15 periods (T:3 + P:10)**

**3. Create 2D Drawings**

- 3.1 Create 2D drawings of standard mechanical components with dimensions and text

**Recommended Books**

1. AutoCAD by George Omura
2. 4MCAD User Guide- IntelliCAD Technology Consortium

**Key competence to be achieved by students / Suggested Learning Outcomes**

S.No	Experiment Title	Key components
1	Introduction to CAD	<ul style="list-style-type: none"> <li>• Open / close AutoCAD program</li> <li>• Understands AutoCAD Graphic User Interface(GUI) and various toolbars</li> </ul>
2	Selecting commands & Working withdrawing	<ul style="list-style-type: none"> <li>• Use prompt history window and scripts</li> <li>• Practice the setting up a drawing</li> <li>• Practice the Entity</li> </ul>
3	a) Viewing drawing	<ul style="list-style-type: none"> <li>• Use Scroll bar, pan command, and rotating view to move around within drawing</li> <li>• Control visual elements like Fill, Text, Blips and</li> <li>• Line weight</li> </ul>
	b) Working with coordinates	<ul style="list-style-type: none"> <li>• Use Two dimensional coordinates and Three dimensional coordinates</li> <li>• Use right-hand rule</li> <li>• Use filters in two and three dimensions</li> <li>• Define user coordinate system</li> </ul>
4	Creating simple and complex	<ul style="list-style-type: none"> <li>• Draw the simple shapes like lines, circles, arcs</li> </ul>

	entities	<ul style="list-style-type: none"> <li>and complex shapes like polygons, planes etc.,</li> <li>Practice adding of hatch pattern</li> </ul>
5	Getting Drawing information	<ul style="list-style-type: none"> <li>Measure the intervals and distance between Entities.</li> <li>Divide the entities in to segments</li> <li>Calculate the areas defined by points, of closed entities, and Combined entities</li> </ul>
6	Use the Text tool to create various types of text fonts and its styles	<ul style="list-style-type: none"> <li>Calculate the areas defined by points, of closed entities, and Combined entities</li> <li>Use filters in two and three dimensions</li> <li>Draw the simple shapes like lines, circles, arcs and complex shapes like polygons, planes etc.,</li> <li>Practice the adding of hatch pattern</li> </ul>
7	Dimensioning drawing	<ul style="list-style-type: none"> <li>Practice the Controlling of dimension properties like arrow types, size, dim line adjustment, dim offset, text size , primary and secondary units and format</li> <li>Practice the Controlling of dimension units, and dimension tolerance</li> </ul>
8	Isometric Views	<ul style="list-style-type: none"> <li>Use Iso snap command to create Isometric views</li> </ul>
9	2D Drawings	<ul style="list-style-type: none"> <li>Use proper 2D commands to create 2D drawings</li> </ul>

Course Outcomes		CL	Linked PO	Teaching Hours
CO1	Importance and advantages of CAD. Set drawing area and draw geometric shapes and modify as per requirement	U/A	1,2,3,4,7	3
CO2	Creating new objects by using draw commands	U/A	1,2,3,4	12
CO3	Modifying the existing drawing using modify commands	U/A	1,2,3,7	6
CO4	Add dimensions and text with required font and size.	A	1,2,3,4	6
CO5	Generate isometric model and draw circle on three iso planes	U/A	1,2,3,4,7	3
CO6	Create 2D drawings with front, side view with all above features	A	1,2,3,4,7	15

**MID SEM-I EXAM**

<b>S.No</b>	<b>Unit Name</b>	<b>R</b>	<b>A</b>	<b>Remarks</b>
1	Unit-I	1, 2,3,4	5,6	
<b>Total Questions</b>		<b>4</b>	<b>2</b>	

**MID SEM –II EXAM**

<b>S.No</b>	<b>Unit Name</b>	<b>R</b>	<b>A</b>	<b>Remarks</b>
1	Unit-II	1, 2,3,4	5,6	
<b>Total Questions</b>		<b>4</b>	<b>2</b>	

### SEMESTER END EXAM

S N	Unit name	Questions to be set for SEE		Remarks
		R, U	A	
1	Unit-1	1,2		
2	Unit-2	3,4		
3	Unit-3		5, 6	

### CO-PO MAPPING MATRIX

CO	PO1	PO2	PO3	PO4	PO5	PO6	PO7
CO1	3	1	1	3	-	-	3
CO2	3	1	1	2	-	-	3
CO3	3	1	1	2	-	-	2
CO4	3	-	-	2	-	-	2
CO5	3	1	1	2	1	-	1
CO6	3	2	3	3	-	1	2

**ME-107 - Basic AutoCAD Lab**  
**MODEL PAPER FOR MID -1 (CIE)**

**TIME: 1hr**

**Marks: 20M**

.....

**PART-A**

NOTE: Answer all questions  
8marks

4 X 2 =

1. Draw a square of 50x50mm by using any CAD software.
2. Draw an equilateral triangle of 50mm side by using any CAD software.
3. Draw an ellipse with major axis 80mm and minor axis 30mm by using any CAD software.
4. Draw a line of 50mm and draw five parallel lines at 10mm distance by using offset command

**PART-B**

NOTE: Answer any one questions  
12marks

1 X 12 =

5. Draw the following using any CAD software without dimensioning.

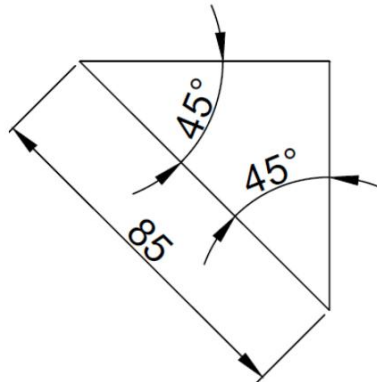

6. Draw the following using any CAD software without dimensioning.

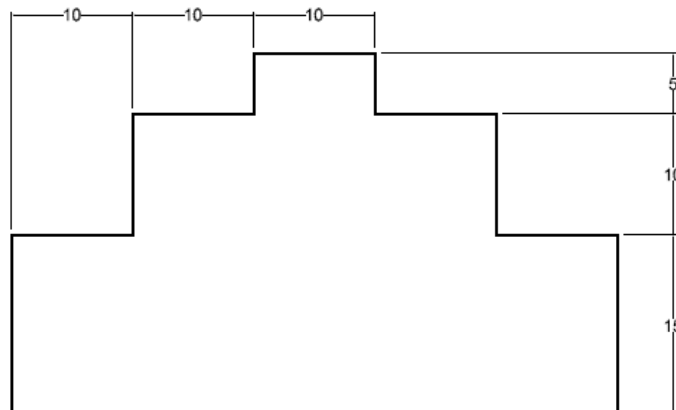

**ME-107 - Basic AutoCAD Lab**  
**MODEL PAPER FOR MID -2 (CIE)**

**TIME: 1hr**

**Marks: 20M**

**PART-A**

NOTE: Answer all questions  
8marks

4 X 2 =

1. Write text "CAD Lab" with Calibri font style and font size 10 by using any CAD software.
2. Draw a line of 10mm and divide it into four equal parts by modifying the point style to x shape.
3. Add continuous dimensions to divided line drawn in Q no. 2.
4. Draw a pentagon of side 60mm and calculate its area by using any CAD software.

**PART-B**

NOTE: Answer any one questions  
12marks

1 X 2 =

5. Draw the following using any CAD software and add dimensioning.

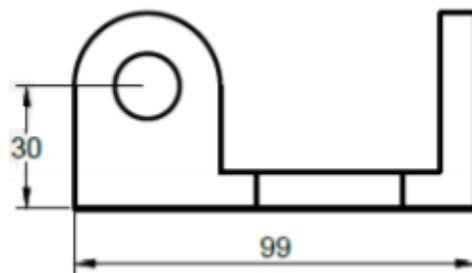

6. Draw the following using any CAD software and add dimensioning.

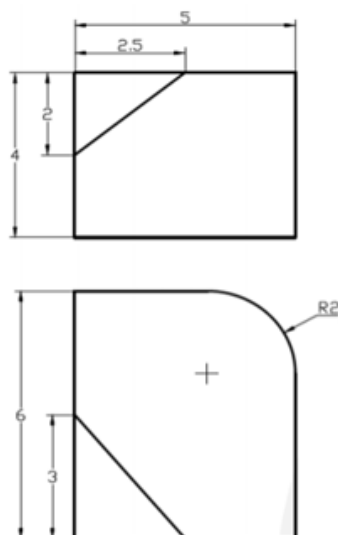

**ME-107 - Basic AutoCAD Lab**  
**MODEL PAPER FOR SEE**

**TIME: 2hr**

**Marks: 40M**

**PART-A**

NOTE: Answer all questions  
16marks

4 X 4 =

1. Draw the following fig by using any CAD software, change the line type and add dimensions. Also list the commands used in sequence.

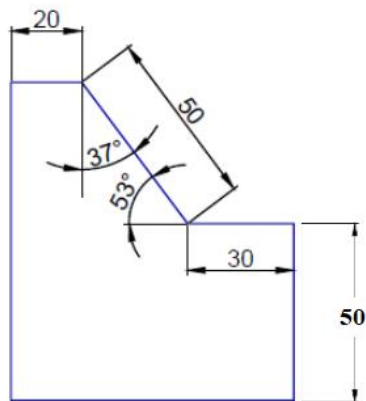

2. Draw the following arrow mark by using any CAD software, and add complete dimensions. Also list the commands used in sequence.

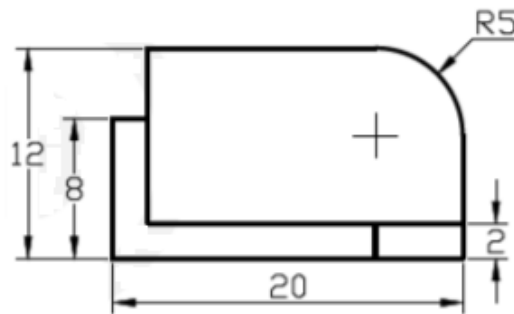

3. Redraw the following figure and add dimensions as shown in figure.

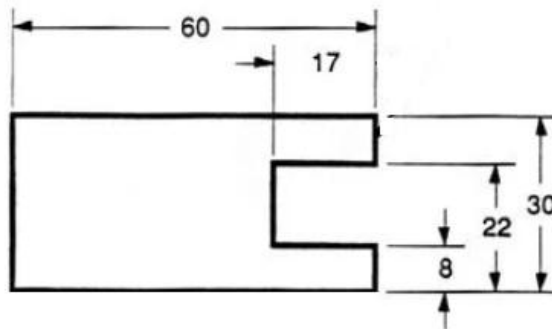

4. Draw isometric view of a cube of 100mm side by using any CAD software.

**PART-B**

NOTE: Answer any one questions

1 X 24 = 24marks

5. (a) Draw the following using any CAD software and add dimensioning. 15+5+4 marks  
(b) List the commands in sequence and also write the procedure  
(c) Add title box containing Student PIN, name and college name

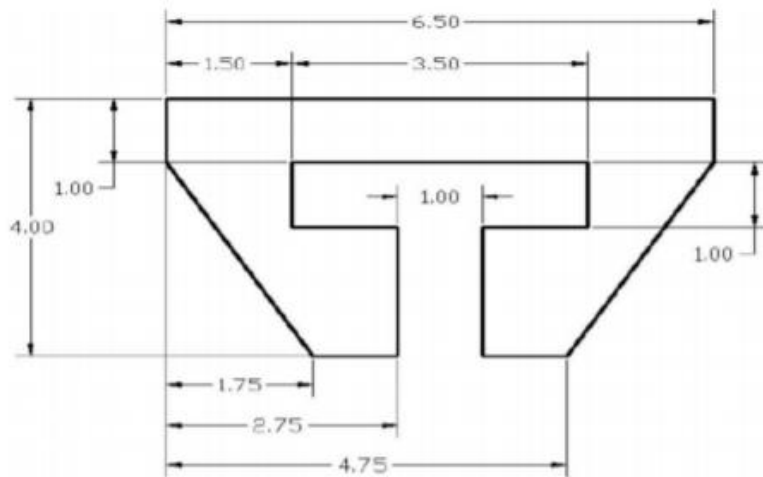

6. (a) Draw the following using any CAD software and add dimensioning. 15+5+4 marks  
(b) List the commands in sequence and also write the procedure  
(c) Add title box containing Student PIN, name and college name

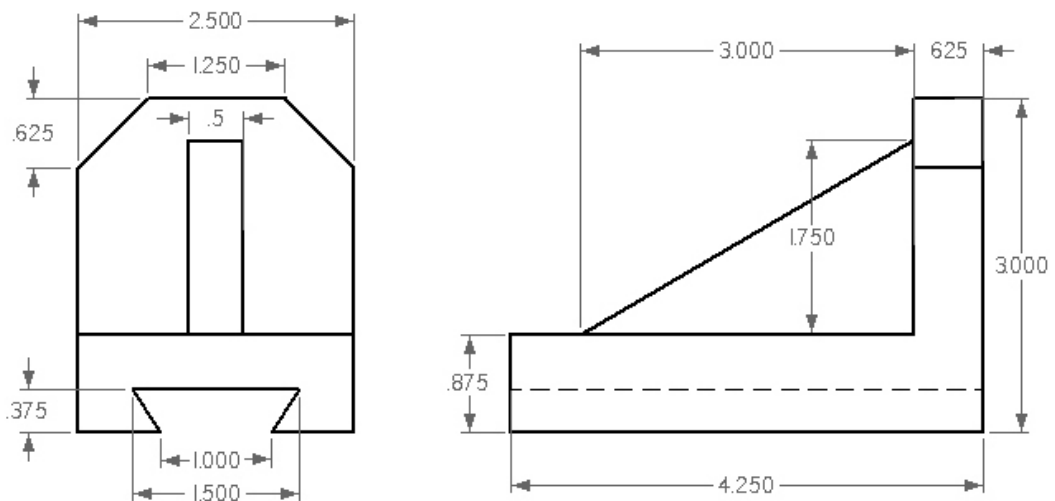

## EC-108 - BASIC ELECTRICAL & ELECTRONICS ENGINEERING LAB

Course Title	Basic Electrical & Electronics Engineering Lab	Course Code	EC-108
Semester	I	Course Group	Core
Teaching Scheme in Periods(L:T:P)	1:0:2	Credits	1.5
Methodology	Lecture + Practical	Total Contact Periods	45
CIE	60 Marks	SEE	40 Marks

**Pre requisites:** This course requires the basic skills of handling basic tools

### Course outcomes:

Course Outcome		CL	Linked PO	Teaching Hours
CO1	Identify the significance of Safety Hazards and preventive methods, and apply them for safe and efficient Laboratory practice.	R/U/A	1,2,3,4,5,6,7,8	15
CO2	Identify of different wires, cables and apply them for simple House wiring applications	R/U/A	1,2,3,4	12
CO3	Use basic Electronic measuring Instruments	R/U/A	1,2,3	9
CO4	Design simple circuit using Electronic components	A	1,2,3,10	9
			TOTAL	45

### Course Contents

#### I. Electrical Wiring

1. A) Read Safety precautions and Identify various Symbols related to a ) safety b) Electrical Engineering c) Electronic components  
B) Identify different a) wires and cables b) Electrical Accessories c) electronic components
2. Identify the terminals of Electrical accessories like a) Two pin socket b) 3 Pin socket c) Power socket d) power plug and make connections.
3. Make simple switch connections using low voltage transformer and 12V lamp
4. Make either of two lamps glow by two-way switch

#### II. Electronic Instruments & Electronic components

5. Identify and practice the operation the following equipment a) DC Regulated power supply b) Digital Multimeter c) Decade Resistance box d) decade capacitance box

6. Identify Different Electronic Components a) Resistors b) Capacitors and C) Inductors & Transformers, read their value and verify the value of Resistors with Digital multimeter
7. A) Verify the laws of Resistance using a nichrome wire and Multimeter  
B) Verify the effect of temperature
8. Measure the current flowing through a two Resistors connected in series and voltage drops across each resistors for different combinations of Resistors (Use Decade Resistance boxes)
9. A.) Verify voltage and current relationship in series and parallel resistive circuits.  
B) Connect Resistors in series and parallel combination to get the required value and Verify with DMM

### **III. Capacitors & Transformers**

10. A) Connect Electrolytic Capacitors in Series and Parallel and observe the voltage division  
B) Connect a) DC source b) AF generator to a capacitor alternately and verify that Capacitor blocks DC and allows AC.
11. Measure the Resistance of Primary and Secondary windings of Transformer with Digital Multimeter
12. Identify Normal and centre tapped Transformers and measure the voltage across secondary winding terminals
13. Experimentally Verify that same Transformer can be used as Step-down transformer and as Step-up Transformer
14. Experimentally Verify that the transformer does not change the frequency of output voltage/Current.

### **IV. Soldering Practice**

15. Practice soldering of a) Resistors b) Capacitors c) wires (both single strand and Multi strand) on a general purpose PCB taking due precautions.

### **Reference books:**

1. Getting Started in Electronics by Forrest.M.Mims (e-book)

### **E-Links:**

1. [www.electronicshub.org/tutorials](http://www.electronicshub.org/tutorials)

## SC-109 - BASIC SCIENCE LAB

Course Title	Basic Science Lab	Course Code	SC-109
Semester	I	Course Group	Practical
Teaching Scheme in Pds/Hrs(L:T:P)	1:0:2	Credits	1.5
Type of course	Tutorial & Practical	Total Contact Periods	45
CIE	60 Marks	SEE	40 Marks

### Physics Lab

**Pre requisites:** Knowledge of basic concepts of basic High school science and basic mathematics

**Course objectives:** To provide practical knowledge about the basics of Physics instrumentation and calculations/measurements.

Course Outcomes	
CO1	Understand Vernier caliper principle and calculate accurate measurement of lengths and volumes of various objects
CO2	Understand Screw Gauge principle and calculate accurate measurement of thickness of various thin objects
CO3	Understand vectors and resultant of vectors and verify Parallelogram law of forces and Triangle law of forces
CO4	Understand the concept of viscosity and calculate Coefficient of viscosity of a liquid by capillary method
CO5	Verify Boyle's law employing Quill tube.

CO	PO1	PO2	PO3	PO4	PO5	PO6	PO7
CO1	3			-	-	1	1
CO2	3			-	-	1	1
CO3	3			-	-	1	1
CO4	3			-	-	1	1
CO5	3			-	-	1	1
	3					1	1

**Learning outcomes**

On successful completion of the course, the student will have ability to:

1. Determine the volumes of objects like cylinder, sphere and piece of pipe.
2. Determine thickness /diameter of small objects like glass plate and wire.
3. Verify the parallelogram law and triangle law of forces.
4. Determine the viscosity of liquid using capillary method
5. Verify Boyle's law employing Quill tube.

**Course Delivery:**

The course will be delivered through lectures, class room interaction, group discussions, graded exercises, demonstration and practice.

**Tutorial: 1Periodd /Experiment:**

1. Introduction to Physics practical and its importance, safety precautions in maintenance of equipment in the laboratory.
2. Maintenance of apparatus and equipment.
3. Follow of Do's and Don'ts.
4. Maintenance of data in manual and record book.
5. Write the procedure of the experiment before the commencement of each experiment.
6. Strictly following of instructions given from time to time by the lecturer-in-charge.
7. Demonstration of each experiment by the lecturer in charge.

**Conduction of experiments: 2 periods/Experiment.**

Student must perform experiment individually under the supervision of the lecturer-in charge.

<b>EXAMINATION &amp; EXPERIMENTS</b>		
<b>S.NO</b>	<b>EXAMINATION</b>	<b>EXPERIMENTS</b>
1	MIDSEM-I	EXPERIMENT NO 1 & 2
2	MIDSEM-II	EXPERIMENT NO 3 & 4
3	SEMESTER END EXAMINATION	EXPERIMENT NO 1,2,3,4 and 5

<b>Scheme of Valuation of SEE</b>		
<b>S.No</b>	<b>Particulars</b>	<b>Marks</b>
1.	Objective/Aim	01
2.	Apparatus/Equipment	02
3.	Observations	02
4.	Principle including formula	02
5.	Experiment (Tabular form, readings, etc)	05
6.	Calculation and Result	05
7.	Viva Voce	03
	<b>Total</b>	<b>20</b>

References:

1. Basic Applied Physics – R.K. Gaur
2. Laboratory manual for class XI and XII – NCERT

## Chemistry Lab

### **Prerequisite:**

Knowledge of basic concepts of chemistry of secondary education.

### **Course Objectives:**

To provide practical knowledge about the basics of preparation of chemical solutions and volumetric analysis of chemical compounds.

### **Course Outcomes:**

On successful completion of the course, the student will have ability to attain CO:

<b>Course Outcome</b>	
<b>CO1</b>	Prepare the standard solution.
<b>CO2</b>	Estimate the amount of the HCl in the given sample of solutions
<b>CO3</b>	Estimate the amount of the NaOH in the given sample of solutions.
<b>CO4</b>	Estimate the amount of the H <sub>2</sub> SO <sub>4</sub> in the given sample of solutions.
<b>CO5</b>	Determine the hardness of water in the given sample.

<b>CO</b>	<b>PO1</b>	<b>PO2</b>	<b>PO3</b>	<b>PO4</b>	<b>PO5</b>	<b>PO6</b>	<b>PO7</b>
CO1	3	-	-	1	-	1	1
CO2	3	-	-	-	-	1	1
CO3	3	-	-	-	-	1	1
CO4	3	-	-	-	-	1	1
CO5	3	-	-	-	2	1	1

### **Course Delivery:**

The course will be delivered through lectures, classroom interaction, group discussion, demonstration and practicals.

## **Conduction of experiments: Lecture 1 period + Experiment 2 periods.**

Student must conduct experiment individually under the supervision of the staff-in-charge.

### **Lecture and Demonstration: 1 Period**

1. Introduction of chemistry practical and its importance, safety precautions in maintenance of cleanliness and orderliness of chemicals in the laboratory.
2. Maintenance of apparatus and equipment.
3. Follow of Do's and Don'ts.
4. Maintenance of data in record book.
5. Write the procedure of the experiment before the commencement of each experiment.
6. Strict following of instructions given from time to time by the staff-in-charge.
7. Demonstration of each experiment by the staff in charge.

### **Course Content**

#### **Volumetric Analysis: (22.5 Periods)**

#### **Volumetric Analysis by Titrimetric Method:-**

Volumetric Analysis - Titration – Standard Solutions - Concentration of solutions - Indicators - Acid base indicators - Selection of indicators - Endpoint of titration- Neutralization.

#### **List of experiments:**

1. Preparation of 0.05M sodium carbonate solution.
2. Estimation of hydrochloric acid present in 250 ml of solution by using standard sodium carbonate solution.
3. Estimation of sodium hydroxide present in 250ml of solution by using standard hydrochloric acid solution.
4. Estimation of sulphuric acid present in 250ml of solution by using standard sodium hydroxide solution.
5. Determination of total hardness of water sample by 0.02N EDTA solution.

#### **Specific Learning Outcomes**

#### **Upon completion of the course, the student will have ability to**

1. Prepare standard sodium carbonate solution and dilute to desired concentration.
2. Estimate hydrochloric acid present given volume of solution by using standard sodium carbonate solution.
3. Estimate sodium hydroxide present in the given volume of solution by using standard hydrochloric acid solution.
4. Estimate sulphuric acid present in the given volume of solution by using standard sodium hydroxide solution.
5. Determine the total hardness of water sample by using 0.02N EDTA solution.

**Reference Books:**

1. Vogel's Inorganic Qualitative and Quantitative Analysis.
2. Practical chemistry by O.P.Pande & others.
3. Qualitative and quantitative analysis by Alex.

<b>EXAMINATION &amp; EXPERIMENTS</b>		
<b>S.NO</b>	<b>EXAMINATION</b>	<b>EXPERIMENTS</b>
1	MIDSEM-I	Experiment No. 1 & 2
2	MIDSEM-II	Experiment No. 3 & 4
3	SEMESTER END EXAMINATION	Experiment No. 1,2,3,4 and 5

<b>Scheme of Valuation for MID I &amp; II and SEE</b>		
<b>Sl. No.</b>	<b>Particulars</b>	<b>Marks</b>
<b>1</b>	Identification of apparatus/equipment/chemical compounds/tools/etc.	2
<b>2</b>	Writing Principle and Procedure	5
<b>3</b>	Experiment and Observations	6
<b>4</b>	Calculation and Results	4
<b>5</b>	Viva-voice	3
<b>Total</b>		<b>20</b>

**BOARD DIPLOMA EXAMINATION, (C-21)**  
**MIDSEM – I**  
**FIRST SEMESTER EXAMINATION**  
**SC-109 - BASIC SCIENCE LAB**

**TIME: 1 Hour**

**TOTAL MARKS: 20**

---

- Instructions:** (1) Answer both PART-A AND PART-B on separate answer sheets.
- (2) Each question carries **TEN** marks.

**PART-A (PHYSICS LAB)**

*Perform ONE experiment allotted by the examiner.*

1 x 10 = 10

1. Find the volume of given sphere using Vernier caliper.
2. Find the volume of given cylinder using Vernier caliper.
3. Find the volume of given piece of pipe using Vernier caliper
4. Determine the thickness of given glass plate using Screw gauge.
5. Find the cross sectional area of given wire using Screw gauge.

**PART-B (CHEMISTRY LAB)**

*Perform ONE experiment allotted by the examiner.*

1 x 10 = 10

1. Prepare 250 ml of 0.05M sodium carbonate solution.
2. Estimate the amount of hydrochloric acid present in 500 ml of the given solution using 0.02M sodium carbonate solution.
3. Estimate the amount of hydrochloric acid present in 250 ml of the given solution using 0.05M sodium carbonate solution.

**BOARD DIPLOMA EXAMINATION, (C-21)**  
**MIDSEM – II**  
**FIRST SEMESTER EXAMINATION**  
**SC-109 - BASIC SCIENCE LAB**

**TIME: 1 Hour**

**TOTAL MARKS: 20**

---

**Instructions:** (1) Answer both PART-A AND PART-B on separate answer sheets.

(2) Each question carries **TEN** marks.

**PART-A (PHYSICS LAB)**

*Perform ONE experiment allotted by the examiner.*

1 x 10 = 10

1. Verify parallelogram law of forces.
2. Verify triangle law of forces
3. Determine coefficient of viscosity of water using capillary method.

**PART-B (CHEMISTRY LAB)**

*Perform ONE experiment allotted by the examiner.*

1 x 10 = 10

1. Estimate the amount of NaOH present in 500 ml solution using 0.02M HCl solution
2. Find the Molarity and estimate the amount of Sulphuric acid present in 250 ml solution using 0.01M NaOH solution.

**BOARD DIPLOMA EXAMINATION, (C-21)**  
**SEMESTER END EXAMINATION**  
**FIRST SEMESTER EXAMINATION**  
**SC-109 - BASIC SCIENCE LAB**

Time: 2 Hours]

[Total Marks: 40

---

**Instructions:** (1) Answer both PART-A AND PART-B on separate answer sheets.  
(2) Each question carries **TWENTY** marks.

**PART-A (PHYSICS LAB)**

*Perform ONE experiment allotted by the examiner.*

1 x 20 = 20

1. Find the volume of given sphere using Vernier caliper.
2. Find the volume of given cylinder using Vernier caliper.
3. Find the volume of given piece of pipe using Vernier caliper
4. Determine the thickness of given glass plate using Screw gauge.
5. Find the cross sectional area of given wire using Screw gauge.
6. Verify parallelogram law of forces
7. Verify triangle law of forces.
8. Determine coefficient of viscosity of water using capillary method.
9. Verify Boyle's law using Quill tube.

**PART-B (CHEMISTRY LAB)**

*Perform ONE experiment allotted by the examiner.*

1 x 20 = 20

10. Prepare 250 ml of 0.05M sodium carbonate solution.
11. Estimate the amount of hydrochloric acid present in 500 ml of the given solution using 0.02M sodium carbonate solution.
12. Estimate the amount of hydrochloric acid present in 250 ml of the given solution using 0.05M sodium carbonate solution.
13. Find the Molarity and estimate the amount of NaOH present in 100 ml of the given solution using 0.01M HCl solution.
14. Estimate the amount of Sulphuric acid present in a litre of solution using 0.01M NaOH solution.
15. Determine the total hardness of the given water sample using 0.02N EDTA solution

## CS-110 - Basic Computer Science Lab

Course Title	Basic Computer Science Lab	Course Code	CS-110
Semester	I	Course Group	Practical
Teaching Scheme in Periods (L:T:P)	1:0:2	Credits	1.5
Methodology	Lecture +Tutorial	Total Contact Periods	45
CIE	60 Marks	SEE	40 Marks

**Pre-requisite:** The students should have basic knowledge of and basic knowledge of using computer

### COURSE OUTCOME

CO1	Creating and saving a document, Formatting of text in MS-WORD
CO2	Spell checking, Mail merging and Printing of Documents in MS-WORD
CO3	Creating and Saving a presentation, inserting text and pictures & Formatting the text and pictures, Slide transition and Animation effects in MS-POWER POINT
CO4	Building Worksheet & Charts In Ms-Excel and Printing Of Worksheet
CO5	Creating Database, Tables, Forms, Queries, Reports In Ms-Access

### Course Contents

#### 1. Unit-I: Creating, Saving a document, Formatting of text in MS-WORD

**Duration: 5 hrs**

- MS\_WORD - Creating and saving a document, Formatting of text

#### 2. Unit-II: Spell checking, Mail merging and Printing of Documents in MS-WORD MS Word

**Duration: 10 hrs**

- MS-WORD - Spell Checking - Mail merging - Printing of Documents

#### 3. Unit-III: Creating and Saving a presentation in MS Powerpoint and Slide transition and Animation effects

**Duration: 10 hrs**

- MS-POWER POINT - Creating and saving a presentation - Inserting text and pictures - Formatting the text and pictures- MS-POWER POINT - Effects of slide transition - Animation effects - Slide show & views of slides

#### **4. Unit-IV Building & Charts in MS-Excel and Printing Of Worksheet**

**Duration: 10 hrs**

- Building Worksheets – Building Charts, Printing EXCEL Worksheet

#### **5. Unit-V Creating Database, Tables, Queries, Forms ,Reports & Printing**

**Duration: 10 hrs**

- Creating Table, Viewing(ACCESS) – Creating Forms – Creating Queries and Viewing Database
- Creating of ACCESS Reports – Printing of ACCESS Tables, Forms, Reports

### **Specific Learning Outcomes:**

#### **1.0 Practice Operation of MS-Word.**

- 1.1 Demonstrate starting MS word.
- 1.2 Identify the word screen elements.
- 1.3 Identify the tool bars on the screen.
- 1.4 Demonstrate loading different tool bars for their functionality.
- 1.5 Identify the drop down menus of the main menu and their functionality.
- 1.6 Demonstrate creating a sample text.
- 1.7 Demonstrate text formatting.
- 1.8 Demonstrate page formatting.
- 1.9 Demonstrate selecting, deselecting the text from menu and Copying.
- 1.10 Demonstrate importing text from other packages.

#### **2.0 Spell checking, Mail merging and Printing of Documents in MS-WORD**

- 2.1 Demonstrate search and replace of text.
- 2.2 Demonstrate spell checking.
- 2.3 Demonstrate creating tables.
- 2.4 Demonstrate mail merging of documents.
- 2.5 Demonstrate printing documents, merge printing of documents.
- 2.6 Demonstrate word procedure for importing figures, charts from other installed software.

#### **3.0 Practice operation of MS-Power Point and Slide transition and Animation effects.**

- 3.1 Demonstrate starting MS Power Point.

- 3.2 Identify the opening screen elements.
- 3.3 Identify the tool bars in the opening screen.
- 3.4 Demonstrate the selection of the methods of creating a new presentation.
- 3.5 Identify the different Auto Layouts of a slide.
- 3.6 Demonstrate creating a new slide
- 3.7 Demonstrate inserting a new slide.
- 3.8 Demonstrate slide transition effects.
- 3.9 Demonstrate a slide show.
- 3.10 Demonstrate animation effects.
- 3.11 Demonstrate creating an organization chart.
- 3.12 Identify the different slide views.

#### **4.0 Building Worksheets & Charts in MS-Excel**

- 4.1 Start EXCEL from the start
- 4.2 Identify the various parts of the window.
- 4.3 Identify the tabs and groups in ribbon layout
- 4.4 Identify and customizing the quick access toolbar
- 4.5 Identify the office button and commands of the drop down menu.
- 4.6 Practice loading of the existing worksheet or create a new worksheet.
- 4.7 Practice entering into the worksheet.
- 4.8 Practice formatting the cells.
- 4.9 Practice formatting the texts in the cells.
- 4.10 Practice changing the height and width of the cells.
- 4.11 Practice freezing the rows, columns.
- 4.12 Practice splitting the screens.
- 4.13 Enter formulas into the cells.
- 4.14 Enter formulas with built in functions.
- 4.15 Create a range name for the cells for group operations.
- 4.16 Create graph for the data in the worksheet.

#### **5.0 Creating Database, Tables, Queries and Forms**

- 5.1 Practice loading Ms Access from the start menu.
- 5.2 Create a database table using Database Wizard.
- 5.3 Enter data into the table.
- 5.4 Edit data in the table.

- 5.5 View data from the database.
- 5.6 Design a query.
- 5.7 View data using the query.
- 5.8 Demonstrate creating Forms.
- 5.9 View the database through Forms.
- 5.10 Practice navigating through the database through Forms.
- 5.11 Practice creating Custom Form using Forms Wizard.
- 5.12 Practice creating Reports using the Report Wizard.
- 5.13 Practice printing the tables, forms and reports.

## **EXERCISES**

1. Create and save a document using MS WORD.
2. Format the Text document.
3. Change the page set-up and Insert Header/Footer.
4. Spell checking in the document.
5. Print the document.
6. Create main document and data file for mail merging.
7. Print the document with mail merging.
8. Create a table in the document.
9. Add row, column to a table.
10. Create and save a new presentation using MS Power Point.
11. Choose Auto Layout for a new slide.
12. Inserting text and pictures into a blank slide.
13. Inserting new slides into the presentation.
14. Applying slide transition effects.
15. Demonstrate a slide show.
16. Set animation to text and pictures in a slide.
17. Set the sounds, order and timing for animation.
18. Create and save a new work book in Excel
19. Operating Mouse to selecting tabs, groups, cells, group of cells
20. Entering Data into Worksheet
21. Editing of Worksheet
22. Formatting the text in the cells
23. Formatting the numbers in the cells.

24. Changing the height and width of cells.
25. Freezing Titles, splitting screen
26. Enter formulae for calculation in the cells.
27. Copying the formula over a range of cells.
28. Inserting built-in functions in to the cells.
29. Create graphs for the data using Chart Wizard.
30. Practice Data Forms in Excel.
31. Printing of worksheet
32. Creating Tables using wizard in Access
33. Creating Tables using Design View in Access.
34. Entering Data into tables
35. Viewing the data in table.
36. Creating a new query using wizard.
37. Creating a new query using design view.
38. Viewing the data using a Select Query.
39. Updating the data in table using Update Query.
40. Linking two Tables on Relational Aspect.
41. Create forms using Form Wizard.
42. Create reports using Report Wizard.
43. Printing the tables, forms and reports

### **Suggested Student Activities**

1. Student visits Library to refer to Manual for the specifications
2. Student inspects the available equipment in the Lab to identify the components
3. Visit nearby Industry to familiarize with fabrication techniques
4. Analyze the connections in the UPS available in the Institution facility
5. Quiz , Group discussion, Surprise test

### **RECOMMENDED BOOKS:**

1. Teach yourself Office 2007 for Windows – Coray Sandler, Tom Badgett, Jan Weingarten, BPB Publications.
2. The ABC s of MS Office 2007– Guy Hard-Davis, BPB Publications.
3. Working in MS Office - Ran Mansfield, Tata McGraw Hill Publications.

### Student E-Learning reference

1. <https://www.tutorialspoint.com/word/index.htm>
2. <https://www.tutorialspoint.com/powerpoint/index.htm>

### CO / PO MAPPING MATRIX

	<b>COURSE OUTCOME</b>	<b>CL</b>	<b>Linked PO</b>	<b>Teaching Hrs</b>
CO1	Creating and saving a document, Formatting of text in MS-WORD	R/U/A	1,2,3,4,7	5
CO2	Spell checking, Mail merging and Printing of Documents in MS-WORD	R/U/A	1,2,3,4,7	10
CO3	Creating and Saving a presentation, inserting text and pictures & Formatting the text and pictures and Slide transition and Animation effects in MS-POWER POINT	R/U	1,2,3,4,7	10
C04	Building Worksheet & Charts In Ms-Excel and Printing Of Worksheet	R/U/A	1,2,3,4,7	10
C05	Creating Database, Tables, Forms, Queries, Reports In Ms-Access	R/U/A	1,2,3,4,7	10

MODEL PAPER OF **MID SEM- I** EXAM

TIME: 1 hr

MARKS: 20

ANSWER ANY ONE QUESTION. EACH QUESTION CARRIES TWENTY MARKS.

20 x 1 = 20

1. Demonstrate Starting MS word and identify the word screen elements.
2. Draw and explain the groups and commands in Home tab under ribbon in Ms word.
3. Demonstrate text formatting in Ms word.
4. Demonstrate procedure for checking of spelling and grammar using dictionaries.
5. Demonstrate paragraph formatting in Ms word.
6. Draw and explain the groups and commands in page layout tab under ribbon in Ms word.
7. Demonstrate page formatting in Ms word.
8. Demonstrate procedure for creating Mail merging process in Ms word.
9. Demonstrate creating of table and adding rows and columns to the existing table in Ms word.
10. Demonstrate finding and replacing of text & searching for a bookmark.
11. Demonstrate starting of MS Power Point and identify the opening screen elements.
12. Draw and explain the groups and commands in Home tab under ribbon in MS Power Point.
13. Demonstrate different Auto Layouts of a Slide in MS Power Point.
14. Demonstrate Slide Transition effects in Ms Power Point.
15. Demonstrate different Animation effects in Ms Power Point.
16. Draw and explain the groups and commands in Animations tab under ribbon in MS Power Point.
17. Demonstrate different Slide views in MS Power Point.
18. Draw and explain the groups and commands in Review tab under ribbon in MS Power Point.
19. Demonstrate inserting and formatting of text and pictures in MS Power Point.

MODEL PAPER OF **MID SEM- II EXAM**

TIME: 1 hr

MARKS: 20

ANSWER ANY ONE QUESTION. EACH QUESTION CARRIES TWENTY MARKS. 20  
x 1 = 20

1. Write procedure to open Excel window and Draw and label the parts in Excel window.
2. Draw and Write about groups and commands under Formulas tab under the ribbon in MS-Excel.
3. Write procedure to format the text in the cells.
4. Write procedure to enter formulas with built in functions.
5. Write procedure for creating chart in MS-excel.
6. Write Procedure for formatting numbers in MS-Excel.
7. Write procedure for writing criteria and extract the data.
8. Write procedure for printing of a worksheet.
9. Write procedure for formatting of chart in Ms-excel.
10. Write procedure to jump to different workbooks & import worksheet from different workbook.
11. Write procedure to create a database.
12. Write procedure to create a table using design view.
13. Write procedure to create form using forms wizard.
14. Write procedure for creating reports using report wizard.
15. Write procedure for creating a Custom Form.
16. Write the procedure to create custom reports.
17. Write the procedure to print active sheet.
18. Write the procedure for Printing of reports.
19. Draw and explain the groups and commands in create tab under ribbon in Ms access.
20. Write the procedure for creating Filter by form.

## MODEL PAPER OF END SEMESTER EXAM

TIME: 2hr

MARKS : 40

ANSWER ANY ONE QUESTION. EACH QUESTION CARRIES TWENTY MARKS.

20 x 1 = 20

1. Write procedure for Creating and saving a document and draw and label the different parts of opening screen elements in Ms word.
2. Draw and explain the groups and commands in Home tab under ribbon in MS Power Point.
3. Write procedure for applying sounds, order, timing and effects of animation in a presentation.
4. Write procedure for character formatting in Ms word.
5. Draw and explain the groups and commands in Home tab under ribbon in Ms word.
6. Write procedure for creating main document and data file for mail merging.
7. Write procedure for page formatting in Ms word.
8. Write procedure for checking spelling and grammar using dictionary in Ms word.
9. Write procedure for printing of document in Ms word.
10. Draw and explain the groups and commands in Animations tab under ribbon in MS Power Point.
11. Write procedure to open Excel window and Draw and label the parts in Excel window.
12. Draw and Write about groups and commands under Formulas tab under the ribbon in MS-Excel.
13. Write procedure to format the text in the cells.
14. Write procedure to enter formulas with built in functions.
15. Write procedure for creating chart in MS-excel.
16. Write Procedure for formatting numbers in MS-Excel.
17. Write procedure for writing criteria and extract the data.
18. Write procedure for printing of a worksheet.
19. Write procedure for formatting of chart in Ms-excel.

20. Write procedure to jump to different workbooks & import worksheet from different workbook.
21. Write procedure to create a database.
22. Write procedure to create a table using design view.
23. Write procedure to create form using forms wizard.
24. Write procedure for creating reports using report wizard.
25. Write procedure for creating a Custom Form.
26. Write the procedure to create custom reports.
27. Write the procedure to print active sheet.
28. Write the procedure for Printing of reports.
29. Draw and explain the groups and commands in create tab under ribbon in Ms access.
30. Write the procedure for creating Filter by form.

Record book :- 10 marks

Viva-voce:- 10 marks

## ES-111-SKILL UPGRADATION

Course Title	Skill Upgradation	Course Code	ES-111
Semester	I	Course	Core
Teaching Scheme in periods	0:0:8	Credits	2.5
Methodology	Activities	Total Contact	120
CIE	Rubrics	SEE	NIL

### Basic English – Skills Upgradation

#### TASK:

**LEVEL 1:** Collection of material for learning skills

**LEVEL2:** Analysis of the material

**LEVEL 3:** Practice the activities

**LEVEL 4:** Assessment of the skills acquired

#### Activity before the activities:

*Collect the material useful for learning Listening, Speaking, Reading, Writing (LSRW skills), Grammar and Vocabulary.*

- 1. Collect newspaper clippings, books, puzzles, pictures, audio and video programmes in English.*
- 2. Talk to your classmates, seniors, alumni, teachers, successful people in job interviews and celebrities.*
- 3. Visit libraries to gather information.*
- 4. Visit useful websites for acquiring language learning skills.*

#### Activities:

1. Collect / Go through the different kinds of dictionaries and find out the differences.
  - a) List out the English words which are originated from Telugu, Hindi, Sanskrit and other Indian languages.
  - b) Prepare a list of technical words related to your branch.
  - c) Prepare the list of Homonyms, Homophones. Heteronyms, Heterophones and Capitonyms.
2. Collect the vocabulary building games and activities. Practice them individually, in pairs and groups.
3. Learn different kinds of reading a text. Practice various kinds of reading material.

4. Find out the differences between reading aloud and silent reading. Identify the advantages and disadvantages of speed reading.
5. Conduct a survey on the need for English. Talk to your classmates or seniors and find out the difficulties while learning English.
6. Practice dialogues on
  - a) Feelings
  - b) Likes & dislikes
  - c) Requests
  - d) Obligations(Dramatize the dialogues)
7. Introduce yourself through a line up activity or inner and outer circle activity.
8. Introduce tenses:
  - a) Write the diary using present tense.
  - b) Write an anecdote in past tense.
  - c) Prepare the weather forecast for the next week in future tense.
9. Observe the picture / photo and describe the persons, places and things using the describing words and prepositions.
10. Role play: Interview a celebrity using 'wh' and 'yes/no' questions.
11. Identify what is there in the bag using 'yes/no' questions.
12. Arrange the jumbled sentences in an order to make a meaningful paragraph.
13. Write a paragraph on your goals.
14. Write a letter to God / a celebrity.
15. Collect the letters written by great leaders, celebrities and officers.

Note: The above activities are indicative. The teacher may assign any other activity relevant to the skills introduced in the semester.

### COURSE OUTCOMES

<b>No.</b>	At the end of the course, the students will have the ability to:
<b>101.1</b>	Use a dictionary and acquire vocabulary for social interaction.
<b>101.2</b>	Comprehend, identify main ideas, make inferences, visualize, and answer questions. Analyze and evaluate the written material.
<b>101.3</b>	Speak and write grammatically correct sentences, communicate effectively, express their likes, dislikes, feelings, make requests, express obligations and introduce themselves.
<b>101.4</b>	Use verbs in the different tenses according to the situations. Use Voice to express an action clearly
<b>101.5</b>	Describe people and objects, ask questions, use prepositions and write grammatically correct sentences.
<b>101.6</b>	Convey ideas in the form of paragraphs and letters

### CO-PO Matrix

<b>CO</b>	<b>PO 1</b>	<b>PO 2</b>	<b>PO 3</b>	<b>PO 4</b>	<b>PO 5</b>	<b>PO 6</b>	<b>PO 7</b>	<b>Mapping POs</b>
<b>101.1</b>	-	-	-	-	3		3	5,7
<b>101.2</b>	-	-	-	-	3	2	3	5,6,7
<b>101.3</b>	-	-	-	-	3	3	3	5,6,7
<b>101.4</b>	-	-	-	-	2	2	3	5,6,7
<b>101.5</b>	-	-	-	-	2	2	3	5,6,7
<b>101.6</b>		-	--	--	2		3	5,7



## I SEMESTER

### SKILL UPGRADATION IN - BASIC ENGINEERING MATHEMATICS

#### ACTIVITY ASSESSMENT Steps

1. Mathematical concepts
2. Procedure
3. Explanation
4. Working with others
5. Mathematical errors

#### ACTIVITIES

1. Prepare a presentation to explain Logarithms.
2. Prepare a list of articles purchased from a super market and arrange in a matrix form to Compute the total amount using matrix multiplication.
3. Prepare a presentation to resolve a Partial fraction into simpler fractions.
4. Prepare a presentation stating the applications of Trigonometry.
5. List the methods to solve system of equations using Matrices and Determinants. Describe their features.
6. Visit the library, refer books on Mathematics and collect the details related to 2 Mathematicians.
7. Prepare a presentation to solve a triangle ABC in different cases.

#### CO / PO - MAPPING OF ACTIVITIES

CO	PO1	PO2	PO3	PO4	PO5	PO6	PO7	PO8	PO9	PO10
CO1	3	2	2	1			1	2	2	3
CO2	3	2	2	1	1		1	2	2	3
CO3	3	2	2	1			1	2	2	3
CO4	3	2	2	1			1	2	2	3
CO5	3	2	2	1			1	2	2	3
CO6	3	2	2	1			1	2	2	3
CO7	3	2	2	1			1	2	2	3



## SKILL UPGRADATION – C21 BASIC PHYSICS

### TASK

**LEVEL 1: Concept, Ethical Data, Materials, Source (Library/internet/others)**

**LEVEL 2: Methodology/procedure**

**LEVEL 3: Analysis/experiment**

**LEVEL 4: Interpretation/inference/evaluation.**

***Bridge activity: - Visiting your college Library:***

*(A) Prepare a list of available reference books in Physics with details such as author, publisher, edition etc.*

*(B) Prepare a list of Physics/Science journals, magazines, monographs with details.*

*(C) Prepare a log book of your visits to college library with brief description.*

***Activities:-***

1. Discover some physical equations and apply principle of homogeneity.
2. Visit your College Physics laboratory. Collect equal amounts (mass in gm) of water and mercury. Calculate the density of each in CGS units. Express them in SI system of units using dimensional analysis. Infer the result.
3. Identify the bodies which have rolling objects like wheels, ball bearings. Prepare a chart with drawings and explain the importance of rolling friction.
4. Identify the objects where you apply various methods of reducing friction. Make each method as a module to one individual. Integrate all modules and generate a chart with brief explanation by the use of drawings.
5. Take two vectors with varying angles of inclination. Find the resultant using triangle law of vector addition by drawing the vectors in each case on a graph paper. Draw the conclusions. Correlate the result using parallelogram law of vector addition.
6. Three forces  $F_1$ ,  $F_2$  and  $F_3$  are acting on a body with angles  $\theta_1$ ,  $\theta_2$ , and  $\theta_3$  with the horizontal respectively. Calculate the resultant force acting on that body. Draw the diagram.
7. Survey the places where curved paths are banked. Take photographs and reconstruct on the chart. Prepare a report.
8. Verify Hooke's Law by performing experiment using weights, spring and ruler.
9. Explore the internet. Prepare a power point report on surface tension and wetting, viscosity.
10. Debate on Green house effect and global warming. Justify the advantage of green house effect. Prepare a video clip and power point report with diagrams.
11. Design a mini wind mill/solar cooker/biomass plant as an application of conversion of energy.

12. Construct a model thermometer having centigrade scale, Fahrenheit and absolute scale with the help of available simple objects. Formulate the method of development.

*NOTE: The above activities are indicative. The teacher may assign any other activity relevant to the course based on resources available.*

Course Outcomes (CO)		Linked Pos	Activity Hours
CO1	Apply principle of homogeneity	PO1, PO2	3
CO2	Convert unit from one system to other system using dimensions	PO1, PO2, PO3	3
CO3	Prepare a chart with drawings explaining the importance of friction	PO1, PO2, PO7	3
CO4	Prepare a chart on reducing friction	PO1, PO2, PO4, PO5, PO7	3
CO5	Triangle law of vector addition - graphical analysis – correlation with parallelogram law of vector addition	PO1, PO4,	3
CO6	Calculate resultant force by component method	PO1, PO2, PO4	3
CO7	Banking of roads – practical observations	PO1, PO2, PO5	3
CO8	Verify Hooke's law with simple materials	PO1, PO2, PO3, PO4	3
CO9	Power point report on surface tension and wetting, viscosity by exploring internet	PO1, PO2, PO7	3
CO10	Debate on Green house effect and global warming. Advantage of green house effect - justification. Prepare a video clip and power point report with diagrams.	PO5, PO6, PO7	3
CO11	Design a mini wind mill/solar cooker/biomass plant as an application of conversion of energy-working models.	PO5, PO6, PO7	3
CO12	Construct a model thermometer having centigrade scale and absolute scale. Formulate the development.	PO1, PO2, PO4	3



## **SC-104 - GENERAL ENGINEERING CHEMISTRY**

### **Suggested Skill Upgradation Activities**

#### **Activity Assessment Steps:**

**Level-1: Concept, Data collection and summarization, Material etc**

**Level-2: Prepare Chart, explain the process, perform the experiment etc, and prepare a report etc**

**Level-3: Oral or power point presentation of the activity.**

**Level-4: Submission of report.**

#### **Activity – 1**

Prepare a chart or model of different types of orbitals and electronic configuration.

#### **Activity – 2**

Prepare the models/ charts on ionic and covalent bonding.

#### **Activity – 3**

Prepare and study the physical properties of True Solution, Colloidal Solution, and Suspension.

#### **Activity – 4**

Study of the acidic, basic or neutral nature of water sample collected from various sources.

#### **Activity – 5**

Compare the renewable and non-renewable energy sources.

#### **Activity – 6**

Study and analysis of ecosystem (lake, pond etc) existing in your surroundings.

#### **Activity – 7**

Study of bio diversity in your surroundings.

#### **Activity – 8**

Study and report the importance of forest resources.

#### **Activity – 9**

Study and report the importance of osmosis and reverse osmosis.

#### **Activity – 10**

Explain the method of purification of drinking water adopted at your residence.

#### **Activity – 11**

Preparation of the models/ charts on the softening of water by different methods and comparison.

#### **Activity – 12**

Study of electrolytes and non-electrolytes

**Note: Any other skill upgradation activity related to the course may be taken up.**

### Mapping of POs to Skill Upgradation Activities

S.No	Name of the activity	Linked POs
1	Prepare a chart or model of different types of orbitals and electronic configuration.	1, 6,7
2	Prepare the models/ charts on ionic and covalent bonding.	1, 6,7
3	Prepare and study of physical properties of True Solution, Colloidal Solution, and Suspension.	1,4, 6,7
4	Study of the acidic, basic or neutral nature of water sample collected from various sources.	1,4, 6,7
5	Compare the renewable and non renewable energy sources.	1, 5, 6,7
6	Study and analyze the ecosystem (lake, pond etc) existing in your surroundings	1, 5, 6,7
7	Study of bio diversity in your surroundings	1, 5, 6,7
8	Study and report the importance of forests resources.	1,5, 6,7
9	Study and report the importance of osmosis and reverse osmosis.	1, 6,7
10	Explain the method of purification of drinking water adopted at your residence.	1, 6,7
11	Preparation of the models/ charts on the softening of water by different methods and comparison.	1, 6,7
12	Study of electrolytes and non-electrolytes	1, 6,7

**Method of evaluation of the student activities ( Rubrics)**

**Model Rubrics**

S. No	Sub activity	Performance Level (Score)			
		Excellent (4)	Good (3)	Satisfactory (2)	Need improvement (1)
1	Level-1 (Data and Material collection)	All materials and data required for the activity were accurately prepared based on the data collected independently	Almost all materials and data required for the activity were accurately prepared based on the data collected independently	The materials and data required for the activity were accurately prepared based on the data collected with the help of teacher.	The materials and data required for the activity were inaccurately prepared .
2	Level-2 (Chart, Model, Experiment or Study)	Procedures were outlined in a step-by-step fashion that could be followed by anyone & performed the activity effectively.	Procedures were outlined in a step-by-step fashion, require explanation & performed the activity effectively.	Procedures that outlined were complete with 1 or 2 gaps and require explanation & performed the activity normally	Procedures that outlined were not sequential, & performed the activity in a poor way
3	Level-3 ( Oral or Power point presentation)	Presented/ explained the information about the activity in logical, interesting sequence with attractive visuals or diagrams.	Presented/ explained the information about the activity in logical sequence with visuals or diagrams.	Presented/ explained the information about the activity in logical sequence with less visuals or diagrams.	Presented/ explained the information about the activity without sequence and visuals or diagrams.
4	Level-4 (Submission of Report)	Provided a detailed conclusion/ summary clearly based on the data and activity	Provided a conclusion / summary clearly based on the data and activity	Provided a conclusion/ summary less effectively	Conclusions /summary was not relevant.

**Note: The above rubrics are indicative. Separate rubrics may be prepared according to the activity. Minimum passing score is 2.5.**

## **SKILL UPGRADATION ACTIVITIES**

1. Visit the College library and prepare a list of at least 10 text books available in the library with author name and publishing company for each subject of the semester. The student should submit a handwritten report.
2. Prepare a presentation explaining the concepts of Heat and Thermodynamics in the subject of Physics.
3. Prepare a model to carry out the purification of water supplied in the college
4. Listen to passages/ conversations/dialogues/speeches and answer the questions to improve the listening skills.
  
5. Read out a selected text from a newspaper depicting an incident to enhance the reading skills
6. Read aloud the selected text with proper pronunciation and intonation to improve the accent of the language.
7. Perform the following vocabulary games:
  - i) Cross words
  - ii) Guessing the missing letter
  - iii) Dumb charades
8. Visit the library to refer Standard Books on Mathematics and collect related material pertaining to a concept in mathematics.
9. Visit the library to refer Standard Books on Mathematics and collect related material pertaining to a concept in Physics.
10. Visit the library to refer Standard Books on Mathematics and collect related material pertaining to a concept in Chemistry.
11. Student observes the available equipment in the Physics Laboratory and prepares a hand written report on functioning of the equipment and accessories along with the details regarding repairs to be carried out.
12. Student observes the available equipment in the Chemistry Laboratory to familiarize with the methods of preparing standard solutions for specific experiments and prepares a hand written report.
13. Do a power point presentation on Ohm's law, Kirchhoff's law and Faraday's law. Documents have to be maintained as a record.
14. Do Market survey on List of Electrical equipment in your home available and collect the information like name of the equipment specifications, Price etc. The student should submit a handwritten report.
15. Do Market survey on List of Electronic equipment in your home available and collect the information like name of the equipment specifications, Price etc. The student should submit a handwritten report