

C21_ Curriculum

DIPLOMA IN CHEMICAL ENGINEERING



OFFERED BY

STATE BOARD OF TECHNICAL EDUCATION & TRAINING,

TELANGANA: HYDERABAD

I SEMESTER

	Course Code	Course Name	Teaching Scheme					Examination Scheme							
			Instruction periods per week			Total Periods per semester	Credits	Continuous internal Evaluation(CIE)			Semester end examination (SEE)				
			L	T	P			Mid Sem1	Mid Sem 2	Internal Evaluation	Max marks Min marks	Total Marks	Min marks for passing including CIE		
1	HU-101	Basic English	4	1	0	75	3	20	20	20	40	14	100	35	
2	SC-102	Basic Engineering Mathematics	4	1	0	75	3	20	20	20	40	14	100	35	
3	SC-103	Basic Physics	4	1	0	75	3	20	20	20	40	14	100	35	
4	SC-104	General Engineering Chemistry	4	1	0	75	3	20	20	20	40	14	100	35	
5	CH-105	Materials Technology	4	1	0	75	3	20	20	20	40	14	100	35	
6	ME-106	Basic Engineering Drawing	1	0	2	45	1.5	20	20	20	40	20	100	50	
7	ME-107	Basic Auto Cad Lab	1	0	2	45	1.5	20	20	20	40	20	100	50	
8	ME-108	Basic Workshop Lab	1	0	2	45	1.5	20	20	20	40	20	100	50	
9	SC-109	Basic Science Lab	1	0	2	45	1.5	20	20	20	40	20	100	50	
10	CS-110	Basic Computer Science Lab	1	0	2	45	1.5	20	20	20	40	20	100	50	
11	CH-111	Skill Upgradation	0	0	8	120	2.5	0	0	Rubrics		--	-		
Activities: student performance is to be assessed through Rubrics															

HU-101 - Basic English

Course Title	Basic English	Course Code	HU-101
Semester	I	Course Group	Foundation
Teaching Scheme in Minutes (L:T)	4:1:0	Credits	3
Methodology	Communicative Language Teaching + Assignments	Total Contact Hours	75
CIE	60 Marks	SEE	40 Marks

Prerequisites: Basic knowledge of English Language

COURSE CONTENTS

MODULE 1: VOCABULARY

Duration: 12 Periods – (L 8 P 4)

1. How to Use a Dictionary
 - a) How to locate a word
 - b) Different kinds of dictionaries
 - c) Uses of dictionaries and digital dictionaries
2. Building Vocabulary
 - a) Words from other languages – Greek, Latin, French, Sanskrit, Hindi, and Telugu.
 - b) Words from names of people (Eponyms) with focus on terms used in science and technology.
 - c) Word Forms – Focus on words from Science and Technology.
3. Words Often Confused
 - a) Homonyms, Homophones.
 - b) Heteronyms, Heterophones
 - c) Capitonyms

MODULE 2: READING

Duration: 12 Periods – (L 8 P 4)

1. Purpose of Reading
2. Types of Reading
3. Types of Paragraphs and Questions (F I V E)

MODULE 3: SPEAKING

Duration: 12 Periods – (L 8 P 4)

1. Need for English
2. Classroom English

3. Expressing Feelings
4. Expressing Likes & Dislikes
5. Making Requests
6. How to Introduce Oneself
7. Expressing obligations.

MODULE 4: GRAMMAR I

Duration: 12 Periods – (L 8 P 4)

1. Basic Sentence Patterns
2. Tenses
3. Voice

MODULE 5: GRAMMAR II

Duration: 15 Periods – (L 10 P 5)

1. Adjectives
2. Prepositions
3. Asking Questions

MODULE 6: WRITING

Duration: 12 Periods – (L 8 P 4)

1. Paragraph Writing – I
2. Paragraph Writing – II
3. Letter Writing – I
4. Letter Writing – II

COURSE OUTCOMES

No.	At the end of the course, the students will have the ability to:
101.1	Use a dictionary and acquire vocabulary for social interaction.
101.2	Comprehend, identify main ideas, make inferences, visualize, and answer questions. Analyze and evaluate the written material.
101.3	Speak and write grammatically correct sentences, communicate effectively, express their likes, dislikes, feelings, make requests, express obligations and introduce themselves.
101.4	Use verbs in the different tenses according to the situations. Use Voice to express an action clearly
101.5	Describe people and objects, ask questions, use prepositions and write grammatically correct sentences.
101.6	Convey ideas in the form of paragraphs and letters

CO-PO Matrix

CO	PO 1	PO 2	PO 3	PO 4	PO 5	PO 6	PO 7	Mapping POs
101.1	-	-	-	-	3		3	5,7
101.2	-	-	-	-	3	2	3	5,6,7
101.3	-	-	-	-	3	3	3	5,6,7
101.4	-	-	-	-	2	2	3	5,6,7
101.5	-	-	-	-	2	2	3	5,6,7
101.6		-	--	--	2		3	5,7

Test	Units	Marks	Pattern
Mid Sem- I	1. Vocabulary 2. Reading	20	Part A: 4 short answer questions Part B: 2 short essay questions with internal choice Part C: 2 essay questions with internal choice
Mid Sem - II	1. Speaking 2. Grammar-1	20	Part A: 4 short answer questions Part B: 2 short essay questions with internal choice Part C: 2 essay questions with internal choice
Slip Test 1	1. Vocabulary 2. Reading	5	2 questions out of 3 questions
Slip Test 2	1. Speaking 2. Grammar-1	5	2 questions out of 3 questions
Assignment	One assignment per one semester	5	Different assignments of higher order questions that develop problem solving skills and critical thinking should be given
Seminars	One seminar per one semester	5	Oral presentations using audio–visual equipment, charts, etc.
	Total	60	

MID SEM - I EXAM					
S. No.	Unit Name	R	U	A	Remarks
1	Unit - I	1, 2	5 (a) 5 (b)	7 (a) 7 (b)	
2	Unit - II	3, 4	6 (a) 6 (b)	8 (a) 8 (b)	
Total Questions		4	4	4	
MID SEM - II EXAM					
S. No.	Unit Name	R	U	A	Remarks
1	Unit - I	1, 2	5 (a) 5 (b)	7 (a) 7 (b)	
2	Unit - II	3, 4	6 (a) 6 (b)	8 (a) 8 (b)	
Total Questions		4	4	4	

SEMESTER END EXAM					
Sl. NO.	Unit No.	Question to be set for SEE			Remarks
		R	U	A	
1	I	4	1	9 (a)	13 (a)
2	II				
3	III		2	10 (a)	14 (a)
4	IV				
5	V	3	5, 6	9 (b)	13 (b)
				11 (a)	15 (a)
				11 (b)	15 (b)
6	VI		7, 8	10 (b)	14 (b)
				12 (a)	16 (a)
				12 (b)	16 (b)
Total Questions		8	8	8	

Legend:

Remembering: one mark

Understanding: three marks

Application: five marks

Suggested Student Activities:

- Practice conversation / dialogue / speech and answer the questions.
- Group discussions.
- Seminars.
- Review a movie.
- Review a book.
- Narrating a story.
- Chain stories.
- JAM.
- Speak about incidents /events /memories /dreams /role model.
- Interviews of famous personalities.
- Reading for main ideas and specific details.
- Summarizing.
- Picture description.
- Writing a recipe.
- Describing a process.
- Giving directions using maps.
- Surveys.
- Filling forms.
- e-mail etiquette.
- Preparing reports on field visits, experiments, projects.
- General English for competitive exams – Practice the previous year’s question papers of SSC, RRB, TS TRANSCO, TSGENCO, etc.

REFERENCES:

1. Practical English Grammar by A.J Thomson and A.V. Martinet
2. A Course in Phonetics and Spoken English by J. Sethi and P.V Dhamija
3. Word Power Made Easy by Norman Lewis.
4. Keep Talking by Friederike Klippel.
5. More Grammar Games by Mario Rinvoluceri and Paul Davis.
6. Essential English Grammar by Raymond Murphy.
7. Spoken English-A Self Learning Guide to Conversation Practice by V Sasi Kumar.

E-learning resources:

1. www.duolingo.com
2. www.bbc.co.uk
3. www.babbel.com
4. www.merriam-webster.com
5. www.ello.org
6. www.lang-8.com

7. youtube.com
8. Hello English (app)
9. mooc.org
10. <https://onlinecourses.nptel.ac.in>
11. <https://www.indeed.com/career-advice/>
12. Dictionary.com
13. Online Dictionaries
14. <https://englishsentences.com>
15. <https://englishcub.com/vocabulary/dictionary-thesaurus.htm>
16. TEDx talks.
17. Toastmasters International on YouTube.

BOARD DIPLOMA EXAMINATION (C-21)
MID SEMESTER EXAMINATION – I
HU-101-BASIC ENGLISH

Time: 1 Hour

Total Marks: 20

PART - A

1 X 4 = 4

Instructions: Answer all the questions. Each question carries one mark.

1. Choose the correct guide words for the following words.

1. Pool:

- | | |
|------------------|-------------------|
| a. Play, Portico | b. Poem, Poet |
| c. Prosper, Pull | d. Porpoise, Pout |

2. Monkey:

- | | |
|----------------|----------------|
| a. Money, Monk | b. Mole, Mount |
| c. Moon, Most | d. More, move |

2. _____ is the Unit of Electric Current in SI Units named after Andre Marie Ampere.

3. Read the following passage and answer the question.

There once was a Bald Man who sat down after work on a hot summer's day. A Fly came up and kept buzzing about his bald pate, stinging him from time to time. The Man aimed a blow at his little enemy, but his palm came on his head instead; and again the Fly tormented him. But this time the Man was wiser, and said: "You will only injure yourself if you take notice of despicable enemies."

i) How can you say that the man has become wiser?

4. Read the following passage and answer the question.

An Eagle was soaring through the air when suddenly it heard the whizz of an Arrow, and felt itself wounded to death. Slowly it fluttered down to the earth, with its life- blood pouring out of it. Looking down upon the Arrow with which it had been pierced, it found that the shaft of the Arrow had been feathered with one of its own plumes. "Alas!" it cried, as it died. "We often give our enemies the means for our own destruction."

i) What did the eagle discover before its death?

PART - B

3 X 2 = 6

Instructions: Answer the following questions. Each question carries three marks

5. a) Read the following and use correct words in the blanks.

I went to _____ (meat/ meet) the _____ (Principle / Principal) but he was on _____ (live/ leave) for a _____ (weak / week). I had to _____ (weight / wait) in the room before I was _____ (allowed / aloud) to go out.

(OR)

b) Use the following set of words in sentences of your own to express the difference in the meaning.

- i) break - brake ii) stationery - stationary iii) waste - waist

6. a) Read the passage and answer the questions.

When I woke up it was broad daylight and the weather had cleared. The storm abated. The Ship was lifted off at night from the sand where she lay by the tie and was driven up almost as far as the rock where I have been bruised by the dashing. As the ship was upright and within a mile, I wish to board it to save necessary things for my use.

- (i) How was the weather in the morning?
(ii) What had happened to the ship at night?
(iii) Why did he wish to board the ship?

(OR)

b) Read the passage and answer the questions.

O. Henry's original name was William Sidney Porter, he was born on 11th September, in 1862, Greensboro, North Carolina, U.S. He died on 5th June, 1910, New York. He was an American short story writer whose tales romanticized the commonplace - in particular the life of ordinary people in New York City. His stories expressed the effect of coincidence on character through humour, grim or ironic, and often had surprise endings, a device that became identified with his name and cost him critical favour when its vogue had passed.

- (i) Who was William Sidney Porter?
(ii) What did his stories deal with?
(iii) What was the name he took up to write stories?

PART-C

5 X 2 = 10

Instructions: Answer the following questions. Each question carries five marks

7. a) Write the basic uses of a dictionary.

(OR)

b) How will you look up the word, "Travel", in the dictionary.

8. a) Read the passage and answer the questions.

An owl is a bird. There are two basic types of owls: typical owls and bam owls. Owls live in almost every country of the world. Owls are mostly nocturnal, meaning they are awake at night. Owls are predators – they hunt the food that they eat. Owls hunt for mince and other small mammals, insects and even fish. Owls are well adapted for hunting. Their soft, fluffy feathers make their flight nearly silent. They have very good hearing which helps them to hunt well in the darkness. The sharp hooked beaks and claws of the owl makes it very easy to tear apart their prey quickly, although owls also eat some prey whole.

Owl's eyes are unusual. Like most predators, both the eyes of the owl face front. The owl cannot move its eyes. Owls are far – sighted, which means they can see very well far away.... But they can't see dose very well at all. Fortunately, their distant vision is what they use for hunting and they see far away even in low light. Owls have facial disks around their eyes, tufts of feathers in a circle around each eye. These facial disks are thought to help the Owl's hearing. Owls can turn their heads 180 degrees is all the owl needs to see what's going on all around it. Perhaps because of the Owl's mysterious appearance, especially its round eyes and flexible neck, there are a lot of myths and superstitions about Owls. Many cultures believe that Owls are unusually wise. Because owls are nocturnal, some cultures associate owls with bad omens. The screech of the bam owl is considered by many to sound early human, like a person screaming. However, owls probably do not interact with fates of human at all. In fact, some owl species may become extinct because of humans.

- (i) How can you say that an owl is a predator? List a few special features present in predators.
- (ii) What helps owls in hunting?
- (iii) Why are myths and superstitions associated with an owl?
- (iv) Pick out the words from the passage which means:
 - a) A sign of something that will happen in the future.
 - b) In a strange frightening mysterious way.
- (v) What will you do if you see an owl with owlets in your college premises?

(OR)

b) Read the passage and answer the questions.

Marie Curie was born in Poland in 1867. She was the youngest of five children. Her father was a professor. Marie won a gold medal when she graduated from high school. She and her sister did private tutoring to earn money. At Sorbonne University she studied Mathematics and Physics. She earned a master's degree in Physics and with the help of a scholarship earned a master's in Mathematics. Later she received a doctorate in Physics. She met Pierre Curie and married him in 1895. Together they discovered two new radioactive elements. They named them Polonium and Radium. They received the Nobel Prize in the year 1903 for the discovery of Radioactivity along with Hennery Becquerel. In 1911 she received another Nobel Prize for the discovery of Polonium and Radium. In 1923 the French government gave her a pension of forty thousand Francs a year in recognition of her lifetime work in France. Many people have benefited from the discoveries made by Pierre and Marie Curie.

- (i) When and where was Marie Curie born?
- (ii) Why were they awarded the Nobel Prize?
- (iii) Write the antonyms for the following words:
 - a) Benefit
 - b) Youngest
- (iv) Why did the French government give her a pension?
- (v) How can you say many people have benefitted from discoveries made by Pierre and Marie Curie?

BOARD DIPLOMA EXAMINATION (C-21)
MID SEMESTER EXAMINATION – I
HU-101- BASIC ENGLISH

Time: 1 Hour

Total Marks: 20

PART - A

1 X 4 = 4

Instructions: Answer all the questions. Each question carries one mark.

1. Write a sentence to express the trait you like in your friend.
2. Rewrite the sentence using a word of obligation.
 - a) The teacher advised the students to work hard in order to get good marks.
3. Read the following sentence and write the sentence pattern.
 - a) I teach students.
 - b) Farmers are hard working.
4. Fill in the blank with the appropriate form of the verb.
 - a) He _____ (live) in that house since 2015.

PART - B

3 X 2 = 6

Instructions: Answer the following questions. Each question carries three marks.

5.
 - a) Write one expression used by the teacher.
 - (i) When the Class is noisy.
 - (ii) When a student is distracted.
 - (iii) When a student is permitted to leave early.
- OR**
- b) Write the feelings you express in the following situations.
 - (i) The train you have been waiting for hours has been cancelled.
 - (ii) Your mother says she is proud of you.
 - (iii) You forgot that a holiday was declared and went to college.
6.
 - a) Change the voice of the following sentences.
 - (i) He eats only vegetarian food.
 - (ii) Ethical hacking has been learnt by Gaurav.
 - (iii) Submit your application.

OR

- b) Fill in the blanks with simple past and past continuous forms of the verbs given in the brackets.

When the children ____i____ (Play) in the park, they ____ii____ (hear) the whimper of a small puppy. The friends ____iii____ (search) under the bushes and

____iv____ (find) a white puppy. When they ____v____ (try) to pacify it a big dog suddenly ____vi____ (appear).

PART-C

5 X 2 = 10

Instructions: Answer the following questions. Each question carries five marks.

7.

a) Write three difficulties faced by students while learning English. Give suggestion to overcome these difficulties.

OR

b) Write your introduction in a formal situation (You are Anish studying in class XII)

8.

a) Write a sentence using each of the given sentence patterns.

- a) S V b) S V O c) S V S C d) S V O OC
e) S VIODO

OR

b) Write your routine using ten verbs.

BOARD DIPLOMA EXAMINATION (C-21)
END SEMESTER EXAMINATION
HU-101- BASIC ENGLISH

Time: 2 Hours

Total Marks: 40

PART – A

8 X 1 = 8

Instructions: *1. Answer all the questions.*

2. Each question carries one mark.

1. Read the sentence and capitalize the words which represent the name of a country, month:
 - a. He bought a jersey in jersey.
 - b. They may come in may.

2. Rewrite the following sentence in the form of a request: to a friend, to your teacher.
Lend me your pen.

3. Frame “Yes” or “No” question for the following statement.
I have understood the problem.

4. Write the feeling you undergo in the following situation.
You see a small child working in a hotel at mid night while returning from a party.

5. Fill in the blanks with suitable prepositions.
Sreeni was angry _____ her mother _____ not permitting her to go to a late-night party.

6. Write a sentence about your teacher using two adjectives.

7. Write the salutation written to your friend while writing a letter.

8. Read the given paragraph and write the topic sentence.

The white Rhino is the largest mammal weighing around 300 Kgs. It has become endangered as humans hunt it for its horns. It has a wide mouth used for grazing and is the most social of all rhino species. White rhinoceroses are found in grassland and savannah habitat. [Herbivore grazers](#) that eat grass, preferring the shortest grains, the white rhinoceros is one of the largest pure grazers. It drinks twice a day if water is available, but if conditions are dry it can live four or five days without water. It spends about half of the day eating, one third resting, and the rest of the day doing various other things.

PART- B

4 X 3 = 12

Instructions: *1. Answer the following questions.*

2. Each question carries three marks.

9.
 - a) Read the following passage and answer the questions.

During the summer holidays, I lost my phone. And for the week that I was phoneless, it felt like a disaster. I love my phone. It gives me quick access to information and allows me to constantly be looped in with my friends, to know exactly what is going on in their lives. So, when I didn't have my phone for a week, I felt a slightly sense of FOMO, or if you are not up to speed with the lingo, fear of missing out. By the end of the week, I would have got used to not having a phone and I would have enjoyed the break from social media. But there was still a lingering sense of sadness at the back of my mind that there would be conversations I had missed, messages that there would be conversations I had missed, messages that had been sent, funny videos shared and night time chats that I would probably never get to see.

- i. What felt like a disaster to the writer?
- ii. Why does the writer love his phone?
- iii. How did the writer feel without the phone?

OR

- b) Read the following passage and frame two "Wh" questions and one "Yes No" questions:

Dr Seuss was born on March second 1904. He was an American cartoonist and writer. His real name was Theodor Seuss Geisel. He was born in Springfield, Massachusetts. Dr Seuss liked draw and write even as child. The first book that Dr Seuss wrote was titled "And to think that I saw it on Mulberry Street". He wrote it while on a ocean voyage, returning from a trip to Europe. The rhythm of the ship's engine gave him the feeling for the poetry rhythm in the story. Dr Seuss was not a real doctor. He added the "Dr" to his name to honour his dad, who wanted Theodor to become a doctor. Even though he never became a real doctor, he did write books that helped millions of kids to read. Dr Seuss had also used other names, pen names to write books. These names include Theophrastus Seuss, Theo Le Sieg which is his real name spelled backwards, and Rosetta stone. Dr Seuss wrote more than sixty children's books including some which have been made into movies such as "The Lorax", "The Cat in the Hat", "Horton Hears a Who", and "How the Grinch Stole Christmas". He wrote lots of books for children, even though he and his wife never had children of their own. He died at age 87 in San Diego California, USA.

10.

- a) Write as directed.
 - a) Write a sentence expressing what you like about the rainy season.
 - b) Rewrite the sentence using a word of obligation:
The Doctor told the patient to reduce the intake of salt, if he wants the healthy life.
- c) Write two hobbies you would express while giving your introduction.

OR

- b) Write a paragraph in 100 words about a festival you like.
- 11.
- a) Fill in the blanks with the proper order of adjectives given in brackets
- a) He ate _____ (green/ English / round / some) apples.
- b) She has _____ (lot of / old / interesting) books.
- c) My grandmother had always been _____ (slightly bend / fat / short).

OR

- b) Fill in the blank with adjectives or prepositions.
- Tiger is a _____ animal that lives _____ forests. It is _____ animal as it feeds _____ other animals. Tigers are very _____. The body _____ tigers is red or orange with black stripes.
- 12.
- a) Write a letter to your friend asking him to write about his college.

OR

- b) Write a paragraph on the importance of physical exercise.

PART-C

4 X 5 = 20

*Instructions: 1. Answer the following questions.
2. Each question carries five marks.*

- 13.
- a) Write about five different kinds of dictionaries.

OR

- b) Read the following passage and write three “Wh” questions and two “yes No” questions.

One of the results of Technology and population growth is increase of pollution throughout the world. According to United Nation’s report the future of all life on earth will be endangered. If man does not control contamination of the environment, It is time, we learn the full extent of the dangers that face mankind.

For instance, here in Egypt, look at River Nile. It is strange to see how everything is thrown into it as if it were litter basket. Instead of keeping it clean and pure, we pollute it. We our-selves, not our enemies, dirty it with our own hands. Some farmers wash themselves, their clothes, their animals, their pots and pans in its water. They even throw away their dead animals, and birds into it. Some people living in cities and towns throw their old tyres and broken bottles and rusty tins into it. Factories throw their waste chemicals and garbage. In this way the Nile water gets poisoned, kills fish, poisons land, weakens crops and destroys health.

So, it would be foolish to shut our eyes to the dangers of the pollution that man causes to the very thing on which his life depends. Please keep Nile clean.

- 14.
- a) Write five problems faced by students while learning English. Write your suggestions to overcome these problems.

OR

- b) Write a paragraph about Covid-19 pandemic in 150 words.
15. a) Describe your favourite place using ten adjectives.

OR

- b) Fill in the blanks with suitable prepositions.
He lives _____ (in / on) a beautiful cottage _____ (beside / besides) the river. There is a pathway _____ (between / among) the two flower beds leading _____ (to / from) the cottage. He has been living there _____ (since / for) his childhood.
16. a) Write a letter to your friend advising him to work hard to get good marks.

(OR)

- b) Write a letter to the editor of The Times of India about the problems faced by the students during the recent monsoon.

SC-102-BASIC ENGINEERING MATHEMATICS

Course Title	Basic Engineering Mathematics	Course Code	SC-102
SEMESTER	I	Course Group	Foundation
Teaching Scheme in periods (L : T : P)	4:1: 0	Credits	3 Credits
Methodology	Lecture + Tutorial	Total Contact Periods	75
CIE	60 Marks	SEE	40 Marks

Pre requisites:

This course requires the basic knowledge of Algebra, Trigonometry in Mathematics at Secondary school level

Course Outcomes: COs

At the end of the course, the student will have the ability to:

CO 1	Solve simple problems using concepts of Logarithms& Partial Fractions
CO 2	Determine the inverse of a square matrix using matrix algebra
CO 3	Calculate trigonometric ratios of allied and compound angles and Solve simple problems using concepts of multiple and sub multiple angles
CO 4	Understand the concepts of properties of triangles and determine various forms of complex numbers
CO 5	Transform sum or difference of trigonometric ratios into product and vice versa and also solve some problems in inverse trigonometric functions
CO 6	. Solve simultaneous Linear Equations using the concepts of Matrices and Determinants and solve some problems in solutions of triangles

Course Content:

Algebra

Unit-I

Duration: 08Periods (L: 06– T: 02)

1. Logarithms:

Definition of logarithm and its properties, natural and common logarithms; the meaning of e and exponential function, logarithm as a function and its graphical representation – Solve some simple problems.

2. Partial Fractions:

Definition of Rational, proper and improper fractions of polynomials. Resolving rational fractions in to their partial fractions covering the types mentioned below:

$$\begin{array}{ll}
 i) \quad \frac{f(x)}{(x+a)(x+b)(x+c)} & ii) \quad \frac{f(x)}{(x+a)^2(x+b)(x+c)} \\
 iii) \quad \frac{f(x)}{(x^2+a)(x+b)} & iv) \quad \frac{f(x)}{(x+a)(x^2+b)^2}
 \end{array}$$

UNIT-II

Duration: 16 Periods (L: 12 – T:

04)

- 1. Matrices and Determinants:** Definition of matrix, types of matrices-examples, algebra of matrices-equality of two matrices, sum, difference, scalar multiplication and product of matrices. Transpose of a Matrix- Symmetric, Skew symmetric matrices- Minor, cofactor of an element-Determinant of a square matrix up to 3rd order -Laplace's expansion, properties of determinants. Singular and non-singular matrices- Adjoint and multiplicative inverse of a square matrix –related problems.

Trigonometry:

Unit-III

Duration: 14 Periods (L: 12 – T:

02)

- 1. Compound angles:** Formulae of Sin (A±B), Cos (A±B), Tan (A±B), Cot(A±B), and related identities with problems - Derive the values of $\sin 15^\circ$, $\cos 15^\circ$, $\sin 75^\circ$, $\cos 75^\circ$, $\tan 15^\circ$, $\tan 75^\circ$ etc.-Derive identities like $\sin(A+B) \sin(A-B) = \sin^2 A - \sin^2 B$ etc.,
- 2. Multiple and sub multiple angles:** Trigonometric ratios of multiple angles 2A, 3A and submultiples angle A/2 with problems - Derive useful allied formulas like

$$\sin^2 A = \left(\frac{1 - \cos 2A}{2} \right) \text{ etc., - Solve simple problems using the above formulae}$$

Unit – IV

Duration: 10 Periods (L: 08– T:

2.0)

- 1. Properties of triangles:** Statements of Sine rule, Cosine rule, Tangent rule and Projection rule and solve some simple problems using above rules

2. **Hyperbolic functions:** Definitions of hyperbolic functions – Sin h(x), Cos h(x) , Tan h(x) etc., - identities of hyperbolic functions, inverse hyperbolic functions and expression of inverse hyperbolic functions in terms of logarithms.
3. **Complex Numbers:** Definition of a complex number, Modulus and conjugate of a complex number, Arithmetic operations on complex numbers, Modulus- Amplitude (polar) form, Exponential (Euler) form of a complex number.

Algebra & Trigonometry

Unit – V

Duration: 13Periods (L: 11 – T:

2.0)

1. **Transformations:** Transformation of products into sums or differences and vice versa - Simple problems - Solve problems by applying these formulae to sum or difference or product
2. **Inverse trigonometric functions:** Define inverses of six trigonometric functions along with their domains and ranges - Derive relations between inverse trigonometric functions so that given $A = \sin^{-1}x$, express angle A in terms of other inverse trigonometric functions - with examples - State various properties of inverse trigonometric functions and identities like $\sin^{-1}x + \cos^{-1}x = \frac{\pi}{2}$ etc - solve simple problems. like $\tan^{-1}x + \tan^{-1}y = \tan^{-1}\left(\frac{x+y}{1-xy}\right)$ where $x \geq 0$, $y \geq 0$, $xy < 1$

Unit – VI

Duration: 14 Periods (L:11– T:03)

1. **Solution of Simultaneous equations using Matrices & Determinants.:** System of linear equations in 3 Variables-Solutions by Cramer's rule, Matrix inversion method – Examples- Elementary row operations on Matrices -Gauss-Jordan method to solve a system of equations in 3 unknown variables
2. **Solutions of triangles:** Solve a triangle when (i) Three sides (SSS) (ii) Two sides and an Included angle (SAS) (iii) One side and two angles are given (SAA) - Simple problems.

References

1. Text Book of Matrices – by Shanti Narayan
2. Plane Trigonometry - by S. L. Loney
3. NCERT Mathematics Text Books Of Class XI, XII.
4. Intermediate Mathematics Text Books (Telugu Academy)

Suggested E-Learning references

1. www.freebookcentre.net/mathematics/introductory-mathematics-books.html
2. E-books:www.mathebook.net

Suggested Learning Outcomes:

At the end of the course, the student will have the ability to:

Algebra

UNIT – I

1.0 Use Logarithms in engineering calculations

- 1.1 Solve some simple Logarithm problems. Using logarithm properties
- 1.2 Distinguish natural logarithms and common logarithms.
- 1.3 Explain the meaning of e and exponential function.
- 1.4 Understand logarithm as a function and its graphical representation.

Resolve Rational Fraction into sum of Partial Fractions in engineering problems

- 1.5 Define the following fractions of polynomials:
 - i) Rational
 - ii) Proper and
 - iii) Improper
- 1.6 Resolving rational fractions of the type mentioned below into partial fractions

$$\begin{array}{ll} i) \quad \frac{f(x)}{(x+a)(x+b)(x+c)} & ii) \quad \frac{f(x)}{(x+a)^2(x+b)(x+c)} \\ iii) \quad \frac{f(x)}{(x^2+a)(x+b)} & iv) \quad \frac{f(x)}{(x+a)(x^2+b)^2} \end{array}$$

UNIT – II

2.0 Use Matrices for solving engineering problems:

- 2.1 Know the matrix and types of a matrix.
- 2.2 Compute sum, difference, scalar multiplication and product of matrices.
- 2.3 Know the properties of these operations such as associative, distributive, commutative properties with examples and counter examples.
- 2.4 Define the transpose of a matrix and write its properties.
- 2.5 Define symmetric and skew-symmetric matrices.

- 2.6 Resolve a square matrix into a sum of symmetric and skew-symmetric matrices with examples in all cases.
- 2.7 Define minor, co-factor of an element of a 3x3 square matrix with examples.
- 2.8 Expand the determinant of a 3 x 3 matrix using Laplace expansion formula.
- 2.9 Distinguish singular and non-singular matrices.
- 2.10 Apply the properties of determinants to solve problems.
- 2.11 Compute Adjoint and multiplicative inverse of a square matrix.

Trigonometry:

UNIT – III

3.0 Solve simple problems on Compound Angles

- 3.1 Understand the compound angles and able to write the formulae of $\sin(A \pm B)$, $\cos(A \pm B)$, $\tan(A \pm B)$ and $\cot(A \pm B)$
- 3.2 Able to derive the values of $\sin 15^\circ$, $\cos 15^\circ$, $\tan 15^\circ$ and $\sin 75^\circ$, $\cos 75^\circ$, $\tan 75^\circ$ etc.
- 3.3 Derive identities like $\sin(A+B)$, $\sin(A-B) = \sin^2 A - \sin^2 B$ etc.,
- 3.4 Solve simple problems on compound angles.

Solve problems using the formulae for Multiple and Sub-Multiple Angles

- 3.5 Derive the formulae of multiple angles $2A$, $3A$ etc and sub multiple angles $A/2$ in terms of angle A of trigonometric functions.
- 3.6 Derive useful allied formulas like $\sin^2 A = \left(\frac{1 - \cos 2A}{2}\right)$ etc.,
- 3.7 Solve simple problems using the above formulae

UNIT – IV

4.0 Appreciate Properties of triangles:

- 4.1 Understand the sine, cosine, tangent and projection rules. Solve some simple problems

Represent the Hyperbolic Functions in terms of logarithm functions

- 4.2 Understand $\sinh x$, $\cosh x$ and $\tanh x$ and list the hyperbolic identities.
- 4.3 Represent inverse hyperbolic functions in terms of logarithms.

Represent Complex numbers in various forms:

- 4.4 Understand the complex number, its modulus, and conjugate and list their properties.

4.5 Represent the complex number in various forms like modulus-amplitude (polar) form, Exponential (Euler) form – illustrate with examples.

UNIT – V

5.0 Apply Transformations for solving the problems in Trigonometry:

- 5.1 Derive the formulae on transforming sum or difference of two trigonometric ratios in to a product and vice versa- examples on these formulae.
- 5.2 Solve problems by applying these formulae to sum or difference or product of three or more terms.

Use Inverse Trigonometric Functions for solving engineering problems:

- 5.3 Know the concept of the inverse of a trigonometric function by selecting an appropriate domain and range.
- 5.4 Derive relations between inverse trigonometric functions so that given $A = \sin^{-1}x$, express angle A in terms of other inverse trigonometric functions - with examples.
- 5.5 State various properties of inverse trigonometric functions and identities like $\sin^{-1}x + \cos^{-1}x = \frac{\pi}{2}$ etc.
- 5.6 Solve some problems like $\tan^{-1}x + \tan^{-1}y = \tan^{-1}\left(\frac{x+y}{1-xy}\right)$ where $x \geq 0, y \geq 0$
And $xy \leq 1$

UNIT – VI

6.0 Apply Matrices and Determinants in solving system of Linear Equations:

- 6.1 Solve system of linear equations with 2 and 3 unknown variables using Cramer's rule.
- 6.2 Solve system of linear equations with 2 and 3 unknown variables by matrix inversion method
- 6.3 State elementary row operations.
- 6.4 Solve a system of linear equations in 3 unknown variables by Gauss- Jordan method

Apply Properties of Triangles to solve a triangle.

- 6.5 Solve a triangle when
 - i. Three sides (SSS)
 - ii. Two sides and an included angle (SAS),
 - iii. One side and two angles are given (SAA).

Suggested Student Activities

1. Student visits Library to refer Standard Books on Mathematics and collect related material.
2. Quiz
3. Group discussion
4. Surprise tests
5. Seminars
6. Home Assignments.
7. Mathematics- for preparing competitive exams and solve some arithmetical ability exam Questions

CO / PO - MAPPING

CO	PO1	PO2	PO3	PO4	PO5	PO6	PO7	Mapped POs
CO1	3	1					3	1,2,7
CO2	3	2					3	1,2,7
CO3	3	2					3	1,2,7
CO4	3	2					3	1,2,7
CO5	3	2					3	1,2,7
CO6	3	2					3	1,2,7

MID SEM-I EXAM

S.No	Unit Name	R	U	A	Remarks
1	Unit-I	1, 2	5(a) 5(b)	7(a) 7(b)	
2	Unit-II	3, 4	6(a) 6(b)	8(a) 8(b)	
Total Questions		4	4	4	

MID SEM –II EXAM

S.No	Unit Name	R	U	A	Remarks
1	Unit-III	1, 2	5(a) 5(b)	7(a) 7(b)	
2	Unit-IV	3, 4	6(a) 6(b)	8(a) 8(b)	
Total Questions		4	4	4	

Semester End Examination

Sl No	Unit No.	Questions to be set for SEE			Remarks		
		R	U	A			
1	I	4	1	9(a)	13(a)		
2	II						
3	III		2	10(a)	14(a)		
4	IV						
5	V	4	3	5, 6	9(b) 11(a) 11(b)	13(b) 15(a) 15(b)	
6	VI			7,8	10(b)	14(b)	
					12(a) 12(b)	16(a) 16(b)	
Total Questions		8		8	8		

Legend:	Remembering (R)	1 Mark
	Understanding (U)	3 Marks
	Application (A)	5 Marks

BOARD DIPLOMA EXAMINATIONS (C21)
MID SEMESTER EXAMINATIONS - I
SC-102 - BASIC ENGINEERING MATHEMATICS

TIME: 1: 00 Hour

Max. Marks: 20

PART-A

Instructions: 1. Answer **ALL** questions 04 X 01 = 04

2 Each question carries **ONE** mark

1. Find the value of $\log_8 2$
2. Define Proper fraction and give an example.
3. If $A = \begin{bmatrix} 1 & 2 \\ -2 & 3 \end{bmatrix}$ and $B = \begin{bmatrix} 4 & -1 \\ 3 & 2 \end{bmatrix}$ Then Compute $3A + 5B$.
4. Find the value of $\begin{vmatrix} 1 & 2 \\ 3 & 4 \end{vmatrix}$.

PART-B

Instructions: 1. Answer All questions 02 X 03 = 06

2. Each question carries **THREE** marks

- 5.
- a) Resolve: $\frac{x}{(x-1)(x-2)}$ into partial fractions

OR

- b) Find the value of $\log_2 16 + 3\log_8 32$

6.

- a) If $\begin{pmatrix} 2 & 1 & 2 \\ 1 & 4 & 1 \\ 1 & 3 & 2 \end{pmatrix}$, then Compute $A^2 + 2A - 3I$, where **I** is a unit matrix of order 3

OR

- b) Find x if $\begin{vmatrix} 1 & 0 & 0 \\ 2 & 3 & 4 \\ 5 & -6 & x \end{vmatrix} = 48$

PART C

Instructions: 1. Answer All questions

02 X 05 = 10

2. Each question carries **FIVE** marks

7.

a) Resolve $\frac{9}{(x-1)(x+2)^2}$ into Partial fractions:

OR

b) Prove that $\log\left(\frac{75}{60}\right) - 2\log\left(\frac{5}{9}\right) + \log\left(\frac{32}{243}\right) = \log 2$

8.

a) If $A = \frac{1}{3} \begin{bmatrix} 1 & 2 & 2 \\ 2 & 1 & -2 \\ -2 & 2 & -1 \end{bmatrix}$, then show that $A^{-1} = A^T$

OR

b) Show that $\begin{vmatrix} b+c & a & a \\ b & c+a & b \\ c & c & a+b \end{vmatrix} = 4abc$.

@@@

BOARD DIPLOMA EXAMINATIONS (C21)
MID SEMESTER EXAMINATION
SC-102- BASIC ENGINEERING MATHEMATICS

TIME: 1: 00 Hour

Max. Marks: 20

PART-A

Instructions: 1. Answer **ALL** questions 04 X 01 = 04

2 Each question carries **ONE** mark

1. Write the formulae for Sin (A - B) and Cos (A - B)
2. If $\tan A = 2$, Find the value of $\cos 2A$.
3. Write the formula for Cosine rule.
4. Find the Modulus of $\frac{2}{3+2i}$

PART-B

Instructions: 1. Answer All questions 02 X 03 = 06

2. Each question carries **THREE** marks

5.

a) Show that $\frac{\cos 27^\circ + \sin 27^\circ}{\cos 27^\circ - \sin 27^\circ} = \tan 57^\circ$

OR

b) Prove that $\cos 20^\circ \cos 30^\circ \cos 40^\circ \cos 80^\circ = \frac{\sqrt{3}}{16}$.

6.

a) Write any 3 formulae from Hyperbolic functions.

OR

b) Find the modulus of $\frac{1}{2+4i}$

PART C

Instructions: 1. Answer All questions

02 X 05 = 10

2. Each question carries **FIVE** marks

7.

a) Prove that
$$\frac{(\tan A + \sec A - 1)\cos A}{\sin A + \cos A - 1} = \frac{1 + \sin A}{\cos A}$$

OR

b) Prove that
$$\cos^2 A + \cos^2 (60^\circ + A) + \cos^2 (60^\circ - A) = \frac{3}{2}$$

8.

a) Find the additive and multiplicative Inverse of $4 + 3i$

OR

b) Express the complex number $\frac{1+i}{1-i}$ in Exponential form

@@@

BOARD DIPLOMA EXAMINATION (C-21)
SEMESTER END EXAMINATION
SC-102- BASIC ENGINEERING MATHEMATICS

Time: 2 hours

[Total Marks: 40]

PART-A

Instructions: 1. Answer **ALL** questions 08 X 01 = 08

2 Each question carries **ONE** mark

1. Define proper fraction.
2. Write the formula for $\cos(A + B)$ and $\tan(A + B)$
3. Define solution of a triangle.
4. Find the value of $\log_4 16$.
5. Convert $\sin 6\theta + \sin 8\theta$ in to product
6. If $\sin^{-1} \frac{3}{5} = A$ then find $\cot A$.
7. List the elements of a triangle ABC.
8. What is the formula for the solution of triangle ABC when three sides are given

PART-B

Instructions: 1. Answer All questions 04 X 03 = 12

2. Each question carries **THREE** marks

9 (a) Resolve : $\frac{9}{(x-1)(x+2)^2}$ into Partial fractions:

9 (b) Prove that $\frac{\sin 8\theta + \sin 6\theta}{\cos 8\theta + \cos 6\theta} = \tan 7\theta$

10 (a) Express $\frac{9}{4+3i}$ in the form of $a + bi$.

Or

10(b) Solve the triangle ABC with $a=2$, $A=30^\circ$, $C=30^\circ$.

11(a) Prove that $\sin 50^\circ - \sin 70^\circ + \sin 10^\circ = 0$.

Or

11(b) Prove that $\tan^{-1} \frac{2}{7} + \tan^{-1} \frac{1}{5} = \tan^{-1} \frac{17}{33}$.

12(a) Solve $\begin{bmatrix} 3 & 2 \\ 2 & -3 \end{bmatrix} \begin{bmatrix} x \\ y \end{bmatrix} = \begin{bmatrix} 4 \\ 7 \end{bmatrix}$.

Or

12 (b) Find the angle C in any triangle ABC if $b = \sqrt{2}$, $c = \sqrt{3}$, $B = 45^\circ$.

PART C

Instructions: 1. Answer All questions

04 X 05 = 20

2. Each question carries **FIVE** marks

13(a) Find the Adjoint of the matrix $\begin{bmatrix} 1 & 3 & 4 \\ -1 & 2 & 1 \\ 0 & 3 & 3 \end{bmatrix}$

Or

13 (b) Prove that $\sin \theta + \sin(120^\circ + \theta) - \sin(120^\circ - \theta) = 0$

14 (a) Prove that $\cos 6^\circ \cdot \cos 42^\circ \cdot \cos 66^\circ \cdot \cos 78^\circ = \frac{1}{6}$

(b) Solve: $x + y + z = 6$, $x + 2y + 3z = 14$, $x + 4y + 9z = 3$ by using inverse Matrix method.

15(a) In any triangle ABC prove that $\sin 2A + \sin 2B + \sin 2C = 4 \sin A \sin B \sin C$

15(b) if $\tan^{-1} x + \tan^{-1} y + \tan^{-1} z = \frac{\pi}{2}$ then prove that $xy + yz + zx = 1$

16(a) Solve: $x + 2y - z = -3$, $3x + y + z = 4$, $x - y + 2z = 6$ by Cramer's Rule.

Or

16 (b) Solve the triangle ABC with $a = 1$ $b = 2$ $c = \sqrt{2}$.

@@@

SC-103 BASIC PHYSICS

Course Title	Basic Physics	Course Code	SC-103
Semester	Semester-I	Course Group	Foundation
Teaching Scheme in Pds(L:T:P)	4:1:0	Credits	3
Type of course	Lecture+Tutorial	Total Contact Periods	75
CIE	60 Marks	SEE	40 Marks

Pre requisites: High School Science and Mathematics

Course Objectives: After studying this course, the student will be able to understand and appreciate the role of Physics in different areas of engineering and technology.

Course outcomes: On successful completion of the course, the student will have the ability to attain below Course Outcomes (CO):

CO1	Identify physical quantities, select their units for use in engineering solutions, and make measurements with accuracy by minimizing different types of errors.
CO2	Apply laws of Vectors as tools to solve engineering problems
CO3	Explain friction on horizontal and inclined surfaces, analyze projectile and circular motions and apply the formulation to projectiles and central forces and solve engineering problems
CO4	Explain Hooke's law, properties of fluids viz surface tension, viscosity and significance of Reynolds's number and apply Bernoulli's principle to solve engineering problems
CO5	Apply conservation laws to various energy sources
CO6	Apply Heat and thermodynamic processes and formulate to understand engineering problems

CO	PO1	PO2	PO3	PO4	PO5	PO6	PO7
CO1	3	-	-	-	-	-	2
CO2	3	1	-	-	-	-	2
CO3	3	1	-	-	-	-	2
CO4	3	1	-	1	-	-	2
CO5	3		-	-	1	-	2
CO6	3	1	-	-	-	-	2
	3	1		1	1		2

SC-103 - BASIC PHYSICS

Course Contents

1. UNIT - 1 UNITS, DIMENSIONS AND MEASUREMENTS

Duration: 12 periods

Physical quantity – Fundamental and derived quantities, unit – definitions – system of units – Advantages of S.I. units

Dimensions and dimensional formula – definitions, units and dimensional formulae for physical quantities, Dimensionless quantities, Principle of homogeneity, Applications of dimensional analysis – Checking the correctness of physical equations – conversion of unit from one system to another system – problems on density, force and energy

Error in measurement – accuracy and precision of instruments, rules for representing significant figures-Numerical problems

2. UNIT – 2 VECTORS

Duration: 13 periods

Scalar and Vector quantities – definition and examples, representation of a vector, Classification of vectors - Proper vector, Equal vectors, Unit vector, Negative vector, null vector and Position vector, Resolution of a vector.

Lami's theorem, Parallelogram law of vectors – statement- expression for magnitude and direction of resultant vector –derivation- illustrations(working of sling and flying bird), Representation of a vector in unit vectors \mathbf{i} , \mathbf{j} and \mathbf{k} . – numerical problems.

Scalar product of vectors- application to work done by force and power – properties of scalar product. – Numerical problems.

Vector product of vectors– Right hand thumb rule and right hand screw rule - application to torque - properties of vector product - Application to area of parallelogram and triangle -numerical problems.

3. UNIT -3 MECHANICS

Duration: 13 periods

Concept of Friction - Normal reaction, Angle of friction, Motion of a body over a rough horizontal surface - expressions for Acceleration, Displacement, Time taken to

come to rest - derivations, inclined plane - Motion of a body over a smooth inclined plane and rough inclined plane—forces acting on the body -angle of repose, Application of friction – brake system in bicycle– numerical problems

Projectile motion – definition – examples, Horizontal projection - Oblique projection, Expression for path of a projectile in oblique projection –derivation, Maximum height, Time of ascent, Time of descent, Time of flight, Horizontal range and maximum horizontal range in oblique projection– derivations, numerical problems

Circular motion – definition of angular displacement, angular velocity, angular acceleration, frequency and time period, Relation between linear and angular velocity – derivation – related numerical problems, Central force – examples, Expressions for centripetal and centrifugal forces (no derivation), Applications of centripetal and centrifugal forces - Banking of roads and its expression, bending of cyclist and principle of centrifuge - related numerical problems.

4. UNIT – 4 PROPERTIES OF MATTER

Duration: 12 periods

Elasticity – Elastic body –definition - examples, Stress and Strain – definitions and expressions, types of stress and strain, elastic limit - Hooke’s law – statement – modulus of elasticity, significance of stress and strain curve -Young’s modulus – Derivation, numerical problems

Cohesive and Adhesive forces - Surface tension - Capillarity –angle of contact – definition- examples for capillarity- Formula for Surface tension based on capillarity (no derivation), effect of temperature and impurity on surface tension, applications and illustrations of surface tension, numerical problems.

Viscosity - Newton’s formula for viscous force – derivation - Coefficient of viscosity - Poiseuille’s equation (formula only), Effect of temperature on viscosity of liquids and gases, applications of viscosity, numerical problems.

Concept of fluid motion –streamline and turbulent flow, Reynold’s number, equation of continuity, Bernoulli’s theorem (only formula) and applications - related problems.

5. UNIT – 5 CONSERVATION LAWS AND ENERGY SOURCES

Duration: 12 periods

Work, Power and Energy – explanation, Potential Energy and Kinetic energy– examples – expressions for Potential energy and Kinetic energy– derivations, Work-Energy theorem – derivation, Law of conservation of energy – examples, Law of conservation of energy in the case of freely falling body – proof – Illustration of

conservation of energy in the case of simple pendulum, Nonrenewable and renewable energy sources – definition and applications (solar cooker, wind mill and biogas plant), Green House effect, Energy conservation (saving) methods - domestic and industrial, related problems

6. UNIT – 6 HEAT

Duration: 13 periods

Heat – thermal expansion of solids – Coefficients of expansions, different scales of temperature- Centigrade and Fahrenheit and their relationship, Bimetallic strip – applications in daily life - electric heater thermostat- circuit breaker-iron box, Boyle’s law – statement, concept of absolute zero - Absolute scale of temperature, Charles’ laws, Ideal gas equation – derivation - value of universal gas constant ‘R’, Gas equation in terms of density, Isothermal and Adiabatic processes - Differences between isothermal and adiabatic processes, Internal energy and External work done, Expression for work done – derivation, first law of thermodynamics –application of first law to isothermal and adiabatic processes, second law of thermodynamics, specific heats of a gas, related numerical problems.

LEARNING OUTCOMES:

Upon completion of the course the student shall be able to

UNITS, DIMENSIONS AND MEASUREMENTS

- 1.1 Define Physical quantity, fundamental quantity and derived physical quantity.
- 1.2 Classify system of units (FPS, CGS, MKS and SI) and outline advantages of S.I. units.
- 1.3 Write S.I. units of physical quantities.
- 1.4 Define Dimensions and dimensional formulae of physical quantities.
- 1.5 List dimensional formulae of physical quantities.
- 1.6 List dimensionless quantities.
- 1.7 Explain Principle of homogeneity of dimensions.
- 1.8 List the applications of dimensional formulae.
- 1.9 List the limitations of dimensional analysis.
- 1.10 Apply dimensional formulae to check the correctness of physical equations and to convert a unit from one system to another system (density, force and energy).
- 1.11 Define accuracy and precision of instruments, random and systematic errors.
- 1.12 List the rules for representing significant figures.
- 1.13 Solve simple numerical problems.

VECTORS

- 2.1 Define Scalar and Vector quantities with examples.

- 2.2 Represent a vector graphically and label vector characteristics.
- 2.3 Classify Vectors - Proper vector, Equal vector, Unit vector, Negative vector, Null vector and Position vector.
- 2.4 Resolve a Vector into two orthogonal components.
- 2.5 Explain Lami's theorem.
- 2.6 Explain Parallelogram law of vectors and develop expressions for magnitude and direction of resultant vector.
- 2.7 Illustrate parallelogram law of vectors (working of sling and flying bird).
- 2.8 Represent a vector in terms of unit vectors ($\hat{i}, \hat{j}, \hat{k}$).
- 2.9 Explain Scalar product of vectors.
- 2.10 Apply scalar product to work done by force and power.
- 2.11 List the properties of scalar product.
- 2.12 Explain vector product of vectors.
- 2.13 Explain right hand thumb rule and right hand screw rule.
- 2.14 Apply vector product to explain torque.
- 2.15 List the properties of vector product.
- 2.16 Extend vector product to area of parallelogram and area of triangle.
- 2.17 Solve related numerical problems.

MECHANICS

- 3.1 Explain concept of friction.
- 3.2 Explain Normal reaction and Angle of friction.
- 3.3 Derive expression for acceleration of a body on a rough horizontal surface.
- 3.4 Derive expressions for displacement and time taken to come to rest by a body over a rough horizontal surface.
- 3.5 Explain and label the forces acting on a body moving over smooth and rough inclined planes.
- 3.6 Define angle of repose.
- 3.7 Apply friction in brake system of moving vehicles such as bicycle.
- 3.8 Explain and classify Projectile motion with examples.
- 3.9 Derive expression for path of a projectile in oblique projection.
- 3.10 Develop formulae for Maximum height, Time of ascent, Time of descent, Time of flight, Horizontal range and maximum horizontal range of a projectile in oblique projection.
- 3.11 Explain circular motion and define angular displacement, angular velocity, angular acceleration, frequency and time period.
- 3.12 Develop a relation between linear velocity and angular velocity.
- 3.13 Explain Central force with examples and outline expressions for Centripetal and Centrifugal forces.
- 3.14 Apply centripetal and centrifugal forces to banking of roads, bending of cyclist and centrifuge.

3.15 Solve related numerical problems.

PROPERTIES OF MATTER

- 4.1 Define Elasticity and elastic bodies with examples.
- 4.2 Define Stress and Strain with their expressions.
- 4.3 Explain types of stress and strain.
- 4.4 Define Elastic limit.
- 4.5 Explain Hooke's law.
- 4.6 Outline the significance of stress and strain curve.
- 4.7 Develop a formula for Young's modulus of a wire having circular cross-sectional area.
- 4.8 Compare Cohesive and Adhesive forces.
- 4.9 Explain Surface tension and illustrate Surface tension with examples.
- 4.10 Define capillarity and angle of contact.
- 4.11 Outline the formula for Surface tension based on capillarity ($T = \frac{1}{2} h d \rho g$).
- 4.12 Effect of temperature and impurity on surface tension of a liquid.
- 4.13 Explain Viscosity.
- 4.14 Develop Newton's formula for viscous force and explain coefficient of viscosity.
- 4.15 Outline Poiseuille's equation for coefficient of viscosity.
- 4.16 Explain the effect of temperature on viscosity of liquids and gases.
- 4.17 Identify the importance of viscosity in blood flow through arteries, liquid soap, paint, lubricants and braking oil.
- 4.18 Explain Streamline flow and Turbulent flow.
- 4.19 Define Reynold's number and explain its significance.
- 4.20 Outline the Equation of Continuity and explain the terms with diagram.
- 4.21 Explain Bernoulli's theorem.
- 4.22 Apply Bernoulli's theorem to dynamic lift (aero foil lift, swing of a ball, blowing of roofs, atomizer, Bunsen burner).
- 4.23 Solve related numerical problems.

CONSERVATION LAWS AND ENERGY SOURCES

- 5.1 Explain concept of Work, Power and Energy.
- 5.2 Explain Potential energy and Kinetic energy with examples.
- 5.3 Develop expressions for Potential energy and Kinetic energy.
- 5.4 State Work-Energy theorem and prove the relation.
- 5.5 State law of conservation of energy with examples.
- 5.6 Prove law of conservation of energy in the case of a freely falling body.
- 5.7 Illustrate law of conservation of energy in the case of simple pendulum.
- 5.8 Explain Non-renewable and Renewable energy sources and list the examples.
- 5.9 Explain Solar cooker, Wind mill and Biogas plant with neat diagrams.
- 5.10 Explain Green House effect.
- 5.11 List domestic and industrial energy conservation methods.

5.12 Solve related numerical problems.

HEAT

- 6.1 Explain thermal expansion of solids and three coefficients of expansion of solids.
- 6.2 Outline Centigrade and Fahrenheit scales of temperature and relate them.
- 6.3 Explain principle of Bimetallic strip.
- 6.4 Apply principle of bimetallic strip to electric water heater thermostat, circuit breaker and iron box.
- 6.5 Explain Boyle's law in gases and its limitations.
- 6.6 Explain concept of Absolute Zero using the relations $P_t = P_0[1 + \frac{t}{273}]$ and $V_t = V_0[1 + \frac{t}{273}]$.
- 6.7 Explain Absolute scale of temperature.
- 6.8 Explain Charles' laws in gases in terms of absolute temperature.
- 6.9 Develop Ideal gas equation and calculate the value of Universal gas constant.
- 6.10 Translate gas equation in terms of density.
- 6.11 Explain Isothermal and Adiabatic processes and distinguish between them.
- 6.12 Explain the terms internal energy and external work done.
- 6.13 Derive the expression for work done by the gas [$W=P(V_2-V_1)$].
- 6.14 Explain first law of thermodynamics and list applications of it.
- 6.15 Apply first law of thermodynamics to isothermal and adiabatic processes.
- 6.16 Explain second law of thermodynamics and list applications of it.
- 6.17 Define specific heats and molar specific heats of a gas.
- 6.18 Solve related numerical problems.

References:

1. Principles of Physics by N. Subrahmanyam and Brijlal, S. Chand & Co, New Delhi, edition, 1982
2. Engineering. Physics by R.K. Gaur, S.L. Gupta, Dhanpatrai Publications, New Delhi.
3. ISC Physics, Book I&II, P. Vivekanandan, DK Banerjee, S Chand, New Delhi.
4. Intermediate Physics, Vol. I&II, Telugu Academy, TS, Hyderabad.
5. Fundamentals of Physics by Halliday and Resnick.

E-learning resources:

1. Hyper Physics website: <http://hyperphysics.phy-astr.gsu.edu/>

MID SEM-I EXAM

S.No	Unit Name	R	U	A	Remarks
1	Unit-I	1, 2	5(a) 5(b)	7(a) 7(b)	
2	Unit-II	3, 4	6(a) 6(b)	8(a) 8(b)	
Total Questions		4	4	4	
MID SEM –II EXAM					
S.No	Unit Name	R	U	A	Remarks
1	Unit-III	1, 2	5(a) 5(b)	7(a) 7(b)	
2	Unit-IV	3, 4	6(a) 6(b)	8(a) 8(b)	
Total Questions		4	4	4	

Semester End Examination

Sl No	Unit No.	Questions to be set for SEE			Remarks		
		R	U	A			
1	I	4	1	9(a)	13(a)		
2	II			10(a)	14(a)		
3	III		3	5, 6	9(b)	13(b)	
4	IV				11(a)	15(a)	
5	V			11(b)	15(b)		
				7,8	10(b)	14(b)	
6	VI	12(a)	16(a)				
Total Questions		8	8	8			

Legend:	Remembering (R)	1 Mark
	Understanding (U)	3 Marks
	Application (A)	5 Marks

BOARD DIPLOMA EXAMINATION (C-21)
MID SEM-I
FIRST SEMESTER EXAMINATION
SC-103 - BASIC PHYSICS

Time: 1 Hour

Total Marks: 20

PART-A

Instructions: 1. Answer **ALL** questions.
2. Each question carries **ONE** mark. 4X1 =4

1. Define fundamental physical quantity.
2. Write dimensional formula for work.
3. Define vector quantity.
4. Define unit vector.

PART-B

Instructions: 1. Answer **ALL** questions.
2. Each question carries **THREE** marks. 2X3 =6

5. (a). Outline three applications of dimensional analysis.
(OR)
(b). Outline any three rules for representing significant figures.
6. (a). Explain Lami's theorem.
(OR)
(b). Explain right hand screw rule of vector product.

PART-C

Instructions: 1. Answer **ALL** questions.
2. Each question carries **FIVE** marks. 2X5 =10

7. (a). By applying the dimensional analysis convert CGS unit of energy into SI units of energy.
(OR)
(b). Check the correctness of the following equations by applying Principle of homogeneity?
1) $s = ut + \frac{1}{2} at^2$ 2) $v^2 - u^2 = 2 as$
8. (a). Derive expression for magnitude and direction of resultant vector by applying parallelogram law of vectors.
(OR)
(b). Two vectors are $\vec{A} = 3\vec{i} - 3\vec{j} + \vec{k}$ and $\vec{B} = 4\vec{i} + 9\vec{j} + 2\vec{k}$. Solve $\vec{A} \times \vec{B}$

BOARD DIPLOMA EXAMINATION (C-21)
MID SEM –II
FIRST SEMESTER EXAMINATION
SC-103 - BASIC PHYSICS

Time: 1 Hour

Total Marks: 20

PART-A

- Instructions: 1. Answer **ALL** questions.
2. Each question carries **ONE** mark.

4X1 =4

1. Define angle of friction.
2. Define central force.
3. Define stress.
4. Define Reynold's number.

PART-B

- Instructions: 1. Answer **ALL** questions.
2. Each question carries **THREE** marks.

2X3 =6

5. (a). Explain the forces acting on the body moving up on a rough inclined plane.
(OR)
(b). Derive the relation between linear velocity and angular velocity.
6. (a). Explain the effect of temperature on viscosity of liquids and gases.
(OR)
(b). Explain Bernoulli's theorem.

PART-C

- Instructions: 1. Answer **ALL** questions.
2. Each question carries **FIVE** marks.

2X5 =10

7. (a). Develop expressions for maximum height and horizontal range of a projectile in oblique motion.
(OR)
(b). Develop the expression for angle of banking of roads.
8. (a). Develop formula for young's modulus of a wire having circular cross-sectional area.
(OR)
(b). Apply Bernoulli's theorem to dynamic aero foil lift.

BOARD DIPLOMA EXAMINATION, (C-21)
FIRST SEMESTER EXAMINATION
SC-103 - BASIC PHYSICS

Time: 2 Hours]

[Total Marks: 40

PART – A

- Instructions: 1. Answer **ALL** questions.
2. Each question carries **ONE** mark.

08X01=08

1. Define unit.
2. Define capillarity.
3. What is SI unit of power?
4. Define Hooke's law.
5. Name any one example of conservation of energy.
6. Define energy.
7. Define specific heat of a gas.
8. Define internal energy.

PART – B

- Instructions: 1. Answer **ALL** questions.
2. Each question carries **THREE** marks.

04X03=12

9(a). Explain Lami's theorem.

(OR)

9(b). Explain renewable and non-renewable energy sources with example.

10(a). Explain projectile motion with example.

(OR)

10(b). Explain Boyle's law and its limitations.

11(a). Show that $PE = mgh$

(OR)

11(b). Explain law of conservation of energy in the case of simple pendulum.

12(a). Explain first law of thermodynamics and list applications of it.

(OR)

12(b). Explain Boyle's law and its limitations.

PART – C

- Instructions: 1. Answer **ALL** questions.
2. Each question carries **FIVE** marks.

04X05 = 20

13(a). Develop expressions for magnitude and direction of resultant of two vectors using parallelogram law of vectors.

(OR)

13(b). Develop expression for kinetic energy of a body of mass 'm' moving with a velocity 'v'.

14(a). Develop a relation between linear velocity and angular velocity.

(OR)

14(b). apply first law of thermodynamics to isothermal and adiabatic processes.

15(a). Apply law of conservation of energy in the case of freely falling body.

(OR)

15(b). Explain Work-Energy theorem and develop the relation.

16(a). develop ideal gas equation

(OR)

16(b). Explain principle of bimetallic strip and apply it to electric water heater thermostat

SC-104 - GENERAL ENGINEERING CHEMISTRY

Course Title	General Engineering Chemistry	Course Code	SC-104
Semester	I	Course Group	Foundation
Teaching Scheme in Periods (L:T:P)	4:1:0	Credits	3
Methodology	Lecture +Tutorial	Total Contact Periods	75
CIE	60 Marks	SEE	40 Marks

Prerequisite: Basic knowledge of chemistry in secondary education.

Course Objectives: After studying this course, the student will be able to understand and appreciate the role of Chemistry and environmental studies in different spheres of industries.

Course Outcome: On successful completion of the course, the students will have ability to attain below Course Outcomes (CO):

CO1	Understand and explain the concept of atomic structure, chemical bonding, oxidation, reduction and oxidation number and apply the knowledge to solve engineering problems.
CO2	Understand and explain concept of mole, molarity, normality and colloids and apply the knowledge in various engineering areas.
CO3	Understand and explain the different theories of acids and bases, concept of pH, buffer action and apply the knowledge to solve engineering problems.
CO4	Understand the concept of Ecosystem, Biodiversity, Green Chemistry and Management of e-waste and take measures to support sustainable development.
CO5	Understand the concept of hardness and degree of hardness of water and apply the relevant water treatment methods to solve domestic and industrial problems.
CO6	Understand the concept of electrolysis, applications of electrolysis, Faraday's Laws of Electrolysis and apply the knowledge in extraction and purification of metals used for domestic and industrial purpose.

CO	PO1	PO2	PO3	PO4	PO5	PO6	PO7
CO1	3	1	-	-	-	-	2
CO2	3	1	-	-	1	-	2
CO3	3	1	-	-	-	-	2
CO4	3	-	-	-	3	-	3
CO5	3	1	-	-	1	-	2
CO6	3	1	-	-	-	-	2

COURSE CONTENTS

UNIT-I: Fundamentals of Chemistry

13 Periods

Atomic Structure: Introduction – Atomic number – Mass number- Isotopes and Isobars - Bohr's Atomic Theory - Orbitals - Shapes of s, p and d orbitals – Aufbau principle - Hund's rule - Pauli's exclusion principle - Electronic configuration of elements

Chemical Bonding: Introduction – Electronic theory of valency - Types of chemical bonds - Ionic, Covalent, Co-ordinate covalent, Metallic and Hydrogen bonds with examples - Properties of Ionic and Covalent compounds - Types of Hydrogen bonds – Effect of hydrogen bonding on physical properties.

Oxidation-Reduction: Electronic concept of Oxidation, Reduction, Oxidation Number - Calculations.

UNIT-II: Solutions and Colloids

12 Periods

Introduction - Solution – Solubility - Classification of solutions based on physical state- Atomic weight - Molecular weight ,Equivalent weight - Mole concept – Molarity – Normality - Numerical problems on mole, molarity and normality – Colloids - Types of colloids- Lyophilic and Lyophobic colloids - Protective Colloids - Gold number - Properties of Colloids - Industrial applications of colloids.

UNIT-III: Acids and Bases

13 Periods

Introduction - Theories of acids and bases and limitations - Arrhenius theory - Bronsted - Lowry theory - Lewis acid base theory - Ionic product of water - pH and related numerical problems - Buffer solutions- buffer action - Applications of buffer solution - Ostwald's theory of indicators.

UNIT-IV: Environmental Science

12Periods

Introduction - Environment -Scope and importance of environmental studies- Important terms -Concept of ecosystem - Producers, consumers and decomposers - Food chain - Food web - Carbon and nitrogen cycles - Biodiversity, definition and threats to Biodiversity- Forest resources- Deforestation – Green Chemistry – e-waste – Management of e-waste.

UNIT-V: Water Technology

13 Periods

Introduction -Soft and hard water - Causes of hardness – Types of hardness - Disadvantages of hard water using in industries - Degree of hardness - Softening methods - Permutit process - Ion exchange process - Drinking water - Municipal treatment of water for drinking purpose – Osmosis - Reverse Osmosis - Advantages of Reverse osmosis – Desalination by Electro dialysis – Defluoridation – Nalgonda Technique.

UNIT-VI: Electrochemistry:

12 Periods

Conductors, insulators, electrolytes – Types of electrolytes - Arrhenius theory of electrolytic dissociation - Electrolysis – Electrolysis of fused NaCl and aqueous NaCl – Applications of electrolysis - Faraday's laws of electrolysis- Numerical problems.

Reference Books:

1. Engineering chemistry – Jain & Jain – Dhanpat Rai Publishing Company.
2. A Text book of Engineering Chemistry – S.S.Dara – S.Chand Publications.
3. Environmental Studies – A.K.De.
4. Environmental Studies, R. Rajagopalan, 2nd Edition, 2011, Oxford University Press
5. Intermediate Chemistry I and II – Telugu Academy TS
6. Engineering chemistry – Prasanta Rath, B. Ramadevi, Ch. Venkataramana Reddy& Subhendu Chakroborty – CENGAGE

E - learning links:

1. <https://iupac.org/>
2. <https://www.khanacademy.org/>
3. www.nptel.ac.in
4. www.chemguide.co.uk
5. www.visionlearning.com

Specific Learning Outcomes

Upon completion of the course, the student will have ability to

UNIT- I: FUNDAMENTALS OF CHEMISTRY

- 1.1 Explain the concept of atomic number, mass number, isotopes and isobars
- 1.2 State the postulates of Bohr's atomic theory and its limitations
- 1.3 Define Orbital.
- 1.4 Draw and explain the shapes of s, p and d orbitals.

- 1.5 Distinguish between Orbit and Orbital
- 1.6 Make use of 1. Aufbau principle, 2. Hund's rule and 3. Pauli's exclusion principle in writing electronic configuration of elements.
- 1.7 Write the electronic configuration of elements up to atomic number 30
- 1.8 Define chemical bond.
- 1.9 Write the Postulates of Electronic theory of valency.
- 1.10 List the types of chemical bonds viz., Ionic, Covalent, Co-ordinate covalent, Metallic and Hydrogen bond.
- 1.11 Define ionic bond and explain the Ionic bond formation in NaCl, MgO, CaCl₂, Na₂O, K₂O.
- 1.12 List and explain the properties of ionic compounds.
- 1.13 Explain covalent bond formation in Hydrogen, Oxygen, Nitrogen, Ammonia, Methane, Ethylene, and Acetylene molecules using Lewis Dot Method.
- 1.14 List and explain the properties of covalent compounds.
- 1.15 Compare the properties of ionic compounds and covalent compounds.
- 1.16 Define metallic bond and explain with free electron theory/ electron sea model.
- 1.17 Define hydrogen bond
- 1.18 Explain inter molecular hydrogen bonding in HF, H₂O, NH₃
- 1.19 Explain inter and intra molecular hydrogen bonding in Salicylaldehyde and Nitrophenol.
- 1.20 Explain the effect of hydrogen bonding on the boiling point.
- 1.21 Explain the effect of hydrogen bonding on solubility of alcohols
- 1.22 Understand the electronic concept of oxidation, reduction and redox reaction.
- 1.23 Define oxidation number
- 1.24 List the rules for calculation of oxidation number.
- 1.25 Apply the rules to calculate the oxidation number.

UNIT-II: SOLUTIONS AND COLLOIDS

- 2.1 Define the terms 1.Solution, 2.Solute and 3.Solvent.
- 2.2 Define solubility.
- 2.3 Explain the factors effecting solubility.
- 2.4 Define aqueous solution and alcoholic solution.
- 2.5 Compare unsaturated, saturated and super saturated solutions.

- 2.6 Classify the solutions based on the physical state of solute and solvent.
- 2.7 Define atomic weight, molecular weight and equivalent weight.
- 2.8 Calculate the molecular weight and the equivalent weights of acids, bases and salts.
- 2.9 Define mole.
- 2.10 Explain mole concept and solve the numerical problems.
- 2.11 Define and explain molarity and normality.
- 2.12 Derive the relationship between molarity to normality.
- 2.13 Solve numerical problems on molarity and normality of a solution and mixture of solutions.
- 2.14 Define and explain colloids, dispersed phase and dispersion medium with examples.
- 2.15 List the types of colloids with examples.
- 2.16 Distinguish between Lyophilic Colloid and Lyophobic Colloid.
- 2.17 Understand the Protective Colloids and Gold number. (Elementary level)
- 2.18 Explain the properties of colloids: Tyndall effect, Brownian movement and Coagulation.
- 2.19 State and explain the industrial applications of colloids.

UNIT-III: ACIDS AND BASES

- 3.1 Explain Arrhenius theory of acids and bases.
- 3.2 State the limitations of Arrhenius theory of acids and bases
- 3.3 Explain Bronsted - Lowry theory of acids and bases.
- 3.4 State the limitations of Bronsted - Lowry theory of acids and bases.
- 3.5 Explain Lewis theory of acids and bases.
- 3.6 List out the types of Lewis acids and bases.
- 3.7 State the limitations of Lewis theory of acids and bases.
- 3.8 Explain the ionic product of water and solve the problems.
- 3.9 Define pH and explain Sorenson's pH scale.
- 3.10 Solve the numerical problems on pH (Strong acids and bases).
- 3.11 Define buffer solutions and give examples of acidic and basic buffers.
- 3.12 State the applications of buffer solutions.
- 3.13 Explain the buffer action of acidic (acetate buffer) and basic (ammonium buffer) buffers.
- 3.14 Explain the Ostwald's theory of indicators with phenolphthalein and methyl orange indicators as an example.

UNIT-IV: ENVIRONMENTAL SCIENCE

4.1 Define the term environment

4.2 Explain the importance of the following

1) Lithosphere, 2) Hydrosphere, 3) Atmosphere, 4) Biosphere,

4.3 Define and understand the following terms

i) Pollutant, ii) Contaminant iii) Pollution, iv) Receptor, v) Sink,
vi) Particulates, vii) Threshold limit value (TLV), viii) Dissolved oxygen
(DO), ix) BOD and x) COD

4.4 Define Ecosystem. Understand the biotic and the abiotic components of ecosystem.

4.5 Define and explain the following biotic components with examples

1) Producers, 2) Consumers and 3) Decomposers

4.6 Explain the food chain of land, aquatic and forest.

4.7 Explain the Food web.

4.8 Understand the Carbon and Nitrogen cycles.

4.9 Define and explain biodiversity

4.10 Explain the threats to biodiversity.

4.11 Explain conservation of biodiversity.

4.12 Describe the forest and list the uses of forests.

4.13 Define the deforestation and explain the causes, effects and control of deforestation.

4.14 Understand the concept of Green Chemistry – Its principles and benefits.

4.15 Define e-waste

4.16 Explain the effect of e-waste on environment.

4.17 State the effects of chemicals released from e-waste on human beings.

4.18 Explain the management of e-waste.

4.19 Understand and explain the advantage of recycling of e-waste.

UNIT V: WATER TECHNOLOGY

5.1 State the various sources of water.

5.2 Define the terms soft water and hard water with examples

5.3 Define hardness of water.

5.4 Explain temporary and permanent hardness of water.

5.5 List the usual chemical compounds causing hardness (with Formulae)

5.6 Explain the disadvantages of using hard water in industries.

- 5.7 Define Degree of hardness, units of hardness in ppm , mg/L and numerical problems related to hardness.
- 5.8 Explain the methods of softening of hard water:
- a) Removal of temporary hardness by i) Boiling ii) Clark's Method
 - b) Removal of total hardness by i) Permutit process ii) Ion-Exchange process.
- 5.9 List the essential qualities of drinking water.
- 5.10 Explain Municipal treatment of water for drinking purpose.
- 5.11 Define Osmosis and Reverse Osmosis (RO).
- 5.12 List the applications and advantages of RO.
- 5.13 Explain the process of desalination of sea water by Electro dialysis.
- 5.14 Explain the process of defluoridation by using Nalgonda Technique.

UNIT VI: ELECTROCHEMISTRY

- 6.1 Define the terms 1. Conductor, 2. Insulator, 3. Electrolyte and 4. Non-electrolyte
- 6.2 Types of electrolytes - strong and weak electrolytes with examples.
- 6.3 Distinguish between metallic conductors and Electrolytic conductors.
- 6.4 Explain the Arrhenius theory of electrolytic dissociation
- 6.5 Define electrolysis.
- 6.6 Explain the electrolysis of fused NaCl and aqueous NaCl (Nelson Cell).
- 6.7 Explain the applications of Electrolysis - Electrolytic refining of metal (Copper)
- Electroplating.
- 6.8 Explain Faraday's laws of electrolysis
- 6.9 Define chemical equivalent, electrochemical equivalent.
- 6.10 Know the relationship between chemical equivalent and electrochemical equivalent
- 6.11 Solve the numerical problems based on Faraday's laws of electrolysis

Blue Print

MID SEM-I EXAM

S.No	Unit Name	R	U	A	Remarks
1	Unit-I	1, 2	5(a) 5(b)	7(a) 7(b)	
2	Unit-II	3, 4	6(a) 6(b)	8(a) 8(b)	
Total Questions		4	4	4	
MID SEM –II EXAM					
S.No	Unit Name	R	U	A	Remarks
1	Unit-III	1, 2	5(a) 5(b)	7(a) 7(b)	
2	Unit-IV	3, 4	6(a) 6(b)	8(a) 8(b)	
Total Questions		4	4	4	

Semester End Examination

Sl No	Unit No.	Questions to be set for SEE			Remarks		
		R	U	A			
1	I	4	1	9(a)	13(a)		
2	II			10(a)	14(a)		
3	III		3	5, 6	9(b)	13(b)	
4	IV				11(a)	15(a)	
5	V				11(b)	15(b)	
6	VI		7,8	10(b)	14(b)		
		12(a)		16(a)			
Total Questions		8		8	8		

Legend:	Remembering (R)	1 Mark
	Understanding (U)	3 Marks
	Application (A)	5 Marks

BOARD DIPLOMA EXAMINATIONS (C21)
I SEMESTER, MIDSEM – I
SC-104 - GENERAL ENGINEERING CHEMISTRY

Time: 1 Hour

Max. Marks: 20

PART – A

Instructions: Answer **all** questions. Each question carries **one** mark.
marks

4 X 1 = 4

1. State Hund's rule.
2. Write the electronic configuration of Cr.
3. Define mole.
4. What are colloids?

PART – B

Instructions: Answer **the following** questions. Each question carries **three** marks

2 x 3 = 6 Marks

5. a. Draw the shapes of s and d orbitals.
(OR)
b. Explain the covalent bond formation in Nitrogen molecule by Lewis dot method.
6. a. Classify solutions based on their physical state.
(OR)
b. Compare any three properties of lyophilic and lyophobic colloids.

PART – C

Instructions: Answer **the following** questions. Each question carries **five** marks

2 x 5 = 10 Marks

7. a. Explain the effect of hydrogen bonding on boiling point with examples.
(OR)
b. What is oxidation number? Find the oxidation number of 'S' in H₂SO₄ and 'Mn' in KMnO₄.
8. a. Define molarity. Find the weight of H₂SO₄ required to prepare 400 ml of 0.5M solution.
(OR)
b. Define normality. Calculate the normality of 500 ml solution containing 0.53 grams of Na₂CO₃.

BOARD DIPLOMA EXAMINATIONS (C21)
I SEMESTER, MIDSEM – II
SC-104 - GENERAL ENGINEERING CHEMISTRY

Time: 1 Hour

Max. Marks: 20

PART – A

Instructions: i. Answer **all** questions. Each question carries **one** mark.

4 X 1 = 4 marks

1. What is conjugate acid base pair?
2. Define ionic product of water.
3. Define an ecosystem.
4. What is threshold limit value?

PART – B

Instructions: Answer **the following** questions. Each question carries **three** marks

2 x 3 = 6 Marks

5. a. What are the limitations of Arrhenius theory of acids and bases?
(OR)
b. Explain the neutralization according to Lewis theory of acids and bases with an example.
6. a. Explain the terms producers, consumers and decomposers with example.
(OR)
b. Explain the aquatic food chain.

PART – C

Instructions: Answer **the following** questions. Each question carries **five** marks

2 x 5 = 10 Marks

7. a. Define pH. Find the pH of 0.5M NaOH solution.
(OR)
b. What are buffer solutions? State the applications of buffer solutions.
8. a. What is Biodiversity and how to conserve the Biodiversity.
(OR)
b. What is deforestation? What are its consequences?

BOARD DIPLOMA EXAMINATIONS (C21)
I SEMESTER END EXAMINATION
SC-104 - GENERAL ENGINEERING CHEMISTRY

Time: 2 Hours

Max. Marks: 40

PART-A

Instructions: Answer **all** questions. Each question carries **one** mark.

8 X 1 = 8 marks

1. Define atomic mass number.
2. What is biodiversity?
3. Define degree of hardness of water.
4. What are buffer solutions?
5. Define soft water and hard water.
6. Name the salts responsible for temporary hardness of water.
7. Define the terms conductor and insulator.
8. What is an electrolyte?

PART – B

Instructions: Answer **the following** questions. Each question carries **three** marks

4 x 3 = 12 Marks

9. a. State and explain Hund' rule.
or
b. Write any six essential qualities of drinking water.
10. a. Explain the terms producers, consumers and decomposers with example.
or
b. What are strong and weak electrolytes? Give examples.
11. a. Define reverse osmosis and state its advantages.
or
b. Compare temporary and permanent hardness of water.
12. a. Distinguish between metallic and electrolytic conductors.
Or
b. State Faraday's Laws of electrolysis.

PART – C

Instructions: Answer **the following** questions. Each question carries **five** marks 4 x 5 =20
Marks

13. a. Find the molarity and normality of the two litres of solution containing 10.6 grams of Na_2CO_3 .

or

b. Calculate the temporary and permanent hardness of water containing the following salts per litre

i. $\text{Ca}(\text{HCO}_3)_2 = 32.4 \text{ mg}$, ii. $\text{Mg}(\text{HCO}_3)_2 = 29.2 \text{ mg}$, iii. $\text{CaSO}_4 = 13.6 \text{ mg}$, iv. $\text{MgCl}_2 = 19 \text{ mg}$

14. a. Explain Lewis theory of acids and bases.

or

b. Explain the process of electrolysis of fused NaCl .

15. a. Explain the permutit process of softening of hard water with a neat diagram.

or

b. What are the disadvantages of using hard water in industries?

16. a. Explain the process of electrolytic refining of copper.

Or

b. Calculate the weight of Al deposited on the cathode if 0.5 amperes of electric current is passed through AlCl_3 solution for 1 hour.

CH-105 - MATERIALS TECHNOLOGY

Course Title	Materials Technology	Course Code	CH-105
Semester	I	Course group	Core
Teaching Scheme in Hrs (L:T:P)	4:1:0	Credit	3
Type of course	Lecture + assignments	Total Contact Hours	75
CIE	60 marks	SEE	40 marks

Pre requisites:

This course requires the basic knowledge of Physics, Chemistry, structures of materials at secondary school level

Course Outcomes

CO1 :	Demonstrate the mechanical properties of materials and destructive and non destructive Testing of materials
CO2 :	Analyze the Structure of materials, basic concepts of crystalline materials like unit cell FCC,BCC, HCP
C03	Explain Iron carbon equilibrium diagram representing different phases
CO4 :	Explain different methods of manufacture of Iron and Steel
CO5 :	Discuss the need of alloying steel and non ferrous metals and select the alloys for specific applications
CO6 :	Study the various types of Miscellaneous materials and basic knowledge of corrosion

Course Content and Blue Print of Marks for SEE

Unit No	Unit Name	Periods	Questions to be set for SEE				
			R	U	A		
1	Introduction, Mechanical properties of metals & Testing of materials	15	Q4	Q1	Q9(a)	Q13(a)	
2	Structure of metals and alloys.	8		Q2	Q10(a)	Q14(a)	
3	Thermal equilibrium diagram	10					
4	Production of Iron and Steel	15		Q3	Q5,Q6	Q9(b), Q11(a), Q11(b)	Q14(b), Q15(a), Q15(b)
5	Plain carbon steels and alloy steels & Non ferrous metals and their alloys	12					
6	Miscellaneous materials and introduction to corrosion	15					
Total		75	8	8	8		

COURSE CONTENTS

UNIT-1: Introduction, Mechanical properties of metals & Testing of materials

Duration: 15 Periods (L: 12 – T:3)

Definition of Engineering materials, Classification of Engineering materials - need and applications, Define the terms strength of materials, stress, strain, elasticity, tensile and compressive strength, ductility, hardness, toughness, brittleness, impact strength, fatigue and creep strength- various destructive testing methods. Determination of Tensile strength & compressive strength by UTM - Hardness by Brinell & Rockwell testing machines- Impact strength by Izod and Charpy testing machines- various non destructive testing methods.

UNIT-2: Structure of metals and alloys

Duration: 08 Periods (L: 6 – T:2)

Unit cell – space lattice – FCC, BCC, HCP space lattices – formation of grains by dendritic growth – effect of grain size on mechanical properties – factors promoting grain size – Phenomenon of crystallization

UNIT -3: Thermal equilibrium diagram:

Duration: 10 Periods (L: 8 – T:2)

Cooling curve of pure iron.-Allotropic forms of pure iron, Iron – carbon thermal equilibrium diagram

Peritectic, Eutectic and Eutectoid points in iron carbon Equilibrium diagram.

UNIT -4: Production of Iron and Steel

Duration: 15 Periods (L: 10– T:5)

Raw materials required for Production of iron- various methods of manufacture of steel and Iron – Production of Pig Iron by Blast furnace – Production of Steel by Bessemer converter and L-D converter- Production of cast iron by cupola furnace- Properties and applications of different types of cast iron.

UNIT 5: Plain carbon steels and alloy steels & Non ferrous metals and their alloys:

Duration: 12 Periods (L: 10 -T:2)

Classification and application of plain carbon steels –Need for alloying the steels - industrial applications of alloy steels-Selection of alloy steels for suitable engineering applications-

Importance of various non ferrous metals and alloys of aluminum, copper, nickel, lead, tin, zinc, titanium, zirconium, - properties of aluminum, copper, zinc, tin, lead and their applications — types of Nickel alloys (Monel, Hastalloy) and copper alloys (Brasses and Bronzes), their properties and applications.

UNIT 6: Miscellaneous materials and introduction to corrosion

Duration: 15 Periods (L: 12 – T:3)

Importance of glass - types and applications – properties and applications of Carbon and Graphite – application of polymers – composition, properties, applications of stoneware – applications of asbestos, rubber, Elastomers, Fibre glass, reinforced plastics, Refractories, Ceramics, Composites, Nano- materials - corrosion-causes of corrosion- Types of corrosion – prevention methods of corrosion.

Specific Learning Outcomes

1.0 Mechanical properties of metals & Testing of materials

1.1 Define and Engineering materials

1.2 Need of Engineering materials and their applications.

1.3 Define the following properties of materials

- a. Stress & strain.
- b. Tensile and compressive strength
- c. Hardness and Toughness
- d. Brittleness
- e. Impact strength
- f. Elasticity
- g. Ductility
- h. Fatigue and creep strength

1.4 Appraise about the destructive methods of testing and non-destructive methods of testing to identify various defects of materials and their applications.

1.5 Determination of tensile strength and compressive strength by Universal Testing Machine (UTM)

1.6 Determine Hardness by Brinell hardness testing machine and Rockwell hardness testing machine.

1.7 Determine impact strength by Izod and Charpy's impact testing machines.

1.8 Identify the procedures to detect the internal defects of metal by X-ray , y-ray (Gamma ray) and ultrasonic tests.

2.0 Understand the structure of metals and non-metals.

- 2.1 Define Unit cell and space lattice.
- 2.2 Understand the arrangement of atoms in FCC (Face Centered Cubic), BCC (Body Centered Cubic) and HCP (Hexagonal close packed) systems and give examples.
- 2.3 State the effect of grain size on mechanical properties.
- 2.4 Identify the factors promoting grain size.

3.0 Thermal equilibrium diagram:

- 3.1 Explain Cooling curve for pure iron
- 3.2 State Allotropic forms of pure iron
- 3.3 Draw Iron – Carbon thermal equilibrium diagram.
- 3.4 Explain different phases on equilibrium diagram
- 3.5 Locate the peritectic, eutectic, eutectoid points from the Iron – Carbon diagram.

4.0 Methods of producing Iron and steel

- 4.1 Name the various raw materials required for the production of iron.
- 4.2 Name the various methods of manufacturing of steel and iron.
- 4.3 Explain the production of Pig iron by Blast Furnace
- 4.4 Explain the manufacturing methods of steel
- 4.5 Demonstrate manufacture of steel by Bessemer converter
- 4.6 Demonstrate manufacture of steel by L-D converter and electric arc furnace
- 4.7 Explain the production of Cast iron by Cupola Furnace
- 4.8 Classify cast iron such as white, gray & malleable Cast iron.
- 4.9 Demonstrate the properties and applications of different types of cast iron.

5.0 Plain carbon steels and alloy steels and non – ferrous metals and their alloys

- 5.1 State the classification of plain carbon steels.
- 5.2 Describe the need for alloying the steel with other elements.
- 5.3 State the composition, properties and industrial applications of alloy steels.
- 5.4 Select the proper alloy steel for the given engineering application.
- 5.5 State the importance of various non – ferrous metals and alloys – aluminum, copper, Nickel, lead, Tin, Zinc, titanium, Zirconium
- 5.6 Discuss the properties of aluminum, copper, zinc, tin, lead, and their applications.
- 5.7 State the effects of the alloying elements (a) Copper (b) Silica (c) Magnesium (d) Manganese with aluminum.
- 5.8 Illustrate types of copper alloys (Brasses & Bronzes), their properties and applications.
- 5.9 Illustrate types of Nickel alloys (Monel, Hastalloy), their properties and applications.

6.0 Miscellaneous materials, Corrosion and its prevention

- 6.1 State the importance of glass and its lining as materials of construction for the process equipments.
- 6.2 State the types of glass and their applications
- 6.3 State the properties and applications of carbon and graphite.
- 6.4 State composition, properties and applications of stoneware.
- 6.5 Explain application of Asbestos, Rubber, Elastomers, and Polymers.
- 6.6 Demonstrate about Refractories and their applications
- 6.7 Explain about Glass ceramics, Ceramites and Glass wool.
- 6.8 Define corrosion and explain the causes of corrosion.
- 6.9 Explain electro chemical theory of corrosion
- 6.10 Illustrate (a) Electrode potential (b) Passivity (c) Electro chemical series (d) polarization.
- 6.11 Analyse different types of corrosion (a) uniform corrosion (b) stress corrosion (c) pitting (d) hydrogen attack (e) bimetallic corrosion (f) grain boundary corrosion (g) Fatigue corrosion
- 6.12 Demonstrate the methods of prevention of corrosion by (a) Proper selection of materials (b) Organic coatings (c) Inorganic coatings (d) Anodic and cathodic protection (e) Anodic and cathodic inhibitors.

Suggested Student Activities for Induction Program

	Forenoon	Afternoon
Day1	Registration	Class work as per Time table Drawing and Basic workshop practice classes may be conducted
Day2	Rules and Regulations	
Day3	Getting acquainted with Head and faculty	
Day4	Familiarization with Institutional facilities	
Day5	Interaction with Class teacher and Seniors	
Day6	Introducing the mentor	
Day7	Parent –Teacher meeting	

Suggested Student Activities:

Other than the class room and laboratory learning following are the suggested student related co curricular activities which can be undertaken to accelerate the attainment of the various outcomes in this course

1. Enlist the different types of metals , non metals in Chemical Laboratories
2. Visit nearby metal foundry
3. Prepare the chart for various grades of steel
4. Draw the atomic structure of various metals. Display charts in Classroom/Laboratory and prepare models
5. Draw Iron - carbon equilibrium diagram and display chart in class room
6. Group discussion/Quiz
7. Surprise test

Suggested Software / E-Learning references:

- i. <https://en.wikipedia.org/wiki/materials-science>
- ii. <http://mse.stanford.edu>
- iii. <http://ocw.mit.edu/courses/materials-science> and engineering
- iv. www.nptel.ac.in

Suggested Learning Resources / Reference books

1. Engineering Chemistry by Jain & Jain
2. Engineering Materials by Pakirappa
3. Engineering Metallurgy by Higgins.
4. Material Science by S.K Hazra Chowdary.
5. Material science and Metallurgy by O.P.Khanna
6. Engineering Materials by Rangawal S.C

MID SEM-I EXAM

S.No	Unit Name	R	U	A	Remarks
1	Unit-I	1, 2	5(a) 5(b)	7(a) 7(b)	
2	Unit-II	3, 4	6(a) 6(b)	8(a) 8(b)	
Total Questions		4	4	4	

MID SEM –II EXAM

S.No	Unit Name	R	U	A	Remarks
1	Unit-III	1, 2	5(a) 5(b)	7(a) 7(b)	
2	Unit-IV	3, 4	6(a) 6(b)	8(a) 8(b)	
Total Questions		4	4	4	

Semester End Examination

Sl No	Unit No.	Questions to be set for SEE			Remarks		
		R	U	A			
1	I	4	1	9(a)	13(a)		
2	II			10(a)	14(a)		
3	III		3	5, 6	9(b)	13(b)	
4	IV				11(a)	15(a)	
5	V	11(b)			15(b)		
6	VI	3	7,8	10(b)	14(b)		
				12(a)	16(a)		
				12(b)	16(b)		
Total Questions		8	8	8			

State Board of Technical Education and Training, Telangana

Model Question paper

DCHE I Semester Mid Semester-I Examination

Course Code: CH-105

Course Name: MATERIALS TECHNOLOGY

Duration:1 hour

Max.Marks:20

PART-A

Answer all questions, Each Question carries one mark
Marks

4x1 = 4

1. What are engineering materials? Give Examples.
2. Define Hardness.
3. Define unit cell.
4. Draw the structures of F.C.C

PART-B

Answer two questions. Each question carries three marks

2x 3 = 6 Marks

5(a) Write the Classification of Engineering Materials

(or)

5(b) What is the difference between destructive testing and Non-destructive testing?

6(a) What are the factors that promoting grain size?

(or)

6(b) What is the effect of grain size on mechanical properties?

PART-C

Answer two questions. Each question carries five marks

2x 5 = 10 Marks

7(a). Determine the hardness of the given sample using Brinell hardness testing machine.

(or)

7(b). Explain briefly about UTM with the help of a neat sketch with stress - strain diagram.

8(a). Explain the phenomenon of crystallization

(or)

8(b). What is space lattice? Draw the structure of BCC.

State Board of Technical Education and Training, Telangana

Model Question paper

DCHE I semester Mid Semester-II Examination

Course Code: CH-105

Duration: 1 hour

Course Name: MATERIALS TECHNOLOGY

Max.Marks:20

PART-A

Answer all questions, Each Question carries one mark $4 \times 1 = 4$ Marks

- 1) What is Pearlite?
- 2) What is an alloy?
- 3) What is the function of coke in the production of Blast furnace?
- 4) Draw a neat sketch of L-D converter.

PART-B

Answer two questions. Each question carries three marks

$2 \times 3 = 6$ Marks

5(a). Sketch the cooling curve of a pure metal.

(or)

5(b) What is Peritectic reaction? Explain about the formation of austenite

6(a). Draw the neat diagram of blast furnace.

(or)

6(b) Write the advantages of making steel in L-D Converter.

PART-C

Answer two questions. Each question carries five marks

$2 \times 5 = 10$ Marks

7(a) Draw the iron –carbon thermal equilibrium diagram

(or)

7(b) Explain Allotropic forms of pure iron with a line sketch

8(a) Explain the method of manufacture of steel by acidic Bessemer converter

(or)

8(b). Explain the method of manufacture of steel by L- D converter

PART-C

INSTRUCTIONS: 1. Answer any FOUR questions
2. Each question carries FIVE marks.

04x5=20

13 (a). How do you determine the hardness of the material by Brinell hardness testing machine?

Or

13 (b). What are the different types of copper alloys? Write any one of them with applications.

14 (a). Write the advantages of making steel in L-D Converter.

Or

14 (b) . Write the properties and applications of ceramics.

15 (a). What are the different types of copper alloys? Write any one of them with applications

Or

15 (b). Name any two important alloys of nickel and write their properties and applications.

16 (a). Write the properties and applications stoneware.

Or

16 (b). What are the various types of corrosion? Classify them

ME-106 BASIC ENGINEERING DRAWING

(This Course is Common to all programs of Diploma in Engineering offered by the State Board of Technical Education, Hyderabad, Telangana State)

Course Title :	Basic Engineering Drawing	Course Code	ME-106
Semester	I	Course Group	Core
Teaching Scheme in Pds (L :P)	1:0:2	Credits	1.5
Methodology	Lecture + Practice	Total Contact Pds:	45
CIE	60 Marks	SEE	40 Marks

Prerequisites: No prerequisites are required to learn this course.

Course Objectives

The Course is aimed at developing basic drawing skills so as to enable them to use these skills in the preparation of engineering drawings, their reading and interpretation.

Course Outcomes

Upon completion of the subject the student shall be able to

CO1	Recognize the importance of Engineering Drawing and usage of the drawing instruments.
CO2	Practice free hand lettering & numbering in different styles.
CO3	Recognize the importance of Dimensioning and Acquiring the knowledge of different methods of dimensioning systems.
CO4	Appreciate the usage of engineering curves such as tangent lines, tangent arcs, parabola, hyperbola, ellipse, involute, cycloid and helix in various engineering applications and draw the above said curves
CO5	Realize the concept of projection and attain visualization projection of points, Lines and Planes. The student will also be able to draw the views related to projection of Points, Lines and Planes.
CO6	Analyze the concept of orthographic projections and student will be able to draw orthographic views of an object from its pictorial drawing.

Blueprint for Marks in SEE

Unit No	Name of the Unit	Periods	Questions to be set for SEE		
			R	U	A
			PART-A (2M Questions)		PART-B (6M Questions)
1, 2 & 3	Importance of Engineering Drawing and Instruments, Free hand lettering and Numbering and Dimensioning Practice	09	Q1	Q9(a)	
4a.	Geometric constructions up to construction of polygons	06	Q2	Q9(b)	
4b.	Geometric constructions contd., Conical curves and Special curves	06	Q3	Q10(a)	
5	Projection of points, Lines, and Planes	09	Q4	Q10(b)	
6	Orthographic projections	15	Q5, Q6, Q7, Q8	Q11(a), Q11(b), Q12(a), Q12(b)	
Total Periods / Total Questions		45	8	4	
<p>[R: Remembering; U: Understanding – 2 Marks; A: Application – 6 Marks]</p> <p><u>Note: Question Paper consists PART – A and PART-B</u> PART – A consists of 8 questions) and student has to answer ALL questions, each question carries 2 marks. (8x2 = 16) PART – B consists of 4 questions and student has to attempt ALL questions, each question carries 6 marks (4x6=24)</p>					

CIE Question Paper Pattern and Syllabus

Unit No	Name of the Unit	Periods	Questions to be set for CIE		
			R	U	A
			PART-A (2M Questions)		PART-B (6M Questions)
Mid Sem – I Exam					
1, 2 & 3	Importance of Engineering Drawing and Instruments, Free hand lettering and Numbering and Dimensioning Practice	09	Q1, Q2	Q5(a), Q5(b)	
4a.	Geometric constructions up to construction of polygons	06	Q3, Q4	Q6(a), Q6(b)	
Total			4	2	
Mid Sem – II Exam					
4b.	Geometric constructions contd., Conical curves and Special curves	06	Q1, Q2	Q5(a), Q5(b)	
5	Projection of points, Lines, and Planes	09	Q3, Q4	Q6(a), Q6(b)	
Total			4	2	
<p>[R: Remembering; U: Understanding – 2 Marks; A: Application – 6 Marks]</p> <p><u>Note: Question Paper consists PART – A and PART-B</u> PART – A consists of 4 questions and student has to answer ALL questions, each question carries 2 marks. (4x2 = 8) PART – B consists of 2 questions and student has to attempt ALL questions, each question carries 6 marks (2x6=12)</p>					

Course Contents

NOTE:

1. B.I.S Specification should invariably be followed in all the topics.
2. A-3 Size Drawing Sheets are to be used for all Drawing Practice Exercises.

1.0 The importance of Engineering Drawing and Engineering Instruments

Explanation of the scope and objectives of the subject of Engineering Drawing Its importance as a graphic communication -Need for preparing drawing as per standards – SP-46 –1988 – Mention B.I.S - Role of drawing in -engineering education – Link between Engineering drawing and other subjects of study.

Engineering drawing Instruments

Classifications: Basic Tools, tools for drawing straight lines, tools for curved lines, tools for measuring distances and special tools like mini drafter & drafting machine – Mentioning of names under each classification and their brief description -Scales: Recommended scales reduced & enlarged -Lines: Types of lines, selection of line thickness - Selection of Pencils -Sheet Sizes: A0, A1, A2, A3, A4, A5, Layout of drawing sheets in respect of A0, A1, A3 sizes, Sizes of the Title block and its contents, Care and maintenance of Drawing Sheet, Drawing plate:

Lay out of sheet – as per SP-46-1988 to a suitable scale.

2.0 Free hand lettering & numbering

Importance of lettering – Types of lettering -Guide Lines for Lettering
Practicing of letters & numbers of given sizes (7mm, 10mm and 14mm)
Advantages of single stroke or simple style of lettering - Use of lettering stencils

3.0 Dimensioning practice

Purpose of engineering Drawing, Need of B.I.S code in dimensioning -Shape description of an Engineering object -Definition of Dimensioning size description - Location of features, surface finish, fully dimensioned Drawing -Notations or tools of dimensioning, dimension line extension line, leader line, arrows, symbols, number and notes, rules to be observed in the use of above tools -Placing dimensions: Aligned system and unidirectional system (SP-46-1988)-Arrangement of dimensions Chain, parallel, combined progressive, and dimensioning by co-ordinate methods-The rules for dimensioning standard, features: Circles (holes) arcs, angles, tapers, chamfers, and dimension of narrow spaces.

4.0 Geometric Construction

Division of a line: to divide a straight line into given number of equal parts internally examples in engineering application. Construction of tangent lines: to draw tangent lines touching circles internally and externally.

Construction of tangent arcs

- a) To draw tangent arc of given radius to touch two lines inclined at given angle (acute, right and obtuse angles).
- b) Tangent arc of given radius touching a circle or an arc and a given line.
- c) Tangent arcs of radius R, touching two given circles internally and externally.

Construction of polygon: construction of any regular polygon of given side length using general method.

Conical Curves: Explanation of Ellipse, Parabola, Hyperbola, as sections of a double cone and a loci of a moving point, Eccentricity of above curves – Their Engg. application viz. Projectiles, reflectors, P-V Diagram of a hyperbolic process.

Conical Curves: Construction of any conic section of given eccentricity by general method.

Construction of ellipse by concentric circles method.

Construction of parabola by rectangle method.

Construction of rectangular hyperbola.

Special Curves: Involute, Cycloid and Helix, explanations as locus of a moving point, their engineering application, viz, Gear tooth profile, screw threads, springs etc. - their construction

5.0 Projection of points, lines and planes

Projecting a point on two planes of projection -Projecting a point on three planes of projection -Projection of straight line.

- a) Parallel to both the planes.
- b) Perpendicular to one of the planes.
- c) Inclined to one plane and parallel to other planes.

Projection of regular planes.

- a) Plane perpendicular to HP and parallel to VP and vice versa.
- b) Plane perpendicular to HP and inclined to VP and vice versa.

6.0 Orthographic Projections

Meaning of orthographic projection -Using a viewing box and a model – Number of views obtained on the six faces of the box - Legible sketches of 3 views for describing object -Concept of front view, top view, and side view for sketching these views of engineering objects - Explanation of first angle projection. – Positioning of three views in First angle projection - Projection of points as a means of locating the corners of the surfaces of an object – Use of miter line in drawing a third view when other two views are given -Method of representing hidden lines -Selection of minimum number of views to describe full object.

Reference Books

1. Engineering Drawing by N.D. Bhatt (Charotar Publishing House Pvt. Ltd.)
2. Engineering Drawing by Kapil dev – (Asian Publisher)

3. Engineering Drawing by Basant Agarwal & C. M. Agarwal - (McGraw-hill)
4. A Textbook on Engineering Drawing by P. Kannaiah, K. L. Narayana, K. Venkata Reddy

Online Resources

1. [1.https://nptel.ac.in/courses](https://nptel.ac.in/courses)
2. [2. www.slideshare.net/shameem.mist/engineering-drawing](http://www.slideshare.net/shameem.mist/engineering-drawing)
3. [3.https://www.powershow.com/viewfl/76303a-](https://www.powershow.com/viewfl/76303a-)
4. OWI5M/Engineering_Drawing_powerpoint_ppt_presentation
5. [4.https://www.powershow.com/view0/91a2bf-](https://www.powershow.com/view0/91a2bf-)
6. N2Q2N/Basic_engineering_drawing_solved_question_powerpoint_ppt_presentation

Suggested Learning Outcomes

Upon completion of the subject, the student shall be able to

1.0 Understand the basic concepts of engineering drawing

- 1.1 State the importance of drawing as an engineering communication medium
- 1.2 State the necessity of B.I.S. Code of practice for Engineering Drawing.
- 1.3 Explain the linkages between Engineering drawing and other subjects of study in diploma course.

Use of Engineering Drawing Instruments

- 1.4 select the correct instruments and draw lines of different orientation.
- 1.5 Select the correct instruments and draw small and large Circles.
- 1.6 Select the correct instruments for measuring distances on the drawing.
- 1.7 Use correct grade of pencil for different types of lines, thickness and given function.
- 1.8 Select and use appropriate scales for a given application.
- 1.9 Identify different drawing sheet sizes as per I.S. and Standard Lay- outs.
- 1.10 Prepare Title block as per B.I.S. Specifications.

2.0 Write Free Hand Lettering and Numbers

- 2.1 Write titles using sloping lettering and numerals of 7mm, 10mm and 14mm height
- 2.2 Write titles using vertical lettering and numerals of 7mm, 10mm and 14mm height
- 2.3 Select suitable sizes of lettering for different layouts and applications
- 2.4 Practice the use of lettering stencils.

3.0 Understand Dimensioning Practice

- 3.1 Define “Dimensioning.
- 3.2 State the need of dimensioning of drawing according to accepted standard.
- 3.3 Identify notations of Dimensioning used in dimensioned drawing.

- 3.4 Identify the system of placement of dimensions in the given dimensioned drawing.
- 3.5 Dimension a given drawing using standard notations and desired system of dimensioning.
- 3.6 Dimensioning standard features applying necessary rules.
- 3.7 Arrange dimensions in a desired method given in a drawing.
- 3.8 Identify the departures if any made in the given dimensioned drawing with reference to SP-46-1988, and dimension the same correctly.

4.0 Apply Principles of Geometric Constructions

- 4.1 Divide a given line into desired number of equal parts internally.
- 4.2 Draw tangent lines and arcs.
- 4.3 Use General method to construct any polygon.
- 4.4 Explain the importance of conics.
- 4.5 Construct conics (ellipse, parabola and hyperbola) by general method.
- 4.6 Construct ellipse by concentric circles method.
- 4.7 Construct parabola by rectangle method.
- 4.8 Construct rectangular hyperbola from the given data.
- 4.9 Construct involute from the given data.
- 4.10 Construct cycloid and helix from the given data.
- 4.11 State the applications of the above constructions in engineering practice.

5.0 Apply Principles of Projection of points, lines and planes (06 Hours)

- 5.1 Visualize the objects
- 5.2 Explain the I-angle and III-angle projections
- 5.3 Practice the I-angle projections
- 5.4 Draw the projection of a point with respect to reference planes (HP&VP)
- 5.5 Draw the projections of straight lines with respect to two reference Planes (up to lines parallel to one plane and inclined to other plane)
- 5.6 Draw the projections of planes (up to planes perpendicular to one plane and inclined to other plane)

6.0 Apply principles of orthographic projection

- 6.1 Explain the principles of orthographic projection with simple sketches.
- 6.2 Draw the orthographic view of an object from its pictorial drawing.
- 6.3 Draw the minimum number of views needed to represent complete engineering component.

Course Outcomes (CO)

Upon successful completion of the course, the students will be able to

Course Outcome		Cognizant Level	Linked Program Objectives (PO)
CO1	Acquiring the knowledge about the importance of Engineering drawing and Drawing instruments usage.	R	1, 4, 7
CO2	Practicing free hand Lettering & Numbering in different styles.	R/U	1, 3, 4, 7
CO3	Acquiring the knowledge about different methods of dimensioning systems.	R/U	1,3, 4, 7
CO4	Appreciate the usage of engineering curves for tracing the paths and surface profile of the machine components such as gear profile from involute and cycloid., cooling towers from hyperbola, automobile headlights from ellipse and dish antenna from parabola etc.	R/U/A	1, 2, 3, 4, 7
CO5	Realize the concept of projection and attain visualization projection of points, Lines and Planes. The student will also be able to draw the views related to projection of Points, Lines and Planes.	R/U/A	1, 2, 3, 4,6, 7
CO6	Realize the concept of orthographic projections and student will be able to draw orthographic views of an object from its pictorial drawing.	R/U/A	1, 2, 3, 4, 7

CO-PO MATRIX:

CO	PO1	PO2	PO3	PO4	PO5	PO6	PO7
CO1	3	-	-	3	-	-	3
CO2	3	-	1	2	-	-	3
CO3	3	-	1	2	-	-	2
CO4	3	1	2	2	-	-	2
CO5	3	3	2	2	-	1	1
CO6	3	1	3	3	-	-	2

BOARD DIPLOMA EXAMINATION, (C-21)
DME – I SEMESTER
ME-106, MID SEMESTER - I EXAMINATION
BASIC ENGINEERING DRAWING

Time: 1 Hour]

[Total Marks: 20

PART-A

04x02=08

Instructions :

1. Answer **ALL** questions.
2. Each question carries **TWO** marks.

1. Write freehand the following, using single stroke vertical capital letters of height 12 mm.
‘NECESSITY IS THE MOTHER OF INVENTION’
2. Redraw the following figure in Uni-Directional system of dimensioning.

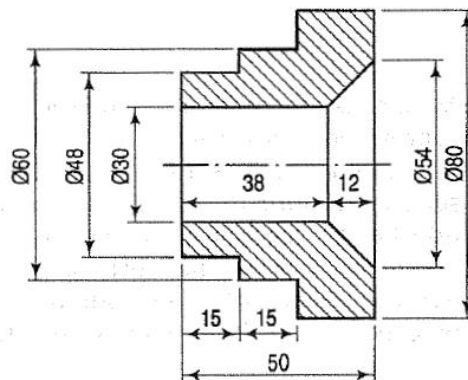

3. To divide a straight line of 70mm into 6 equal parts.
4. Bisect a given line AB of length 75mm.

PART-B

02x06=12

Instructions :

1. Answer **ALL** questions.
2. Each question carries **SIX** marks.

5. (a) Redraw the following figure with chain dimensioning.

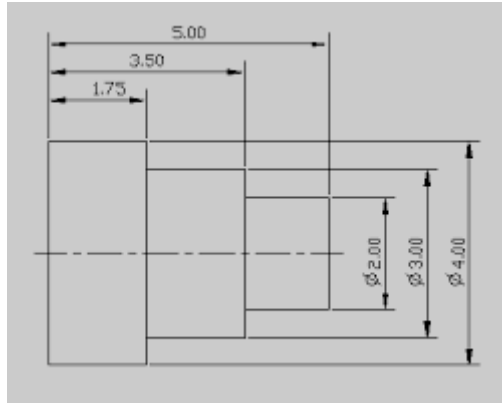

(Or)

5. (b) Redraw the following figure in aligned system of dimensioning.

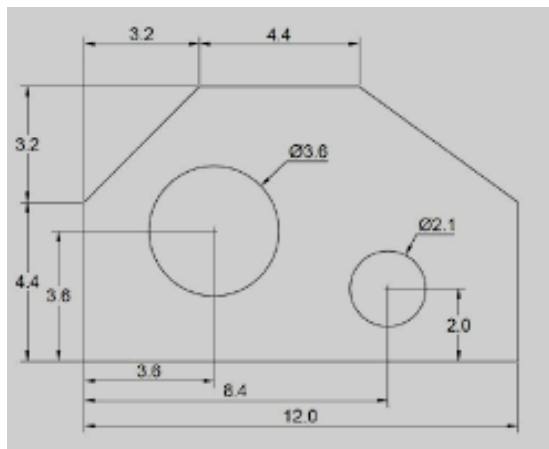

6. (a) Construct a regular pentagon of base side 30 mm in general method.

(Or)

6. (b) Draw an arc of radius 30 mm touching the given straight line AB of length 70 mm and passing through a point 'P' which is 55 mm above the line AB.

BOARD DIPLOMA EXAMINATION, (C-21)
DME – I SEMESTER
ME-106 MID SEMESTER - II EXAMINATION
BASIC ENGINEERING DRAWING

Time: 1 Hour]

[Total Marks: 20

PART-A

04x02=08

- Instructions :**
1. Answer **ALL** questions.
 2. Each question carries **TWO** marks.
1. Draw an arc of radius 30 mm touching the two given straight lines AB and AC making an angle 45° with each other.
 2. Draw an internal common tangent for the two given circles of equal radius of 30 mm if the centre distance is 75 mm.
 3. Draw the projections of a point A lying on both the planes.
 4. A line AB of length 70 mm is parallel to V.P. and inclined an angle of 30° to H.P. Draw its projections when its end A is on the H.P. and 20 mm in front of V.P.

PART-B

02x06=12

- Instructions :**
1. Answer **ALL** questions.
 2. Each question carries **SIX** marks.
5. (a) Construct an ellipse if the distance between focus and the directrix is 50 mm by eccentricity method. Also draw the normal and tangent at any point on the curve.

(Or)
 5. (b) Construct the locus of a point 'P' which is on the circumference of circle of radius 25 mm when it is rolling on a straight line for one complete revolution without slipping. Also name the curve.
 6. (a) Draw the projections of a line AB of length 75 mm parallel to HP and inclined at an angle of 30° to VP. The end A is 30 mm from both the reference planes.

(Or)
 6. (b) A square of base side 40 mm is perpendicular to both the reference planes. Draw its projections.

MODEL PAPER SEE
ME-106 BOARD DIPLOMA EXAMINATION, (C-21)
DME – I SEMESTER EXAMINATION
BASIC ENGINEERING DRAWING

Time: 2hours]

[Total Marks: 40

Important Note: Wherever any question has choice, marks will be allotted only to first attempted question. No marks will be allotted for extra questions answered.

PART-A

08x02=16

Instructions :

1. Answer **ALL** questions.
2. Each question carries **TWO** marks.
3. All the dimensions are in mm.
1. Write the following, using single stroke vertical capital letters of size 10 mm:
'DEVELOP AN ATTITUDE OF GRATITUDE'
2. Bisect the given angle of 55° .
3. Inscribe a pentagon in a given circle of radius 35 mm.
4. Draw the projections of a point 'P' lying on HP and 30 mm behind VP.
5. Draw the top view of a circular plane of diameter 50mm when its plane is perpendicular to HP.
6. Draw the projections of a cube of base side 30 mm when it is resting on one of its base on HP with one of its vertical face is parallel to VP.
7. Draw the front view of the block shown in figure

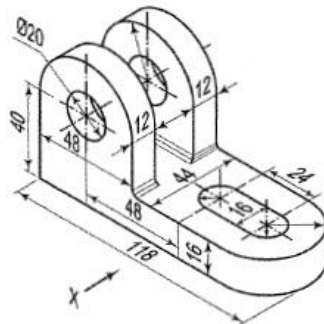

8. Draw the front view of the block shown in figure

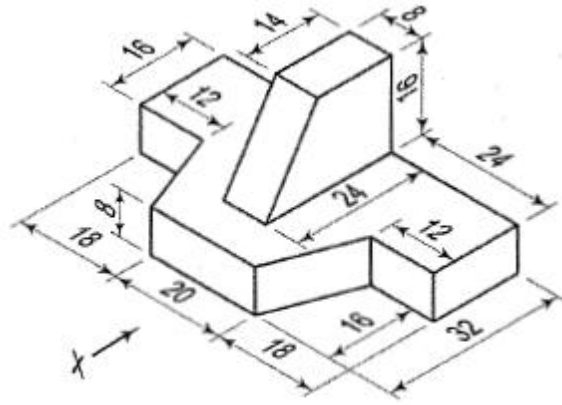

PART-B

04x06=24

- Instructions :**
1. Answer ALL questions.
 2. Each question carries **SIX** marks.
 3. All the dimensions are in mm.

9. (a) Redraw the following figure with aligned system of dimensioning.

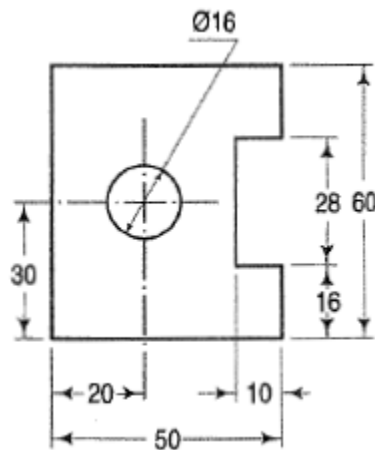

(Or)

9. (b) Inscribe a hexagon in a given circle of radius 30mm by keeping one of its side horizontal.

10. (a) Draw a parabola with the distance of the focus from the directrix at 50 mm using eccentricity method and draw a normal and tangent through a point 40 mm from the directrix.

(Or)

10. (b) A line AB 75 mm long is parallel to H.P. and inclined at 30° to V.P. The end A is 25 mm above H.P and 30 mm in front of V.P. Draw its projections.

11. (a) Draw the front view of the component shown in figure

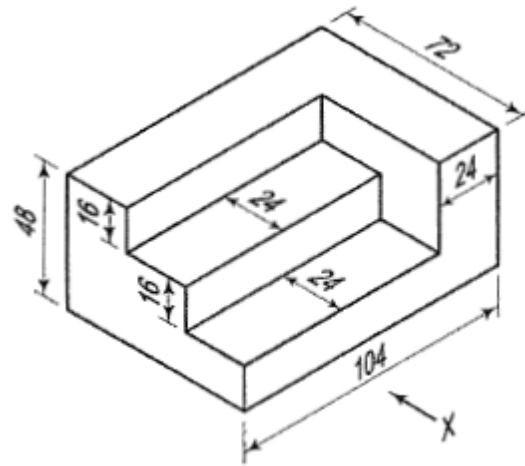

(Or)

11. (b) Draw the top view from the component as shown in figure.

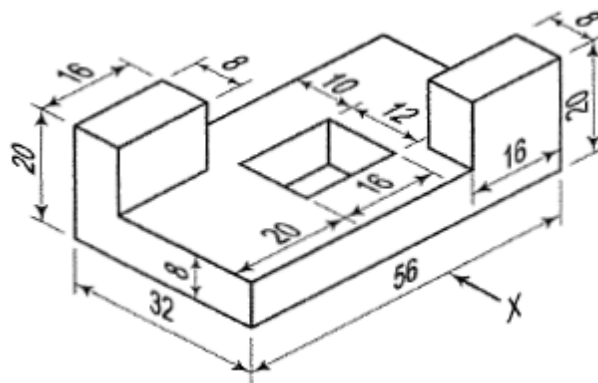

12. (a) Draw the frontview of component shown in figure

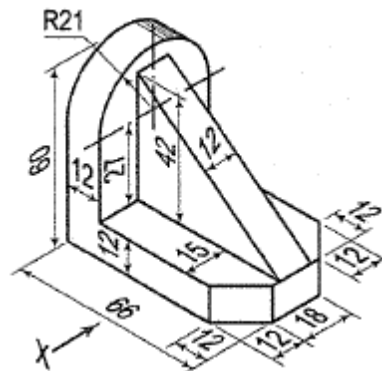

(Or)

12 (b) Draw the top view and front view of the component as shown in figure

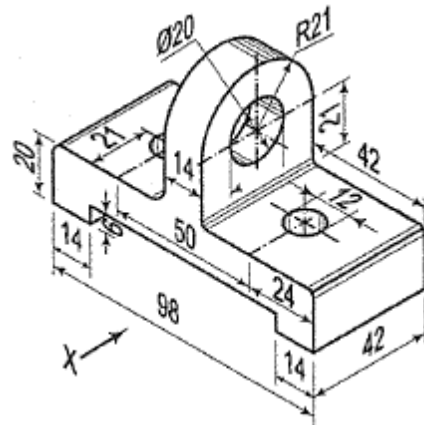

ME-107 - BASIC AUTOCAD LAB

Course Title :	Basic AutoCAD Lab	Course Code	ME-107
Semester	I	Course Group	Core
Teaching Scheme in periods (L:T:P)	1:0:2	Credits	1.5
Methodology	Lecture + Practice	Total Contact periods	45 Periods
CIE	60 Marks	SEE	40 Marks

Pre requisites:

This course requires the Basic Computer Skills and Practice concepts of engineering drawing

Course Outcomes

CO1	Importance and advantages of CAD. Set drawing area and draw geometric shapes and modify as per requirement
CO2	Creating new objects by using draw commands
CO3	Modifying the existing drawing using modify commands
CO4	Add dimensions and text with required font and size.
CO5	Generate isometric model and draw circle on three iso planes
CO6	Create 2D drawings with front, side view with all above features

Course Content

UNIT -1

Duration: 15 periods (T:5 + P:10)

1.1 The Computer Aided Drafting and its software

Definition of Computer Aided Drafting, the Advantages and importance of CAD software LIKE Auto CAD, Intelli Cad, ProG CAD etc., the features of Graphic Work station, CAD Environment: Screen, Various tool bars and menus.

1.2 Selection of commands

Commands using toolbars, menus, command bar. Repeating a command, Nesting a command and modifying a command. Use of prompt history window and scripts, mouse shortcuts. Creating the drawing. Opening existing and, saving of drawing, setting up a drawing. Setting and changing the grid and snapping alignment, and the Entity snaps.

1.3 Use of viewing tools of CAD & Use of coordinate systems of the drawing

Use of mouse, Scroll bar to move around within drawing, changing of magnification of drawing. Displaying of multiple views, the use of controlling visual elements like Line weight and line types.

Two dimensional coordinates such as Absolute, Cartesian, Relative Cartesian and Polar coordinates and direct method of drawing line.

1.4 Creating simple and complex entities

Drawing of lines, circles, arcs, ellipses, elliptical arcs, rays and infinite lines, rectangles, polygons,

1.5 Use the simple Modifying tools to modify the properties of entities

Entity selection and de selection methods, the Deletion of entities. Copying of entities within a drawing, between drawings, parallel copies,

UNIT -2

Duration: 15 periods (T:5 + 10P)

2.1 Use the Modifying tools to modify the properties of entities

Mirroring entities and arraying entities. The Rearranging of entities by Moving, Rotating and Reordering. The Resizing of entities by Stretching, Scaling, Extending, Trimming, and editing the length. The Braking and joining of entities. Chamfering and Filleting of entities

2.2 Creating complex entities

Drawing of shapes like rectangle, Polygon, polylines, Splines, donuts, and adding of hatch pattern

2.3 Use the drawing information retrieving tools Measure, Divide, Calculate and Display

Creating and editing of point entities. Dividing the entities in to segments. Calculation of areas of defined by points, closed entities, and combined entities, calculate the distance and angle between the entities. Displaying the information about the entities and drawing status.

2.4 Use the Text tool to create and formatting the various types of text Fonts and its styles

The creating, naming and modifying the text fonts, the Creation of line text, paragraph text, setting of line text style and its alignment. The Setting of Paragraph text style and its alignment, and modifying the text. Rectangular and polar array

2.5 Use Dimensioning concepts to create, Edit ,Control dimension styles & variables and Adding geometric tolerances

The creating of linear, Angular, Diametral, Radial, Ordinate dimensions. The creating leaders and annotations, making dimensions oblique, Editing the dimension text, controlling of dimension arrows and format. The Controlling of line settings and dimension text, the Controlling of dimension units, and dimension tolerance.

2.6 Isometric Views

Setting of isometric grid – change of iso planes, drawing straight line and circle
Create Isometric views of simple objects

.UNIT -3

Duration: 15 periods (T:3 + P:10)

Practise of 2D Drawings consisting of different line types, line weights, hatch, dimensioning and Text

Using appropriate commands creation of 2D drawings of standard components

Specific Learning Outcomes

UNIT-1

Duration: 15 periods (T:3 + P:10)

Upon completion of the course the student shall be able to Understand about the

1. Computer Aided Drafting and its software

- 1.1 Define Computer Aided Drafting
- 1.2 List the Advantages of CAD and also various CAD software's
- 1.3 Explain the importance of CAD software
- 1.4 Explain the features of Graphic Work station
- 1.5 Explain CAD Screen, Various tool bars and menus
- 1.6 Explain the benefits of Templates
- 1.7 Identify various CAD software's and their features

Use appropriate selection commands

- 1.8 Practice commands using toolbars, menus, command bar
- 1.9 Practice repeating a command, Nesting a command and modifying a command
- 1.10 Use prompt history window and scripts
- 1.11 Know the use of mouse for zooming and pan
- 1.12 Practice the Creating the drawing, saving the drawing with .drawing extension and Opening Existing drawing
- 1.13 Practice the setting up a drawing with drawing limits and drawing units.
- 1.14 Practice the setting and changing the ortho, grid and snapping alignment
- 1.15 Practice the Entity snaps

Use viewing tools of CAD & Use coordinate systems of the drawing

- 1.16 Practice the use of Scroll bar, pan command and rotating view to move around within drawing
- 1.17 Practice the changing of magnification of drawing

- 1.18 Practice how the coordinate system work and it is displayed
- 1.19 Practice the Two dimensional coordinates such as Absolute Cartesian, Relative Cartesian, Polar coordinates and direct method to draw a line.
- 1.20 Explain importance and use of Osnap/ Esnap points.
- 1.21 Practice to draw with other drawing commands like circle, polygon and other.

Create the simple and complex entities

- 1.22 Draw the lines, circles, arcs, ellipses, elliptical arcs, rays and infinite lines.

UNIT -2

Duration: 15 periods (T:3 + P:10)

2. Use the modifying tools to modify the properties of entities

- 2.1 Practice the various methods of entity selection like window, cross window, fence, last and previous methods and deselect ion method
- 2.2 Draw shapes like Rectangles, Polygons, Polylines, Splines, donuts
- 2.3 Practice the adding of hatch with required pattern and adjusting line angle and line space.
- 2.4 Practice the Deletion, breaking and trimming of entities
- 2.5 Practice the Copying of entities within a drawing, between drawings
- 2.6 Practice the Chamfering and Filleting of entities
- 2.7 Practice the making of parallel copies, Mirroring entities and Arraying entities
- 2.8 Practice the Rearranging of entities by Moving, Rotating and Reordering
- 2.9 Practice the Resizing of entities by Stretching, Scaling, and Extending.
- 2.10 Practice the Editing of polylines: Opening, Closing, Curving, Decurving, Joining, Changing width and editing vertices
- 2.11 Practice the Exploding of entities

Use the drawing information retrieving tools Measure, Divide, Calculate, Display, and Track

- 2.12 Divide the entities in to required number of segments
- 2.13 Calculate the areas defined by points, of closed entities, and combined entities
- 2.14 Calculate the distance between the entities
- 2.15 Calculate the angle between the entities
- 2.16 Display the information about the entities and drawing status
- 2.17 Track time spent working on a drawing

Use the Text tool to create and formatting the various types of text fonts and its styles

- 2.18 Practice the creating, naming and modifying the text fonts
- 2.19 Practice the Creation of line text, paragraph text
- 2.20 Practice the Setting of line text style and its alignment
- 2.21 Practice the Setting of Paragraph text style and its alignment

- 2.22 Practice the Changing of line text and Paragraph text
- 2.23 Practice the use of alternate text editor

Use Dimensioning concepts to create dimensions, Edit dimensions, Control dimension styles & variables and Adding geometric tolerances

- 2.24 Practice the creating of linear, Angular, Diametral, Radial, Ordinate dimensions
- 2.25 Practice the creating leaders and annotations
- 2.26 Practice the making dimensions oblique,
- 2.27 Edit the dimension text
- 2.28 Practice the Controlling of dimension properties like arrow types, size, dim line adjustment, dim offset, text size: primary and secondary units and format
- 2.29 Practice the Controlling of dimension units, and dimension tolerance

UNIT-3

Duration: 15 periods (T:3 + P:10)

3. Create 2D Drawings

- 3.1 Create 2D drawings of standard mechanical components with dimensions and text

Recommended Books

1. AutoCAD by George Omura
2. 4MCAD User Guide- IntelliCAD Technology Consortium

Key competence to be achieved by students / Suggested Learning Outcomes

S.No	Experiment Title	Key components
1	Introduction to CAD	<ul style="list-style-type: none"> • Open / close AutoCAD program • Understands AutoCAD Graphic User Interface(GUI) and various toolbars
2	Selecting commands & Working withdrawing	<ul style="list-style-type: none"> • Use prompt history window and scripts • Practice the setting up a drawing • Practice the Entity
3	a) Viewing drawing	<ul style="list-style-type: none"> • Use Scroll bar, pan command, and rotating view to move around within drawing • Control visual elements like Fill, Text, Blips and • Line weight
	b) Working with coordinates	<ul style="list-style-type: none"> • Use Two dimensional coordinates and Three dimensional coordinates • Use right-hand rule • Use filters in two and three dimensions • Define user coordinate system
4	Creating simple and complex	<ul style="list-style-type: none"> • Draw the simple shapes like lines, circles, arcs

	entities	<ul style="list-style-type: none"> and complex shapes like polygons, planes etc., Practice adding of hatch pattern
5	Getting Drawing information	<ul style="list-style-type: none"> Measure the intervals and distance between Entities. Divide the entities in to segments Calculate the areas defined by points, of closed entities, and Combined entities
6	Use the Text tool to create various types of text fonts and its styles	<ul style="list-style-type: none"> Calculate the areas defined by points, of closed entities, and Combined entities Use filters in two and three dimensions Draw the simple shapes like lines, circles, arcs and complex shapes like polygons, planes etc., Practice the adding of hatch pattern
7	Dimensioning drawing	<ul style="list-style-type: none"> Practice the Controlling of dimension properties like arrow types, size, dim line adjustment, dim offset, text size , primary and secondary units and format Practice the Controlling of dimension units, and dimension tolerance
8	Isometric Views	<ul style="list-style-type: none"> Use Iso snap command to create Isometric views
9	2D Drawings	<ul style="list-style-type: none"> Use proper 2D commands to create 2D drawings

Course Outcomes		CL	Linked PO	Teaching Hours
CO1	Importance and advantages of CAD. Set drawing area and draw geometric shapes and modify as per requirement	U/A	1,2,3,4,7	3
CO2	Creating new objects by using draw commands	U/A	1,2,3,4	12
CO3	Modifying the existing drawing using modify commands	U/A	1,2,3,7	6
CO4	Add dimensions and text with required font and size.	A	1,2,3,4	6
CO5	Generate isometric model and draw circle on three iso planes	U/A	1,2,3,4,7	3
CO6	Create 2D drawings with front, side view with all above features	A	1,2,3,4,7	15

MID SEM-I EXAM

S.No	Unit Name	R	A	Remarks
1	Unit-I	1, 2,3,4	5,6	
Total Questions		4	2	

MID SEM –II EXAM

S.No	Unit Name	R	A	Remarks
1	Unit-II	1, 2,3,4	5,6	
Total Questions		4	2	

SEMESTER END EXAM

S N	Unit name	Questions to be set for SEE		Remarks
		R, U	A	
1	Unit-1	1,2		
2	Unit-2	3,4		
3	Unit-3		5, 6	

CO-PO MAPPING MATRIX

CO	PO1	PO2	PO3	PO4	PO5	PO6	PO7
CO1	3	1	1	3	-	-	3
CO2	3	1	1	2	-	-	3
CO3	3	1	1	2	-	-	2
CO4	3	-	-	2	-	-	2
CO5	3	1	1	2	1	-	1
CO6	3	2	3	3	-	1	2

ME-107 - Basic AutoCAD Lab
MODEL PAPER FOR MID -1 (CIE)

TIME: 1hr

Marks: 20M

.....

PART-A

NOTE: Answer all questions
8marks

4 X 2 =

1. Draw a square of 50x50mm by using any CAD software.
2. Draw an equilateral triangle of 50mm side by using any CAD software.
3. Draw an ellipse with major axis 80mm and minor axis 30mm by using any CAD software.
4. Draw a line of 50mm and draw five parallel lines at 10mm distance by using offset command

PART-B

NOTE: Answer any one questions
12marks

1 X 12 =

5. Draw the following using any CAD software without dimensioning.

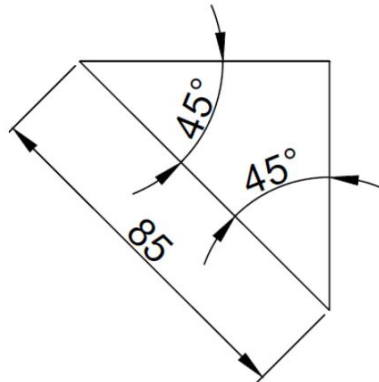

6. Draw the following using any CAD software without dimensioning.

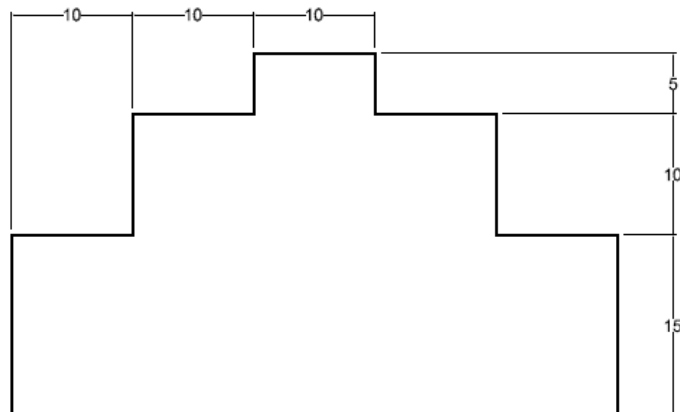

ME-107 - Basic AutoCAD Lab
MODEL PAPER FOR MID -2 (CIE)

TIME: 1hr

Marks: 20M

PART-A

NOTE: Answer all questions
8marks

4 X 2 =

1. Write text "CAD Lab" with Calibri font style and font size 10 by using any CAD software.
2. Draw a line of 10mm and divide it into four equal parts by modifying the point style to x shape.
3. Add continuous dimensions to divided line drawn in Q no. 2.
4. Draw a pentagon of side 60mm and calculate its area by using any CAD software.

PART-B

NOTE: Answer any one questions
12marks

1 X 2 =

5. Draw the following using any CAD software and add dimensioning.

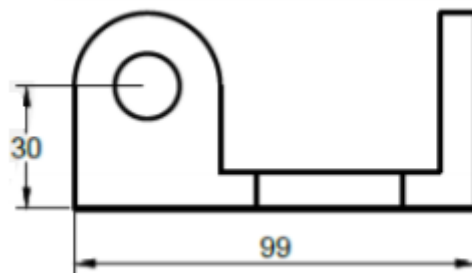

6. Draw the following using any CAD software and add dimensioning.

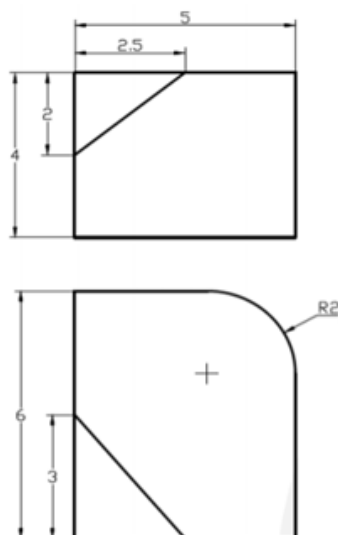

ME-107 - Basic AutoCAD Lab
MODEL PAPER FOR SEE

TIME: 2hr

Marks: 40M

PART-A

NOTE: Answer all questions
16marks

4 X 4 =

1. Draw the following fig by using any CAD software, change the line type and add dimensions. Also list the commands used in sequence.

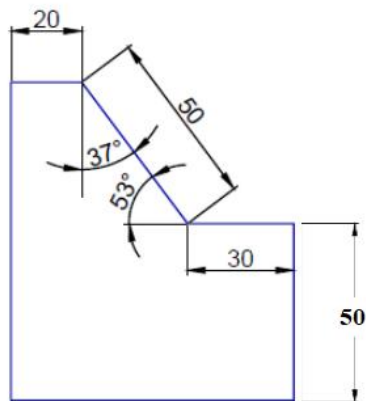

2. Draw the following arrow mark by using any CAD software, and add complete dimensions. Also list the commands used in sequence.

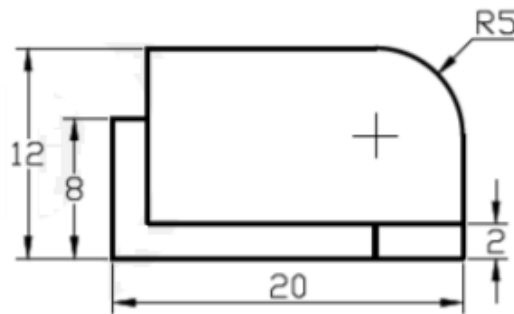

3. Redraw the following figure and add dimensions as shown in figure.

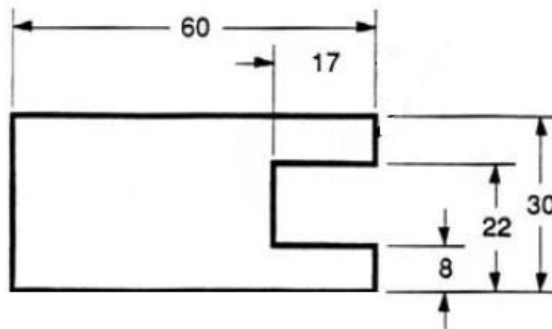

4. Draw isometric view of a cube of 100mm side by using any CAD software.

PART-B

NOTE: Answer any one questions

1 X 24 = 24marks

5. (a) Draw the following using any CAD software and add dimensioning. 15+5+4 marks
(b) List the commands in sequence and also write the procedure
(c) Add title box containing Student PIN, name and college name

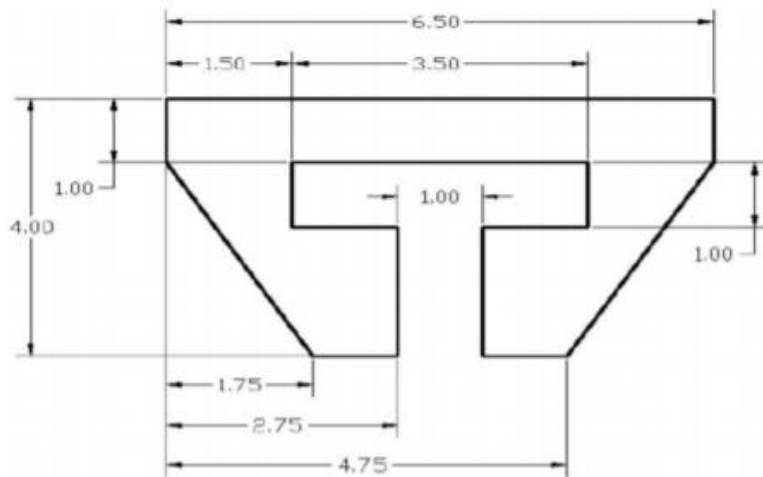

6. (a) Draw the following using any CAD software and add dimensioning. 15+5+4 marks
(b) List the commands in sequence and also write the procedure
(c) Add title box containing Student PIN, name and college name

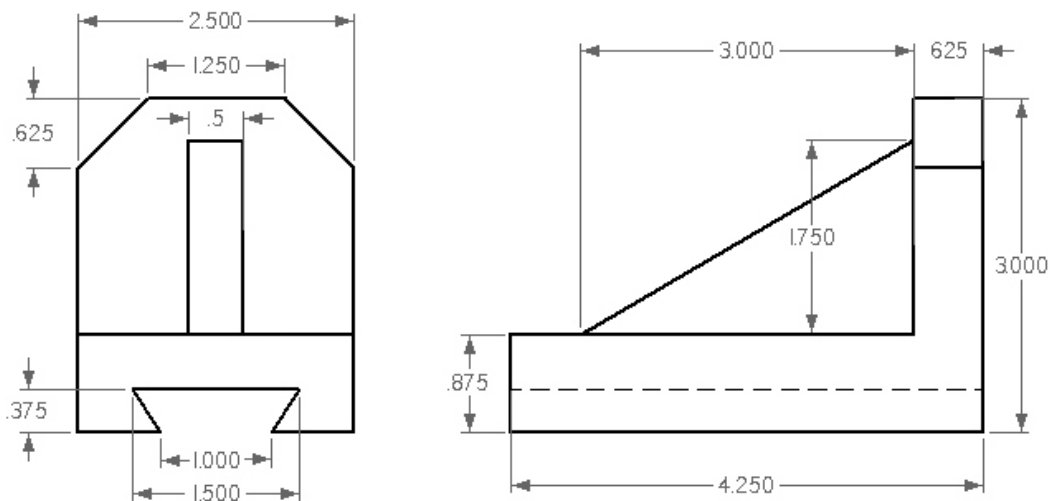

ME-108-BASIC WORKSHOP LAB

Course Title	Basic Workshop Lab	Course Code	ME-108
Semester	I	Course Group	Core
Teaching Scheme in Hrs (L: T: P)	1:0:2	Credits	1.5
Methodology	Lecture + Practice	Total Contact Hours :	45
CIE	60 Marks	SEE	40 Marks

Pre requisites

This course requires the basic skills of Handling Domestic tools; this course also requires the basic knowledge of basic mathematics at secondary school level.

Unit No	Unit name	Periods	Questions for SEE	Marks weightage	%of Weightage
			Handling/Manipulation/ Precision		
1	General Introduction & safety precautions	3		40	100
2	Fitting shop	12	1		
3	Forging shop	12	1		
4	Carpentry shop	9	1		
5	Sheet metal work	9	1		
	Total	45	4	40	100

Note: 1. At beginning of each trade Workshop Supdt/ Senior faculty should demonstrate all the tools and equipment available in that shop explaining its purpose/ application and also guide the students about safety precautions to be followed
 2. At the end of every practice class the object prepared by student should be evaluated for 20 marks before student pointing the mistakes committed by student.

1. Student can answer any one question out of 4 questions.
2. To pass in practical Exam student should acquire 50% marks in both CIE and SEE separately and CIE & SEE put together.
3. If the students acquire less than 50% in CIE, accordingly the students have to acquire more than 50% in SEE to get overall 50 % to pass

On completion of course the student should be able to

CO1	Know the importance of general safety precautions on different shop floors.
CO2	Understand the basics of removal of material from work piece surface to attain specific shape.
CO3	Ability to Identify and use the appropriate tools and equipment in Fitting Shop to perform fitting operations as per specified dimensions.
CO4	Ability to Identify and use the tools to perform forging operations and prepare simple shapes as per specification.

CO5	Ability to identify and use the tools to perform Carpentry operations and prepare simple wooden joints.
CO6	Ability to identify and use the tools to perform operations in sheet metal shop and prepare simple prototypes such as a rectangular open type tray and hollow cylinder.

COURSE CONTENTS

FITTING SHOP

1. Marking and Filing of 12/6 mm thick MS Flat to required size and Right angle.
2. Cutting with hack saw M.S. Flats of 6 mm thick and sawing.
3. Marking, cutting, drilling Practice

FORGING SHOP

1. Conversion of round to square.
2. Conversion of Square to Round
3. Conversion of round to Hexagon.

CARPENTRY SHOP

1. Cutting of wood with hand saw and planing practice.
2. Planing and Chiselling of wood.
3. Preparation of T Joint

SHEET METAL WORK

1. Practice on cutting of sheet with straight and curved snips
2. Formation of joints like grooved joints, locked groove joint
3. Preparation of a rectangular open type tray

REFERENCE BOOKS

1. Manufacturing Technology (Vol II) by P N Rao (McGraw Hill)
2. Principles of Foundry Technology by P L Jain (McGraw Hill)
3. Mechanical Workshop & Laboratory Manual By K. C. John

Competencies and Key competencies to be achieved by the student.

Title of the Job	Competencies	Key Competencies
Fitting shop		
1. Marking and Chipping on Mild steel flat of 12 mm thick	<ul style="list-style-type: none"> • Identify appropriate measuring tool • Handle appropriate marking tool • Mark the dimensions • Handle appropriate filing tool • Remove the material by filing from MS flats • File corner to exact right angles 	<ul style="list-style-type: none"> • Mark the dimensions • Remove the material by chipping from MS flats
2. Cutting with hack saw of MS flats of 6mm thick	<ul style="list-style-type: none"> • Check the raw material for size • Fix the work piece in vice • Mark the work as per given dimensions • Perform sawing • Load and unload hack saw blade from its frame • Use the hack saw to perform cutting operation 	<ul style="list-style-type: none"> • Load and unload hack saw blade from its frame • cut the work as per marked dimensions using Hack saw
3. Drilling on a MS flat of 2 mm thick	<ul style="list-style-type: none"> • Check the raw material for size • Apply the chalk on the surface and on all sides of the flat • Layout the dimensions and mark the lines using dot punch • Chamfer the edges through filing • Locate the hole centres using odd leg callipers and centre punching • Identify appropriate drill bit • Load and unload drill bit from the machine 	<ul style="list-style-type: none"> • Load and unload drill bit from the machine • Identify appropriate taps • Tap the hole

Title of the Job	Competencies	Key Competencies
Forging shop		
1. Conversion of Round to Square	<ul style="list-style-type: none"> • Identify the holding and striking tools • Heat the specimen to the appropriate temperature • Remove the specimen and hold it on the anvil • Hammer the specimen to the required shape 	<ul style="list-style-type: none"> • Heat the specimen to the appropriate temperature • Hammer the specimen to the required shape
2. Conversion of square to round	<ul style="list-style-type: none"> • Identify the holding and striking tools • Heat the specimen to the appropriate temperature • Remove the specimen and hold it on the anvil • Hammer the specimen to the required shape 	<ul style="list-style-type: none"> • Heat the specimen to the appropriate temperature • Hammer the specimen to the required shape
3. Conversion of Round to Hexagon	<ul style="list-style-type: none"> • Identify the holding and striking tools • Heat the specimen to the appropriate temperature • Remove the specimen and hold it on the anvil • Hammer the specimen to the required shape 	<ul style="list-style-type: none"> • Heat the specimen to the appropriate temperature • Hammer the specimen to the required shape

Title of the Job	Competencies	Key Competencies
Carpentry Shop		
1. Cutting of wood with hand saw	<ul style="list-style-type: none"> • Identify the orientation of grains and seasoning of wood • Select appropriate saw for cutting in each of the directions viz. across and along the grains • Select appropriate work holding device • Handle appropriate measuring and marking tools(Steel rule, Try square, Marking gauge) • Mark dimensions on work using Marking gauge • Fix the work in the vice • Perform cutting along the grains using Rip saw • Change the position of work in the vice • Perform cutting perpendicular the grains using cross cut saw 	<ul style="list-style-type: none"> • Identify the orientation of grains • Mark dimensions on work using marking gauge • Perform cutting along and perpendicular the grains using appropriate saw
2. Planning of wood	<ul style="list-style-type: none"> • Identify the direction for planing wood stock • Select appropriate jack plane • Prepare the jack plane for planing • (Load and unload the blade of a jack plane • Select appropriate work holding device • Perform marking on work using appropriate tool • Fix the work in the vice • Plane the surfaces on all four sides using jack plane 	<ul style="list-style-type: none"> • Identify the direction for planing wood stock • Prepare the jack plane for planing • Plane the surfaces on all four sides using jack plane
3. Chiselling of wood	<ul style="list-style-type: none"> • Select appropriate chisels and saw • Select appropriate work holding device • Select appropriate measuring and marking tools • Fix the work in the vice • Mark the position of grooves on work using marking gauge • Cut sides of grooves by hand saw • Chip the material using firmer chisel by applying pressure with mallet • Finish the grooves with rasp file 	<ul style="list-style-type: none"> • Select appropriate chisels and saw • Mark the position of grooves on work using marking gauge • Cut sides of grooves by hand saw • Chip the material using firmer chisel by applying pressure with mallet

<p>4. Preparation of a T joint</p>	<ul style="list-style-type: none"> • Select the appropriate cutting tools and work holding devices • Plane the wooden pieces on all sides • Mark to cut groove with try square • Cut the groove on one piece • Finish the groove • Assemble the two pieces to prepare T joint by using mallet 	<ul style="list-style-type: none"> • Trim the dovetail by chisel to exact size • Mark at an angle of 75° with bevel square • Cut the dovetail groove on second piece • Assemble the two pieces to prepare dovetail halving joint by using mallet
------------------------------------	---	--

Title of the Job	Competencies	Key Competency
Sheet metal Work		
<p>1. Practice on cutting of sheet</p>	<ul style="list-style-type: none"> • Cut the required sheet from the stock using snip • Mark the dimensions on the sheet using scribe & steel rule • Draw the circular shapes using divider • Perform rough cutting of the curved shapes using chisel and finish cutting using snips • Cut the straight edges using straight snips 	<ul style="list-style-type: none"> • Identify the marking and cutting tools • Cut the sheet of different shapes using appropriate tools
<p>2. Formation of joints like grooved joint, locked groove joint</p>	<ul style="list-style-type: none"> • Cut the sheet in to two halves • Form the flange on the sheet by folding the sheet along scribed lines using mallet & stakes • Perform bending edges of sheets applying moderate pressure using mallet • Inter lock the bent edges and apply pressure with mallet to make required joint 	<ul style="list-style-type: none"> • Identify the marking and cutting tools • Cut the sheet • Perform bending along the marked lines.
<p>3. Preparation of a rectangular open type tray</p>	<ul style="list-style-type: none"> • Draw the development of the object to be made • Place the pattern on the sheet • Mark the dimensions using scribe • Shear the required piece from the stock using straight snips • Mark the lines on the sheet to form bends • Strengthen the sides of sheet by single hem using hatchet stake • Form the sheet in to desired shape using stakes • Seam the corners by inserting laps of the adjacent sides with single hem 	<ul style="list-style-type: none"> • Drawing development of objects • Cut the sheet • Seam the corners by inserting laps of the adjacent sides with single hem

Course Outcome (CO)		Cognizant Level	Linked Program Outcomes (PO)	Teaching periods
CO1	Know the importance of general safety precautions on different shop floors.	R/U/A		1
CO2	Understand the basics of removal of material from work piece surface to attain specific shape.	R/U/A	1,2,3,7	
CO3	Ability to Identify and use the appropriate tools and equipment in Fitting Shop to perform fitting operations as per specified dimensions.	R/U/A	1,2,3,7	11
CO4	Ability to Identify and use the tools to perform forging operations and prepare simple shapes as per specification.	R/U/A	1,2,3,7	11
CO5	Ability to Identify and use the tools to perform Carpentry operations and prepare simple wooden joints.	R/U/A	1,2,3,7	11
CO6	Ability to Identify and use the tools to perform operations in sheet metal shop and prepare simple prototypes such as rectangular open type tray and hollow cylinder.	R/U/A	1,2,3,7	11
R: Remembering, U: Understanding, A: Applying				

Course Articulation Matrix

CO-PO Attainment Matrix:

COURSE OUTCOMES	PROGRAM OUTCOMES						
	PO1	PO2	PO3	PO4	PO5	PO6	PO7
CO1	3	2	2	-	-	-	1
CO2	3	2	3	-	-	-	1
CO3	3	2	3	-	-	-	1
CO4	3	3	3	-	-	-	1
CO5	3	2	3	-	-	-	1
CO6	3	3	3	-	-	-	1

Level 3- Highly Addressed, Level 2-Moderately Addressed, Level 1-Lowly Addressed.

ME-108 -BASIC WORKSHOP LAB
Mid Sem-I (CEE)

Time : 1 Hour

Total Marks : 20 M

Note: Answer any one question.

1. Mark and Prepare the square by filing as per the given figure.
2. Prepare the component by sawing as per the given figure.
3. Chamfer and drill the hole on work piece as per the given figure.
4. Prepare square section from the round bar as per the given figure.
5. Prepare hexagon section from the round bar as per the given figure.
6. Plane the wood as per the given figure.
7. Prepare grooves on wooden block as per the given figure
8. Prepare dovetail lap joint as per the given figure
9. Cut the sheet metal as per the given figure.
10. Prepare single seam joint as per the given figure.
11. Prepare double seam joint as per the given figure.
12. Prepare rectangular open tray as per the given figure.

Note: 1. For Mid sem 15 marks are to be awarded for conduct of experiment, 3 marks for record and 2 marks for Viva voice

2. Exam should be conducted from the trade in which student undergone training only as classes are conducted on rotation basis.

State Board of Technical Education, Telangana State

Model Paper
ME-108 -BASIC WORKSHOP LAB
Mid Sem-II (CEE)

Time : 1 Hour

Total Marks : 20 M

Note: Answer any one question.

1. Mark and Prepare the square by filing as per the given figure.
2. Prepare the component by sawing as per the given figure.
3. Chamfer and drill the hole on work piece as per the given figure.
4. Prepare square section from the round bar as per the given figure.
5. Prepare hexagon section from the round bar as per the given figure.
6. Plane the wood as per the given figure.
7. Prepare grooves on wooden block as per the given figure
8. Prepare dovetail lap joint as per the given figure
9. Cut the sheet metal as per the given figure.
10. Prepare single seam joint as per the given figure.
11. Prepare double seam joint as per the given figure.
12. Prepare rectangular open tray as per the given figure.

Note: 1. For Mid sem 15 marks are to be awarded for conduct of experiment, 3 marks for record

and 2 marks For Viva voice

2. Exam should be conducted from the trade in which student undergone training only as classes are conducted on rotation basis.

State Board of Technical Education, Telangana State
Model Paper
ME-108 -BASIC WORKSHOP LAB
(SEE)

Time : 3 Hours

Total Marks : 40 M

Note: Answer any one question.

1. Mark and Prepare the square by filing as per the given figure.
2. Prepare the component by sawing as per the given figure.
3. Chamfer and drill the hole on work piece as per the given figure.
4. Prepare square section from the round bar as per the given figure.
5. Prepare hexagon section from the round bar as per the given figure.
6. Plane the wood as per the given figure.
7. Prepare grooves on wooden block as per the given figure
8. Prepare dovetail lap joint as per the given figure
9. Cut the sheet metal as per the given figure.
10. Prepare single seam joint as per the given figure.
11. Prepare double seam joint as per the given figure.
12. Prepare rectangular open tray as per the given figure.

Note: marks are to be awarded for conduct of Experiment, writing of procedure, Record and viva voce

SC-109 - BASIC SCIENCE LAB

Course Title	Basic Science Lab	Course Code	SC-109
Semester	I	Course Group	Practical
Teaching Scheme in Pds/Hrs(L:T:P)	1:0:2	Credits	1.5
Type of course	Tutorial & Practical	Total Contact Periods	45
CIE	60 Marks	SEE	40 Marks

Physics Lab

Pre requisites: Knowledge of basic concepts of basic High school science and basic mathematics

Course objectives: To provide practical knowledge about the basics of Physics instrumentation and calculations/measurements.

Course Outcomes	
CO1	Understand Vernier caliper principle and calculate accurate measurement of lengths and volumes of various objects
CO2	Understand Screw Gauge principle and calculate accurate measurement of thickness of various thin objects
CO3	Understand vectors and resultant of vectors and verify Parallelogram law of forces and Triangle law of forces
CO4	Understand the concept of viscosity and calculate Coefficient of viscosity of a liquid by capillary method
CO5	Verify Boyle's law employing Quill tube.

CO	PO1	PO2	PO3	PO4	PO5	PO6	PO7
CO1	3			-	-	1	1
CO2	3			-	-	1	1
CO3	3			-	-	1	1
CO4	3			-	-	1	1
CO5	3			-	-	1	1
	3					1	1

Learning outcomes

On successful completion of the course, the student will have ability to:

1. Determine the volumes of objects like cylinder, sphere and piece of pipe.
2. Determine thickness /diameter of small objects like glass plate and wire.
3. Verify the parallelogram law and triangle law of forces.
4. Determine the viscosity of liquid using capillary method
5. Verify Boyle's law employing Quill tube.

Course Delivery:

The course will be delivered through lectures, class room interaction, group discussions, graded exercises, demonstration and practice.

Tutorial: 1Periodd /Experiment:

1. Introduction to Physics practical and its importance, safety precautions in maintenance of equipment in the laboratory.
2. Maintenance of apparatus and equipment.
3. Follow of Do's and Don'ts.
4. Maintenance of data in manual and record book.
5. Write the procedure of the experiment before the commencement of each experiment.
6. Strictly following of instructions given from time to time by the lecturer-in-charge.
7. Demonstration of each experiment by the lecturer in charge.

Conduction of experiments: 2 periods/Experiment.

Student must perform experiment individually under the supervision of the lecturer-in charge.

EXAMINATION & EXPERIMENTS		
S.NO	EXAMINATION	EXPERIMENTS
1	MIDSEM-I	EXPERIMENT NO 1 & 2
2	MIDSEM-II	EXPERIMENT NO 3 & 4
3	SEMESTER END EXAMINATION	EXPERIMENT NO 1,2,3,4 and 5

Scheme of Valuation of SEE		
S.No	Particulars	Marks
1.	Objective/Aim	01
2.	Apparatus/Equipment	02
3.	Observations	02
4.	Principle including formula	02
5.	Experiment (Tabular form, readings, etc)	05
6.	Calculation and Result	05
7.	Viva Voce	03
	Total	20

References:

1. Basic Applied Physics – R.K. Gaur
2. Laboratory manual for class XI and XII – NCERT

Chemistry Lab

Prerequisite:

Knowledge of basic concepts of chemistry of secondary education.

Course Objectives:

To provide practical knowledge about the basics of preparation of chemical solutions and volumetric analysis of chemical compounds.

Course Outcomes:

On successful completion of the course, the student will have ability to attain CO:

Course Outcome	
CO1	Prepare the standard solution.
CO2	Estimate the amount of the HCl in the given sample of solutions
CO3	Estimate the amount of the NaOH in the given sample of solutions.
CO4	Estimate the amount of the H ₂ SO ₄ in the given sample of solutions.
CO5	Determine the hardness of water in the given sample.

CO	PO1	PO2	PO3	PO4	PO5	PO6	PO7
CO1	3	-	-	1	-	1	1
CO2	3	-	-	-	-	1	1
CO3	3	-	-	-	-	1	1
CO4	3	-	-	-	-	1	1
CO5	3	-	-	-	2	1	1

Course Delivery:

The course will be delivered through lectures, classroom interaction, group discussion, demonstration and practicals.

Conduction of experiments: Lecture 1 period + Experiment 2 periods.

Student must conduct experiment individually under the supervision of the staff-in-charge.

Lecture and Demonstration: 1 Period

1. Introduction of chemistry practical and its importance, safety precautions in maintenance of cleanliness and orderliness of chemicals in the laboratory.
2. Maintenance of apparatus and equipment.
3. Follow of Do's and Don'ts.
4. Maintenance of data in record book.
5. Write the procedure of the experiment before the commencement of each experiment.
6. Strict following of instructions given from time to time by the staff-in-charge.
7. Demonstration of each experiment by the staff in charge.

Course Content

Volumetric Analysis: (22.5 Periods)

Volumetric Analysis by Titrimetric Method:-

Volumetric Analysis - Titration – Standard Solutions - Concentration of solutions - Indicators - Acid base indicators - Selection of indicators - Endpoint of titration- Neutralization.

List of experiments:

1. Preparation of 0.05M sodium carbonate solution.
2. Estimation of hydrochloric acid present in 250 ml of solution by using standard sodium carbonate solution.
3. Estimation of sodium hydroxide present in 250ml of solution by using standard hydrochloric acid solution.
4. Estimation of sulphuric acid present in 250ml of solution by using standard sodium hydroxide solution.
5. Determination of total hardness of water sample by 0.02N EDTA solution.

Specific Learning Outcomes

Upon completion of the course, the student will have ability to

1. Prepare standard sodium carbonate solution and dilute to desired concentration.
2. Estimate hydrochloric acid present given volume of solution by using standard sodium carbonate solution.
3. Estimate sodium hydroxide present in the given volume of solution by using standard hydrochloric acid solution.
4. Estimate sulphuric acid present in the given volume of solution by using standard sodium hydroxide solution.
5. Determine the total hardness of water sample by using 0.02N EDTA solution.

Reference Books:

1. Vogel's Inorganic Qualitative and Quantitative Analysis.
2. Practical chemistry by O.P.Pande & others.
3. Qualitative and quantitative analysis by Alex.

EXAMINATION & EXPERIMENTS		
S.NO	EXAMINATION	EXPERIMENTS
1	MIDSEM-I	Experiment No. 1 & 2
2	MIDSEM-II	Experiment No. 3 & 4
3	SEMESTER END EXAMINATION	Experiment No. 1,2,3,4 and 5

Scheme of Valuation for MID I & II and SEE		
Sl. No.	Particulars	Marks
1	Identification of apparatus/equipment/chemical compounds/tools/etc.	2
2	Writing Principle and Procedure	5
3	Experiment and Observations	6
4	Calculation and Results	4
5	Viva-voice	3
Total		20

BOARD DIPLOMA EXAMINATION, (C-21)
MIDSEM – I
FIRST SEMESTER EXAMINATION
SC-109 - BASIC SCIENCE LAB

TIME: 1 Hour

TOTAL MARKS: 20

- Instructions:** (1) Answer both PART-A AND PART-B on separate answer sheets.
- (2) Each question carries **TEN** marks.

PART-A (PHYSICS LAB)

Perform ONE experiment allotted by the examiner.

1 x 10 = 10

1. Find the volume of given sphere using Vernier caliper.
2. Find the volume of given cylinder using Vernier caliper.
3. Find the volume of given piece of pipe using Vernier caliper
4. Determine the thickness of given glass plate using Screw gauge.
5. Find the cross sectional area of given wire using Screw gauge.

PART-B (CHEMISTRY LAB)

Perform ONE experiment allotted by the examiner.

1 x 10 = 10

1. Prepare 250 ml of 0.05M sodium carbonate solution.
2. Estimate the amount of hydrochloric acid present in 500 ml of the given solution using 0.02M sodium carbonate solution.
3. Estimate the amount of hydrochloric acid present in 250 ml of the given solution using 0.05M sodium carbonate solution.

BOARD DIPLOMA EXAMINATION, (C-21)
MIDSEM – II
FIRST SEMESTER EXAMINATION
SC-109 - BASIC SCIENCE LAB

TIME: 1 Hour

TOTAL MARKS: 20

Instructions: (1) Answer both PART-A AND PART-B on separate answer sheets.

(2) Each question carries **TEN** marks.

PART-A (PHYSICS LAB)

Perform ONE experiment allotted by the examiner.

1 x 10 = 10

1. Verify parallelogram law of forces.
2. Verify triangle law of forces
3. Determine coefficient of viscosity of water using capillary method.

PART-B (CHEMISTRY LAB)

Perform ONE experiment allotted by the examiner.

1 x 10 = 10

1. Estimate the amount of NaOH present in 500 ml solution using 0.02M HCl solution
2. Find the Molarity and estimate the amount of Sulphuric acid present in 250 ml solution using 0.01M NaOH solution.

BOARD DIPLOMA EXAMINATION, (C-21)
SEMESTER END EXAMINATION
FIRST SEMESTER EXAMINATION
SC-109 - BASIC SCIENCE LAB

Time: 2 Hours]

[Total Marks: 40

Instructions: (1) Answer both PART-A AND PART-B on separate answer sheets.
(2) Each question carries **TWENTY** marks.

PART-A (PHYSICS LAB)

Perform ONE experiment allotted by the examiner.

1 x 20 = 20

1. Find the volume of given sphere using Vernier caliper.
2. Find the volume of given cylinder using Vernier caliper.
3. Find the volume of given piece of pipe using Vernier caliper
4. Determine the thickness of given glass plate using Screw gauge.
5. Find the cross sectional area of given wire using Screw gauge.
6. Verify parallelogram law of forces
7. Verify triangle law of forces.
8. Determine coefficient of viscosity of water using capillary method.
9. Verify Boyle's law using Quill tube.

PART-B (CHEMISTRY LAB)

Perform ONE experiment allotted by the examiner.

1 x 20 = 20

10. Prepare 250 ml of 0.05M sodium carbonate solution.
11. Estimate the amount of hydrochloric acid present in 500 ml of the given solution using 0.02M sodium carbonate solution.
12. Estimate the amount of hydrochloric acid present in 250 ml of the given solution using 0.05M sodium carbonate solution.
13. Find the Molarity and estimate the amount of NaOH present in 100 ml of the given solution using 0.01M HCl solution.
14. Estimate the amount of Sulphuric acid present in a litre of solution using 0.01M NaOH solution.
15. Determine the total hardness of the given water sample using 0.02N EDTA solution

CS-110 - Basic Computer Science Lab

Course Title	Basic Computer Science Lab	Course Code	CS-110
Semester	I	Course Group	Practical
Teaching Scheme in Periods (L:T:P)	1:0:2	Credits	1.5
Methodology	Lecture +Tutorial	Total Contact Periods	45
CIE	60 Marks	SEE	40 Marks

Pre-requisite: The students should have basic knowledge of and basic knowledge of using computer

COURSE OUTCOME

CO1	Creating and saving a document, Formatting of text in MS-WORD
CO2	Spell checking, Mail merging and Printing of Documents in MS-WORD
CO3	Creating and Saving a presentation, inserting text and pictures & Formatting the text and pictures, Slide transition and Animation effects in MS-POWER POINT
CO4	Building Worksheet & Charts In Ms-Excel and Printing Of Worksheet
CO5	Creating Database, Tables, Forms, Queries, Reports In Ms-Access

Course Contents

1. Unit-I: Creating, Saving a document, Formatting of text in MS-WORD

Duration: 5 hrs

- MS_WORD - Creating and saving a document, Formatting of text

2. Unit-II: Spell checking, Mail merging and Printing of Documents in MS-WORD MS Word

Duration: 10 hrs

- MS-WORD - Spell Checking - Mail merging - Printing of Documents

3. Unit-III: Creating and Saving a presentation in MS Powerpoint and Slide transition and Animation effects

Duration: 10 hrs

- MS-POWER POINT - Creating and saving a presentation - Inserting text and pictures - Formatting the text and pictures- MS-POWER POINT - Effects of slide transition - Animation effects - Slide show & views of slides

4. Unit-IV Building & Charts in MS-Excel and Printing Of Worksheet

Duration: 10 hrs

- Building Worksheets – Building Charts, Printing EXCEL Worksheet

5. Unit-V Creating Database, Tables, Queries, Forms ,Reports & Printing

Duration: 10 hrs

- Creating Table, Viewing(ACCESS) – Creating Forms – Creating Queries and Viewing Database
- Creating of ACCESS Reports – Printing of ACCESS Tables, Forms, Reports

Specific Learning Outcomes:

1.0 Practice Operation of MS-Word.

- 1.1 Demonstrate starting MS word.
- 1.2 Identify the word screen elements.
- 1.3 Identify the tool bars on the screen.
- 1.4 Demonstrate loading different tool bars for their functionality.
- 1.5 Identify the drop down menus of the main menu and their functionality.
- 1.6 Demonstrate creating a sample text.
- 1.7 Demonstrate text formatting.
- 1.8 Demonstrate page formatting.
- 1.9 Demonstrate selecting, deselecting the text from menu and Copying.
- 1.10 Demonstrate importing text from other packages.

2.0 Spell checking, Mail merging and Printing of Documents in MS-WORD

- 2.1 Demonstrate search and replace of text.
- 2.2 Demonstrate spell checking.
- 2.3 Demonstrate creating tables.
- 2.4 Demonstrate mail merging of documents.
- 2.5 Demonstrate printing documents, merge printing of documents.
- 2.6 Demonstrate word procedure for importing figures, charts from other installed software.

3.0 Practice operation of MS-Power Point and Slide transition and Animation effects.

- 3.1 Demonstrate starting MS Power Point.

- 3.2 Identify the opening screen elements.
- 3.3 Identify the tool bars in the opening screen.
- 3.4 Demonstrate the selection of the methods of creating a new presentation.
- 3.5 Identify the different Auto Layouts of a slide.
- 3.6 Demonstrate creating a new slide
- 3.7 Demonstrate inserting a new slide.
- 3.8 Demonstrate slide transition effects.
- 3.9 Demonstrate a slide show.
- 3.10 Demonstrate animation effects.
- 3.11 Demonstrate creating an organization chart.
- 3.12 Identify the different slide views.

4.0 Building Worksheets & Charts in MS-Excel

- 4.1 Start EXCEL from the start
- 4.2 Identify the various parts of the window.
- 4.3 Identify the tabs and groups in ribbon layout
- 4.4 Identify and customizing the quick access toolbar
- 4.5 Identify the office button and commands of the drop down menu.
- 4.6 Practice loading of the existing worksheet or create a new worksheet.
- 4.7 Practice entering into the worksheet.
- 4.8 Practice formatting the cells.
- 4.9 Practice formatting the texts in the cells.
- 4.10 Practice changing the height and width of the cells.
- 4.11 Practice freezing the rows, columns.
- 4.12 Practice splitting the screens.
- 4.13 Enter formulas into the cells.
- 4.14 Enter formulas with built in functions.
- 4.15 Create a range name for the cells for group operations.
- 4.16 Create graph for the data in the worksheet.

5.0 Creating Database, Tables, Queries and Forms

- 5.1 Practice loading Ms Access from the start menu.
- 5.2 Create a database table using Database Wizard.
- 5.3 Enter data into the table.
- 5.4 Edit data in the table.

- 5.5 View data from the database.
- 5.6 Design a query.
- 5.7 View data using the query.
- 5.8 Demonstrate creating Forms.
- 5.9 View the database through Forms.
- 5.10 Practice navigating through the database through Forms.
- 5.11 Practice creating Custom Form using Forms Wizard.
- 5.12 Practice creating Reports using the Report Wizard.
- 5.13 Practice printing the tables, forms and reports.

EXERCISES

1. Create and save a document using MS WORD.
2. Format the Text document.
3. Change the page set-up and Insert Header/Footer.
4. Spell checking in the document.
5. Print the document.
6. Create main document and data file for mail merging.
7. Print the document with mail merging.
8. Create a table in the document.
9. Add row, column to a table.
10. Create and save a new presentation using MS Power Point.
11. Choose Auto Layout for a new slide.
12. Inserting text and pictures into a blank slide.
13. Inserting new slides into the presentation.
14. Applying slide transition effects.
15. Demonstrate a slide show.
16. Set animation to text and pictures in a slide.
17. Set the sounds, order and timing for animation.
18. Create and save a new work book in Excel
19. Operating Mouse to selecting tabs, groups, cells, group of cells
20. Entering Data into Worksheet
21. Editing of Worksheet
22. Formatting the text in the cells
23. Formatting the numbers in the cells.

24. Changing the height and width of cells.
25. Freezing Titles, splitting screen
26. Enter formulae for calculation in the cells.
27. Copying the formula over a range of cells.
28. Inserting built-in functions in to the cells.
29. Create graphs for the data using Chart Wizard.
30. Practice Data Forms in Excel.
31. Printing of worksheet
32. Creating Tables using wizard in Access
33. Creating Tables using Design View in Access.
34. Entering Data into tables
35. Viewing the data in table.
36. Creating a new query using wizard.
37. Creating a new query using design view.
38. Viewing the data using a Select Query.
39. Updating the data in table using Update Query.
40. Linking two Tables on Relational Aspect.
41. Create forms using Form Wizard.
42. Create reports using Report Wizard.
43. Printing the tables, forms and reports

Suggested Student Activities

1. Student visits Library to refer to Manual for the specifications
2. Student inspects the available equipment in the Lab to identify the components
3. Visit nearby Industry to familiarize with fabrication techniques
4. Analyze the connections in the UPS available in the Institution facility
5. Quiz , Group discussion, Surprise test

RECOMMENDED BOOKS:

1. Teach yourself Office 2007 for Windows – Coray Sandler, Tom Badgett, Jan Weingarten, BPB Publications.
2. The ABC s of MS Office 2007– Guy Hard-Davis, BPB Publications.
3. Working in MS Office - Ran Mansfield, Tata McGraw Hill Publications.

Student E-Learning reference

1. <https://www.tutorialspoint.com/word/index.htm>
2. <https://www.tutorialspoint.com/powerpoint/index.htm>

CO / PO MAPPING MATRIX

	COURSE OUTCOME	CL	Linked PO	Teaching Hrs
CO1	Creating and saving a document, Formatting of text in MS-WORD	R/U/A	1,2,3,4,7	5
CO2	Spell checking, Mail merging and Printing of Documents in MS-WORD	R/U/A	1,2,3,4,7	10
CO3	Creating and Saving a presentation, inserting text and pictures & Formatting the text and pictures and Slide transition and Animation effects in MS-POWER POINT	R/U	1,2,3,4,7	10
C04	Building Worksheet & Charts In Ms-Excel and Printing Of Worksheet	R/U/A	1,2,3,4,7	10
C05	Creating Database, Tables, Forms, Queries, Reports In Ms-Access	R/U/A	1,2,3,4,7	10

MODEL PAPER OF **MID SEM- I** EXAM

TIME: 1 hr

MARKS: 20

ANSWER ANY ONE QUESTION. EACH QUESTION CARRIES TWENTY MARKS.

20 x 1 = 20

1. Demonstrate Starting MS word and identify the word screen elements.
2. Draw and explain the groups and commands in Home tab under ribbon in Ms word.
3. Demonstrate text formatting in Ms word.
4. Demonstrate procedure for checking of spelling and grammar using dictionaries.
5. Demonstrate paragraph formatting in Ms word.
6. Draw and explain the groups and commands in page layout tab under ribbon in Ms word.
7. Demonstrate page formatting in Ms word.
8. Demonstrate procedure for creating Mail merging process in Ms word.
9. Demonstrate creating of table and adding rows and columns to the existing table in Ms word.
10. Demonstrate finding and replacing of text & searching for a bookmark.
11. Demonstrate starting of MS Power Point and identify the opening screen elements.
12. Draw and explain the groups and commands in Home tab under ribbon in MS Power Point.
13. Demonstrate different Auto Layouts of a Slide in MS Power Point.
14. Demonstrate Slide Transition effects in Ms Power Point.
15. Demonstrate different Animation effects in Ms Power Point.
16. Draw and explain the groups and commands in Animations tab under ribbon in MS Power Point.
17. Demonstrate different Slide views in MS Power Point.
18. Draw and explain the groups and commands in Review tab under ribbon in MS Power Point.
19. Demonstrate inserting and formatting of text and pictures in MS Power Point.

MODEL PAPER OF **MID SEM- II EXAM**

TIME: 1 hr

MARKS: 20

ANSWER ANY ONE QUESTION. EACH QUESTION CARRIES TWENTY MARKS. 20
x 1 = 20

1. Write procedure to open Excel window and Draw and label the parts in Excel window.
2. Draw and Write about groups and commands under Formulas tab under the ribbon in MS-Excel.
3. Write procedure to format the text in the cells.
4. Write procedure to enter formulas with built in functions.
5. Write procedure for creating chart in MS-excel.
6. Write Procedure for formatting numbers in MS-Excel.
7. Write procedure for writing criteria and extract the data.
8. Write procedure for printing of a worksheet.
9. Write procedure for formatting of chart in Ms-excel.
10. Write procedure to jump to different workbooks & import worksheet from different workbook.
11. Write procedure to create a database.
12. Write procedure to create a table using design view.
13. Write procedure to create form using forms wizard.
14. Write procedure for creating reports using report wizard.
15. Write procedure for creating a Custom Form.
16. Write the procedure to create custom reports.
17. Write the procedure to print active sheet.
18. Write the procedure for Printing of reports.
19. Draw and explain the groups and commands in create tab under ribbon in Ms access.
20. Write the procedure for creating Filter by form.

MODEL PAPER OF END SEMESTER EXAM

TIME: 2hr

MARKS : 40

ANSWER ANY ONE QUESTION. EACH QUESTION CARRIES TWENTY MARKS.

20 x 1 = 20

1. Write procedure for Creating and saving a document and draw and label the different parts of opening screen elements in Ms word.
2. Draw and explain the groups and commands in Home tab under ribbon in MS Power Point.
3. Write procedure for applying sounds, order, timing and effects of animation in a presentation.
4. Write procedure for character formatting in Ms word.
5. Draw and explain the groups and commands in Home tab under ribbon in Ms word.
6. Write procedure for creating main document and data file for mail merging.
7. Write procedure for page formatting in Ms word.
8. Write procedure for checking spelling and grammar using dictionary in Ms word.
9. Write procedure for printing of document in Ms word.
10. Draw and explain the groups and commands in Animations tab under ribbon in MS Power Point.
11. Write procedure to open Excel window and Draw and label the parts in Excel window.
12. Draw and Write about groups and commands under Formulas tab under the ribbon in MS-Excel.
13. Write procedure to format the text in the cells.
14. Write procedure to enter formulas with built in functions.
15. Write procedure for creating chart in MS-excel.
16. Write Procedure for formatting numbers in MS-Excel.
17. Write procedure for writing criteria and extract the data.
18. Write procedure for printing of a worksheet.
19. Write procedure for formatting of chart in Ms-excel.

20. Write procedure to jump to different workbooks & import worksheet from different workbook.
21. Write procedure to create a database.
22. Write procedure to create a table using design view.
23. Write procedure to create form using forms wizard.
24. Write procedure for creating reports using report wizard.
25. Write procedure for creating a Custom Form.
26. Write the procedure to create custom reports.
27. Write the procedure to print active sheet.
28. Write the procedure for Printing of reports.
29. Draw and explain the groups and commands in create tab under ribbon in Ms access.
30. Write the procedure for creating Filter by form.

Record book :- 10 marks

Viva-voce:- 10 marks

CH-111-SKILL UPGRADATION

Course Title :	Skill Upgradation	Course Code:	CH-111
Semester:	I	Course Group:	Core
Teaching Scheme in Hrs:	08	Credits:	2.5
Methodology:	Seminar+ G.D+ Activity	Total Contact Periods:	120
CIE:	By Rubrics	SEE	Rubrics

Basic English – Skills Upgradation

TASK:

LEVEL 1: Collection of material for learning skills

LEVEL2: Analysis of the material

LEVEL 3: Practice the activities

LEVEL 4: Assessment of the skills acquired

Activity before the activities:

Collect the material useful for learning Listening, Speaking, Reading, Writing (LSRW skills), Grammar and Vocabulary.

- 1. Collect newspaper clippings, books, puzzles, pictures, audio and video programmes in English.*
- 2. Talk to your classmates, seniors, alumni, teachers, successful people in job interviews and celebrities.*
- 3. Visit libraries to gather information.*
- 4. Visit useful websites for acquiring language learning skills.*

Activities:

1. Collect / Go through the different kinds of dictionaries and find out the differences.
 - a) List out the English words which are originated from Telugu, Hindi, Sanskrit and other Indian languages.
 - b) Prepare a list of technical words related to your branch.
 - c) Prepare the list of Homonyms, Homophones. Heteronyms, Heterophones and Capitonyms.
2. Collect the vocabulary building games and activities. Practice them individually, in pairs and groups.
3. Learn different kinds of reading a text. Practice various kinds of reading material.

4. Find out the differences between reading aloud and silent reading. Identify the advantages and disadvantages of speed reading.
5. Conduct a survey on the need for English. Talk to your classmates or seniors and find out the difficulties while learning English.
6. Practice dialogues on
 - a) Feelings
 - b) Likes & dislikes
 - c) Requests
 - d) Obligations
 (Dramatize the dialogues)
7. Introduce yourself through a line up activity or inner and outer circle activity.
8. Introduce tenses:
 - a) Write the diary using present tense.
 - b) Write an anecdote in past tense.
 - c) Prepare the weather forecast for the next week in future tense.
9. Observe the picture / photo and describe the persons, places and things using the describing words and prepositions.
10. Role play: Interview a celebrity using 'wh' and 'yes/no' questions.
11. Identify what is there in the bag using 'yes/no' questions.
12. Arrange the jumbled sentences in an order to make a meaningful paragraph.
13. Write a paragraph on your goals.
14. Write a letter to God / a celebrity.
15. Collect the letters written by great leaders, celebrities and officers.

Note: The above activities are indicative. The teacher may assign any other activity relevant to the skills introduced in the semester.

COURSE OUTCOMES

No.	At the end of the course, the students will have the ability to:
101.1	Use a dictionary and acquire vocabulary for social interaction.
101.2	Comprehend, identify main ideas, make inferences, visualize, and answer questions. Analyze and evaluate the written material.
101.3	Speak and write grammatically correct sentences, communicate effectively, express

	their likes, dislikes, feelings, make requests, express obligations and introduce themselves.
101.4	Use verbs in the different tenses according to the situations. Use Voice to express an action clearly
101.5	Describe people and objects, ask questions, use prepositions and write grammatically correct sentences.
101.6	Convey ideas in the form of paragraphs and letters

CO-PO Matrix

CO	PO 1	PO 2	PO 3	PO 4	PO 5	PO 6	PO 7	Mapping POs
101.1	-	-	-	-	3		3	5,7
101.2	-	-	-	-	3	2	3	5,6,7
101.3	-	-	-	-	3	3	3	5,6,7
101.4	-	-	-	-	2	2	3	5,6,7
101.5	-	-	-	-	2	2	3	5,6,7
101.6		-	--	--	2		3	5,7

Method of evaluation of the student activities (Rubrics)

Model Rubric:

Sl. No	Sub activity	Performance			
		Excellent	Good	Satisfactory	Need improvement
1	Step-1	Data was collected from more than four sources.	Data was collected from three to four sources.	Data was collected from two sources.	Data was collected only one source.
2	Step-2	All the material and data required for the activity was accurately prepared based on the data collected independently.	Almost all the material and data required for the activity was accurately prepared based on the data collected independently.	The materials and data required for the activity were accurately prepared based on the data collected with the help of teacher.	The material and data required for the activity was inaccurately prepared .
3	Step-3	Procedures were outlined in a step-by-step fashion that could be followed by anyone & performed the activity effectively.	Procedures were outlined in a step-by-step fashion, require explanation & performed the activity effectively.	Procedures that outlined were complete with 1 or 2 gaps and require explanation & performed the activity normally.	Procedures that outlined were not sequential, & performed the activity in a poor way.
4	Step-4	Presented/ explained the information about the activity in logical, interesting sequence with attractive visuals or diagrams.	Presented/ explained the information about the activity in logical sequence with visuals or diagrams.	Presented/ explained the information about the activity in logical sequence with less visuals or diagrams.	Presented/ explained the information about the activity without sequence and visuals or

					diagrams.
5	Conclusion / Summary	Provided a detailed conclusion/ summary clearly based on the data and activity.	Provided a conclusion / summary clearly based on the data and activity.	Student provided a conclusion/ summary effectively.	less Conclusions / Summary was not relevant.

Note: Separate rubric may be prepared according to the activity.

STUDENT ASSESSMENT RUBRICS

Sl. No	PIN	CO1	CO2	CO3	CO4	CO5	CO6	CO7	CO8	CO9	CO10	CO11	CO12	AVERAGE

I SEMESTER

SKILL UPGRADATION IN - BASIC ENGINEERING MATHEMATICS

ACTIVITY ASSESSMENT Steps

1. Mathematical concepts
2. Procedure
3. Explanation
4. Working with others
5. Mathematical errors

ACTIVITIES

1. Prepare a presentation to explain Logarithms.
2. Prepare a list of articles purchased from a super market and arrange in a matrix form to Compute the total amount using matrix multiplication.
3. Prepare a presentation to resolve a Partial fraction into simpler fractions.
4. Prepare a presentation stating the applications of Trigonometry.
5. List the methods to solve system of equations using Matrices and Determinants. Describe their features.
6. Visit the library, refer books on Mathematics and collect the details related to 2 Mathematicians.
7. Prepare a presentation to solve a triangle ABC in different cases.

CO / PO - MAPPING OF ACTIVITIES

CO	PO1	PO2	PO3	PO4	PO5	PO6	PO7	PO8	PO9	PO10
CO1	3	2	2	1			1	2	2	3
CO2	3	2	2	1	1		1	2	2	3
CO3	3	2	2	1			1	2	2	3

CO4	3	2	2	1			1	2	2	3
CO5	3	2	2	1			1	2	2	3
CO6	3	2	2	1			1	2	2	3
CO7	3	2	2	1			1	2	2	3

SEMESTER – I

SKILL UPGRADATION – C21 BASIC PHYSICS

TASK

LEVEL 1: Concept, Ethical Data, Materials, Source (Library/internet/others)

LEVEL 2: Methodology/procedure

LEVEL 3: Analysis/experiment

LEVEL 4: Interpretation/inference/evaluation.

Bridge activity: - Visiting your college Library:

(A) Prepare a list of available reference books in Physics with details such as author, publisher, edition etc.

(B) Prepare a list of Physics/Science journals, magazines, monographs with details.

(C) Prepare a log book of your visits to college library with brief description.

Activities:-

1. Discover some physical equations and apply principle of homogeneity.
2. Visit your College Physics laboratory. Collect equal amounts (mass in gm) of water and mercury. Calculate the density of each in CGS units. Express them in SI system of units using dimensional analysis. Infer the result.
3. Identify the bodies which have rolling objects like wheels, ball bearings. Prepare a chart with drawings and explain the importance of rolling friction.
4. Identify the objects where you apply various methods of reducing friction. Make each method as a module to one individual. Integrate all modules and generate a chart with brief explanation by the use of drawings.
5. Take two vectors with varying angles of inclination. Find the resultant using triangle law of vector addition by drawing the vectors in each case on a graph paper. Draw the conclusions. Correlate the result using parallelogram law of vector addition.
6. Three forces F_1 , F_2 and F_3 are acting on a body with angles θ_1 , θ_2 , and θ_3 with the horizontal respectively. Calculate the resultant force acting on that body. Draw the diagram.
7. Survey the places where curved paths are banked. Take photographs and reconstruct on the chart. Prepare a report.
8. Verify Hooke's Law by performing experiment using weights, spring and ruler.
9. Explore the internet. Prepare a power point report on surface tension and wetting, viscosity.
10. Debate on Green house effect and global warming. Justify the advantage of green house effect. Prepare a video clip and power point report with diagrams.

11. Design a mini wind mill/solar cooker/biomass plant as an application of conversion of energy.
12. Construct a model thermometer having centigrade scale, Fahrenheit and absolute scale with the help of available simple objects. Formulate the method of development.

NOTE: The above activities are indicative. The teacher may assign any other activity relevant to the course based on resources available.

Course Outcomes (CO)		Linked Pos	Activity Hours
CO1	Apply principle of homogeneity	PO1, PO2	3
CO2	Convert unit from one system to other system using dimensions	PO1, PO2, PO3	3
CO3	Prepare a chart with drawings explaining the importance of friction	PO1, PO2, PO7	3
CO4	Prepare a chart on reducing friction	PO1, PO2, PO4, PO5, PO7	3
CO5	Triangle law of vector addition - graphical analysis – correlation with parallelogram law of vector addition	PO1, PO4,	3
CO6	Calculate resultant force by component method	PO1, PO2, PO4	3
CO7	Banking of roads – practical observations	PO1, PO2, PO5	3
CO8	Verify Hooke's law with simple materials	PO1, PO2, PO3, PO4	3
CO9	Power point report on surface tension and wetting, viscosity by exploring internet	PO1, PO2, PO7	3
CO10	Debate on Green house effect and global warming. Advantage of green house effect - justification. Prepare a video clip and power point report with diagrams.	PO5, PO6, PO7	3
CO11	Design a mini wind mill/solar cooker/biomass plant as an application of conversion of energy-working models.	PO5, PO6, PO7	3
CO12	Construct a model thermometer having centigrade scale and absolute scale. Formulate the development.	PO1, PO2, PO4	3

SC-104 - GENERAL ENGINEERING CHEMISTRY

Suggested Skill Upgradation Activities

Activity Assessment Steps:

Level-1: Concept, Data collection and summarization, Material etc

Level-2: Prepare Chart, explain the process, perform the experiment etc, and prepare a report etc

Level-3: Oral or power point presentation of the activity.

Level-4: Submission of report.

Activity – 1

Prepare a chart or model of different types of orbitals and electronic configuration.

Activity – 2

Prepare the models/ charts on ionic and covalent bonding.

Activity – 3

Prepare and study the physical properties of True Solution, Colloidal Solution, and Suspension.

Activity – 4

Study of the acidic, basic or neutral nature of water sample collected from various sources.

Activity – 5

Compare the renewable and non-renewable energy sources.

Activity – 6

Study and analysis of ecosystem (lake, pond etc) existing in your surroundings.

Activity – 7

Study of bio diversity in your surroundings.

Activity – 8

Study and report the importance of forest resources.

Activity – 9

Study and report the importance of osmosis and reverse osmosis.

Activity – 10

Explain the method of purification of drinking water adopted at your residence.

Activity – 11

Preparation of the models/ charts on the softening of water by different methods and comparison.

Activity – 12

Study of electrolytes and non-electrolytes

Note: Any other skill upgradation activity related to the course may be taken up.

Mapping of POs to Skill Upgradation Activities

S.No	Name of the activity	Linked POs
1	Prepare a chart or model of different types of orbitals and electronic configuration.	1, 6,7
2	Prepare the models/ charts on ionic and covalent bonding.	1, 6,7
3	Prepare and study of physical properties of True Solution, Colloidal Solution, and Suspension.	1,4, 6,7
4	Study of the acidic, basic or neutral nature of water sample collected from various sources.	1,4, 6,7
5	Compare the renewable and non renewable energy sources.	1, 5, 6,7
6	Study and analyze the ecosystem (lake, pond etc) existing in your surroundings	1, 5, 6,7
7	Study of bio diversity in your surroundings	1, 5, 6,7
8	Study and report the importance of forests resources.	1,5, 6,7
9	Study and report the importance of osmosis and reverse osmosis.	1, 6,7
10	Explain the method of purification of drinking water adopted at your residence.	1, 6,7
11	Preparation of the models/ charts on the softening of water by different methods and comparison.	1, 6,7
12	Study of electrolytes and non-electrolytes	1, 6,7

Method of evaluation of the student activities (Rubrics)

Model Rubrics

S. No	Sub activity	Performance Level (Score)			
		Excellent (4)	Good (3)	Satisfactory (2)	Need improvement (1)
1	Level-1 (Data and Material collection)	All materials and data required for the activity were accurately prepared based on the data collected independently	Almost all materials and data required for the activity were accurately prepared based on the data collected independently	The materials and data required for the activity were accurately prepared based on the data collected with the help of teacher.	The materials and data required for the activity were inaccurately prepared .
2	Level-2 (Chart, Model, Experiment or Study)	Procedures were outlined in a step-by-step fashion that could be followed by anyone & performed the activity effectively.	Procedures were outlined in a step-by-step fashion, require explanation & performed the activity effectively.	Procedures that outlined were complete with 1 or 2 gaps and require explanation & performed the activity normally	Procedures that outlined were not sequential, & performed the activity in a poor way
3	Level-3 (Oral or Power point presentation)	Presented/ explained the information about the activity in logical, interesting sequence with attractive visuals or diagrams.	Presented/ explained the information about the activity in logical sequence with visuals or diagrams.	Presented/ explained the information about the activity in logical sequence with less visuals or diagrams.	Presented/ explained the information about the activity without sequence and visuals or diagrams.
4	Level-4 (Submission of Report)	Provided a detailed conclusion/ summary clearly based on the data and activity	Provided a conclusion / summary clearly based on the data and activity	Provided a conclusion/ summary less effectively	Conclusions /summary was not relevant.

Note: The above rubrics are indicative. Separate rubrics may be prepared according to the activity. Minimum passing score is 2.5.